

ISSN 2080-7279
2010 Volume 02 Number 02

foundations **2** /2010
of management

INTERNATIONAL JOURNAL

fom



WARSAW UNIVERSITY OF TECHNOLOGY
FACULTY OF MANAGEMENT

Foundations of Management

Editor – in - Chief

Tadeusz KRUPA

Faculty of Management

Warsaw University of Technology, Poland

e-mail: T.Krupa@wz.pw.edu.pl

Frequency: Published four issues per year; two regular and two special issues prepared by invited editor(s)

Internet: The International Journal - Foundations of Management is currently available on-line at:

<http://www.wz.pw.edu.pl/s110/foundations-of-management>

<http://bcpw.bg.pw.edu.pl/dlibra>

Publishing and Editorial Office:

Faculty of Management, Warsaw University of Technology

ul. Narbutta 85, 02-524 Warszawa, Poland

email: T.Krupa@wz.pw.edu.pl

tel.: +48 22 849 94 43, 22 234 84 32

fax: +48 22 849 97 98

Technical Editors

Teresa Ostrowska, T.Ostrowska@wz.pw.edu.pl

Katarzyna Rostek, K.Rostek@wz.pw.edu.pl

Cover Project and Print

Warsaw University of Technology Publishing House

ul. Polna 50, 00-644 Warszawa

tel.: +48 22 234-70-83

fax: +48 22 234-70-60

ISSN 2080-7279

All Rights Reserved

Printed In Poland

No part of this journal may be reproduced in any form or by any electronic or mechanical means including information storage and retrieval systems, without permission in writing from the Publishing and Editorial Office

© Copyright by Faculty of Management, Warsaw University of Technology, Warszawa 2010

Ladies and Gentlemen,

Foundation of Management (FoM) journal was established at the Faculty of Management at Warsaw University of Technology in order to provide an international platform of thought and scientific concepts exchange in the field of managerial sciences.

This new publishing forum aims at the construction of synergic relations between the two parallel trends in managerial sciences: social and economical – originating from economic universities and academies and the engineering trend – originating in from factories and technical universities.

Three of the great representatives of the engineering trend in managerial sciences - American Frederic W. Taylor (1856-1915) – developer of high speed steel technology and the founder of the technical with physiological trend in scientific management, Frenchman Henri Fayol (1841-1925), the author of basics of management and the division and concentration of work as well as the Pole Karol Adamiecki (1866-1933) graduate of the Saint Petersburg Polytechnic University and the professor of Warsaw University of Technology, creator of the time-scale system elements scheduling theory and diagrammatic method as well as the basics of the division of work and specialization – have, on the break of the XIX and XX century, all created the universal foundations of the management sciences. Therefore the title of the Foundation of Management is the origin of the scientific and educational message of the journal that is aimed at young scientists and practitioners – graduates of technical and economic universities working in different parts of Europe and World.

The target of the establishers of the Foundation of Management journal is that it will gradually increase its influence over the subjects directly linked with the issues of manufacturing and servicing enterprises. Preferred topics concern mainly: organizational issues, informational and technological innovations, production development, financial, economical and quality issues, safety, knowledge and working environment – both in the internal understanding of the enterprise as well as its business environment.

Dear Readers, Authors and Friends of the Foundation of Management – our wish is the interdisciplinary perception and interpretation of economic phenomena that accompany the managers and enterprises in their daily work, in order to make them more efficient, safe and economic for suppliers and receivers of the products and services in the global world of technological innovation, domination of knowledge, changes of the value of money and constant market game between demand and supply, future and past.

We would like for the Foundation of Management to promote innovative scientific thought in the classical approach towards economic and engineering vision of the managerial sciences.

The Guardian of the journal's mission is its Programme Committee, which participants of which will adapt to current trends and as an answer to the changing economic and social challenges in the integrating Europe and World.

Tadeusz Krupa

CONTENTS

Artur GAŚIORKIEWICZ

VISIBILITY, USABILITY AND ACCESSIBILITY

OF POLISH E-COMMERCE WEBSITES FROM THE B2C SECTOR7

Andrzej KAMIŃSKI

COMPUTER INTEGRATED ENTERPRISE

IN THE MRP/ERP SOFTWARE IMPLEMENTATION25

Krzysztof MAJ, Tadeusz KRUPA

THE MANAGEMENT METHOD PREVENTING A CRISIS SITUATION

IN AN ELECTRICAL ENERGY UTILITY37

Justyna PATALAS-MALISZEWSKA, Tadeusz KRUPA

THE MULTICRITERIA SELECTION METHODOLOGY

OF THE DECISION SUPPORT SYSTEM51

Sylwester PIĘTA

IT SYSTEMS SECURITY MANAGEMENT IN MIGRATION PROCESS63

Lilianna WAŻNA, Tadeusz KRUPA

THE MULTICRITERIA ASSESSMENT METHODOLOGY

OF THE DECISION SUPPORT SYSTEM IMPLEMENTATION EFFECTIVENESS81

Janusz ZAWIŁA-NIEDŹWIECKI

BUSINESS CONTINUITY101

VISIBILITY, USABILITY AND ACCESSIBILITY OF POLISH E-COMMERCE WEBSITES FROM THE B2C SECTOR

Artur GAŚIORKIEWICZ

Faculty of Management

Warsaw University of Technology, 02-524 Warszawa, Poland

a.gasiorkiewicz@wz.pw.edu.pl

Abstract: In the time of rapid development of Internet technologies and changing competitive environment, one of the most significant ways of creation of the e-commerce endeavor value is the increase of the incoming traffic of the internet website and the level of its conversion into business goals. Undertaking activities form the scope of internet marketing and increase of the usability and accessibility of websites are supporting this cause. However, this issues being broadly described in the literature they still have limited applications in business practice. The article presents the most important factors influencing the scope and characteristics of internet traffic that depends on the internet website owners. Issues are illustrates with research of listed factors that were performed on selected e-commerce systems from the B2C sector in Poland.

Key words: e-commerce system, B2C sector, website, internet, visibility, “10 Usability Heuristics”, usability and accessibility of website.

1 Introduction

Internet marketing issues are widely described in international literature and, more often, in national literature. Usually these are elaborations that are basing on traditional marketing concepts and are trying to adapt them for the needs of the new functioning conditions and focus of the needs of global enterprises [1, 12]. Additionally, even though they have considerable focus on the issues of internet advertising, they tend to pay little attention to the function of the enterprise's websites. Nevertheless many enterprises use their websites as the basic marketing communication channel with the market and its significance is even more considerable for enterprises with high level of virtualization.

The role of websites as the basic tool of marketing communication with internet customers becomes more and more popular among the authors of IT publications. They tend to point out the nature of websites, especially in the B2C sector, as IT systems that have a wide group of recipients, emphasizing the need to adjust their functionality and interface to the needs and requirements of the user [4]. J. Nielsen is said to be the founder of scientific research on the usability of websites, who, together with R. Molich, elaborated set of rules for the computer system interface design in 1990 [10]. These issues were later developed, by Nielsen and his associates, on the basis of analysis of the most frequent user interface errors in computer systems [9, 10]. The result

of Nielsen's work was the publishing of “10 Usability Heuristics”, key rules of Human–Machine interaction, which were the foundation of further works on the usability of IT system interfaces, especially the internet websites.

Parallel to the issues of marketing and usability, the issues of website accessibility for the biggest possible number of users, regardless of their features or disabilities, as well as independent of the software and hardware they are using [13]. The concept of accessibility was introduced by the World Wide Web Consortium (W3C), which collects over 400 organizations, enterprises, government agencies and universities for all over the World, which deal with determination of writing and transferring of internet websites. Web Accessibility Initiative was created as part of the W3C and aimed at providing website access for people with alternative abilities but also people using particular equipment, connections and software to access internet at work.

In case of e-commerce B2C systems, described in this article, website internet marketing, usability and accessibility issues are extremely important. They have a direct influence on the number of website users and their willingness to purchase and indirect influence on the level of sales income.

2 Incoming website traffic in relation to business goals

Incoming website traffic can be described with two basic parameters. First one is the size of the traffic and the second one is conversion level to business goals¹. Size of incoming internet traffic can be determined with the following parameters:

- determination of scope of the website for particular population in given time,
- determination of number of website displays in given time,
- determination of the number of unique users that display the website in given time,
- determination of the main site and sub-sites display number in given time.

The simplest way is to calculate website displays – for example with the website² statistics systems – in particular period of time. Total number of displays of the main page corresponds to the number it was seen by the users, including different kinds of internet bots³. Some statistical systems are able to recognize the displays irrelevant from the business point of view and count only the ones realized by real website users⁴. However, such data, even though important for the website owner, is improper for the comparison of different websites. During each display, understood as continuous activity of the user at the website⁵, the user can browse through

many different pages. Moreover the same user can be responsible for repetitive visits during the researched period of time. Therefore, considerable number of displays of the website does not have to correspond to the reach of the website⁶. That is why the most common factor to evaluate the popularity of the website is the number of unique users⁷ in particular time or – as an indirect solution – the number of visits generated by them. The ratio of number of unique users in relation to the total number of users of given population determines the reach of particular website in this population.

Reach of the website determines the brand recognition in given population, from the perspective of selling websites. It usually corresponds to the sales volume but it is not a relation that can be described with a simple mathematical formula. Incoming website traffic, even though it is valuable in case of websites that are an element of e.g. product campaign, is not a goal itself for e-commerce systems. Its conversion level into business targets is significant (sales in this case). Traffic that does not generate sales becomes a liability in the long-term perspective for the e-commerce website owner. On the contrary, relatively small traffic, which eventually leads to the purchase, can significantly influence the income level and proper margin modeling also means profit for the enterprise.

Factors that influence the incoming traffic level can be defined on the basis of user requirements analysis, which can lead to better fulfillment of user expectations. This approach is presented in the Table 1.

Website incoming traffic can be divided into initial and returning. Incoming traffic originates from the activities of new users of the website and the returning traffic is generated by the users, who are using the website again in given time⁸.

¹ „Conversion” concept in marketing describes the reaching of an advertising campaign goal through performance of particular activities by one of the receivers from the target group. Conversion can have the form of product purchase, registration in cooperation program, participation in promotional competition etc. Conversion is the purchase of a product by the customer and the conversion level is defined as the number of visits that end with a purchase, in relation to incoming internet traffic for the e-commerce websites of B2C sector.

² Website statistical system is used to collect and analyze statistical data that concerns the website server incoming traffic. One of the most common statistical tools of such kind is the freeware Google Analytics.

³ Internet bots are programs that automatically scan the content of websites. They operate as part of browsing systems (commonly known as internet browsers), internet folders and other information gathering systems. Such programs check the websites on regular basis in order to index them or update collected information. Another kind of internet bots is the validators that check the websites according to their consistency with specific technical demands. One of the examples can be the W3C Markup Validation Service, which checks the validity of the website source code. It can be found at: <http://validator.w3.org/>.

⁴ That are not the internet bots.

⁵ It is usually assumed that clicking in a next page of the website earlier than after 15-30 minutes is treated as part of the same

website display (session). Exceeding this time means that further activity is treated as next visit of the same user.

⁶ Example illustrating this issue is the Megapanel PBI/Gemius research result from September 2008, which indicates that the highest number of visits - 9,811 billion – was reached in Poland by the nasza-klasa.pl, what corresponded to the first place. The fourth place was taken by the Google browser (little over 3 billion). However, Google websites have the biggest number of unique users (13,38 million), what corresponds to the reach of 85,87% of Polish internet users and nasza-klasa.pl website, with 8,25 million unique users has the 52,97% reach what places it at fourth place.

⁷ One of the calculation methods of unique website users from given population is presented by Gemius SA, which specializes in research on internet. The documents can be found at: audyt.gemius.pl/docs/2006_09_19_white_paper_real_users.doc.

⁸ Usually described on monthly basis.

Table 1. Ways of initiating and fulfilling the needs in the internet purchasing process
(source: self study)

User activities	Website owner activities	Effect
website resources browsing	formulation of internet visibility	user interest
entering the website	formulation of usability and accessibility of the website	willingness to use the website (felt by the user)
browsing through the website	formulation of pricing policy, optimization of website's usability	purchase willingness
adding products to cart	formulation of sales optimization policy	willingness to extend the shopping and finalize transaction
verification and finalization of the transaction	formulation of website's usability and accessibility	transaction
waiting for the package	usability formulation and high quality of post-sales support	satisfaction from the transaction

High ratio of the initial traffic with relation to the returning traffic, maintained for a longer period, can correspond to low loyalty of the website users, which signals the necessity to perform business or technical changes. Short-term increase of the ratio's value is usually the effect of intensive internet marketing campaigns, which result in the income of considerable number of new users in a short period of time. The volume of both the initial and returning traffic can be influenced by few user motivating factors that should be answered with relevant e-commerce activities, which model the basic business and technical features of the website.

The main motivation for the new user to enter the selling website is the search of particular product of interest in spotted offer. Opinion about the website, especially expressed by previous users⁹ and concerning the satisfaction from the service quality or feeling of added-value¹⁰, is also a crucial factor in the gathering of new users.

In case of returning traffic, website features and user satisfaction have greater meaning in user motivation to visit the website again. User of B2B sector e-commerce system motivating factors are presented in the Figure 1.

Increase of the traffic incoming to the website is performed mainly through the fulfillment increase of the user's needs and requirements, from the perspec-

tive of the website owner. The most important activity in this manner that leads to the increase of the initial traffic is reaching with the information about the website (offers, promotions etc.) and making the user form the focus group interested. It is also relevant in terms of returning traffic, even though in this case different reaching mechanisms are used (e.g. personalized "push" communication¹¹). All of these activities are located in the area of website internet visibility formulation. Apart from strictly business aspects, the assurance of the feeling of comfort during using of the website is equally important, for the size of returning traffic and the conversion level of the incoming traffic. Website usability and accessibility modeling activities are used to support this cause.

Website features that influence the incoming traffic of the e-commerce B2C website are presented in the Figure 2.

Deliberations above are signaling the importance of internet marketing issues (in the scope of visibility modeling) as well as usability and accessibility as the factors that influence the size of website incoming traffic. It is important to mention that in case of selling websites, the activity optimization can significantly increase the sales income.

⁹ Totality of opinions, on given endeavor or its website, published and visible in the internet – defined as „e-publicity”.

¹⁰ Should not be treated as the price level – user satisfaction can originate from high functionality and usability or interesting content of the website.

¹¹ „Permission marketing”, is the e-mailings and newsletters sent to the customers registered in the database, who accepted to receive commercial information.

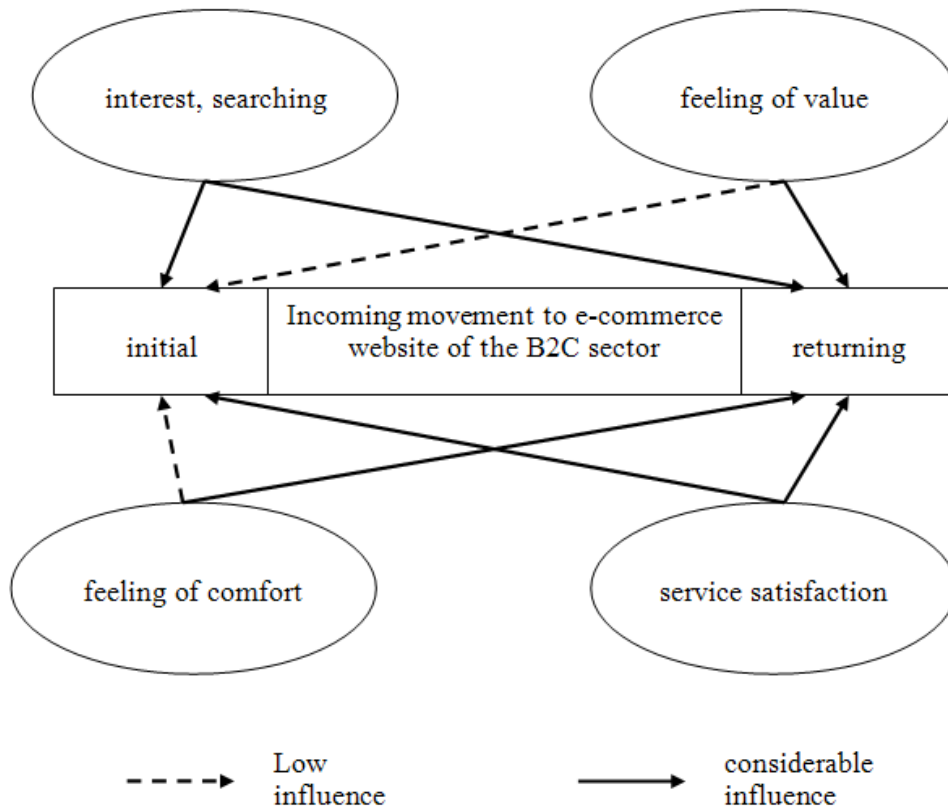

Figure 1. Factors motivating e-commerce system users in the B2C sector to visit the website
(source: self study)

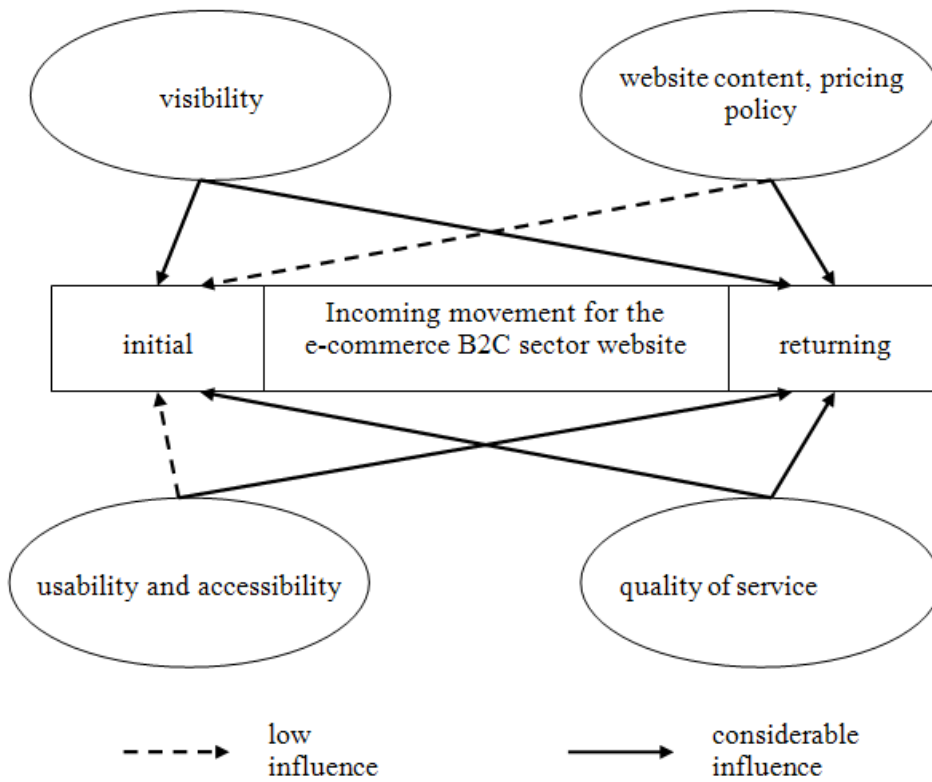

Figure 2. Features that influence the incoming traffic of the e-commerce B2C website
(source: self study)

One can use a simple example of the X enterprise to visualize this concept. With the assumption that the website of the X company notes 30 thousand visits per month, conversion level equals 2% and the average transaction level is 500 PLN – it is possible to calculate that the monthly sales income is approximately 300 000 PLN.

Table 2 presents the situation where the website optimization influences the sales volume of the X company, with the assumption of constant business conditions of the endeavor.

Table 2. Website optimization influence on the sales volume of the X company
(source: self study)

Monthly visits before the website optimization	30000
Monthly visits after the activities in the scope of internet marketing that led to the increase of the website visibility – increase of 50% ¹²	45000
Monthly visits after the realization of website accessibility activities – increase of 10% ¹³	49500
Conversion level after the realization of usability increase activities – increase of 100% ¹⁴	4%
Monthly sales increase after the website's optimization	990000
Change of monthly internet sales income from the X company after the optimization of the website	230%

Until recently the e-commerce industry treated the user registration as a form of validation of processed order and a tool that improved the loyalty of the customer and a convenience for the user during next purchases (due to the lack of need to input detailed data every time user is logged in). In described case the log-in form page was displayed to the user (if he was not al-

ready logged-in) when he had accepted the content of the basket and pressed the „Checkout” button.

Customer behavior analysis indicated that many potential users have undertaken repetitive unsuccessful trials to log-in. Some of them started the password recovery procedure, but only 25% of these users were the registered website users. The rest of the customers either started another registration procedure (it was revealed that approximately 45% of the customers have more than one account) or cancelled resigned form the purchase. One of the proposed solutions was the resignation from the obligatory registration, leaving it only as one of the suggested solutions for the user. Apart from the log0in form the “Continue” button was present, which allowed to perform the purchase without a registration in the website. This change led to the increase of order level by 45% and the annual sales increased by 300 million dollars. This example indicates the importance of the usability improvement activities for the e-commerce industry.

3 Website visibility

internet website visibility is defined as the easiness of finding of the website by a potential user with relation to particular needs. It is important to mention that the user usually is not searching for the website but finds in with encountered links. Therefore the visibility of the website is dependent on the easiness of remembrance of its location in the internet as well as the easiness and frequency of links, leading to the website, spotting by potential users.

All activities connected with the increase of websites visibility can be divided into natural (organic) and commercial (paid). Natural activities are undertaken by the internet users, which usually unwittingly influence the visibility of the website through pasting of the links in many different websites and providing its useful content to other users of the internet.

Commercial activities include all forms of internet advertising. It is basically the advertisements in internet browsers, which contribute to the half of on-line advertising spending in the USA and 30% in Poland¹⁵, internet „display”¹⁶ advertising and permission marketing, realized through e-mail.

¹⁵ see: Money.pl.

¹⁶ All forms of internet advertising connected with graphical creation – banners, layers in front of and behind the text, video advertisements etc.

¹² 50% website visit increase is usually assumed as a realistic target for the visibility optimization activities campaign for small and medium e-commerce websites. Business practice indicates that in many cases it is possible to exceed this value.

¹³ Estimation present in the literature speak of 3-20% visit increase as a result of accessibility optimization of the website and adjustment to the needs of people with sight disabilities (approximately 10% of the users), users with slower internet connections (about 25% of users), elderly, less experienced, slow learning users (around 15% of users).

¹⁴ Is the estimated average level of conversion increase as a result of website usability optimization according to the research of J. Nielsen, performed on the sample of 42 e-commerce websites (www.useit.com/alertbox/roi-first-study.html).

3.1 Positioning in web search engines

One of the most significant ways of improving the visibility of a website in the internet is the positioning¹⁷ in internet search engines. It results from two causes: firstly the internet search engines are a common source of knowledge for the internauts and secondly internauts while typing the search word are actually informing what they are looking for, what makes the internet advertising profiling much easier.

Usually the result of searching through particular phrase or expression through the web search engine provides two lists of results. First list consist of the natural results (also known as organic). In the assumption of web search engines creators, these results are neutral, based on the evaluation of the content and the natural popularity of the website, independent of the cooperation of business partners and web search engines. Second list, usually less exposed, consists of sponsored links, which are one of the forms of advertising in the internet.

Sometimes the sponsored links are also present at the first place of the natural results list, but are still highlighted as sponsored. In both cases the web search engine tries to present results, which best fit user's inquiry, but the list generating mechanisms are totally different. List of sponsored links is created on the basis of orders of advertisers, who pay in order for the link to be visible after typing one of the keywords into the search engine.

Algorithm that creates the natural results list is much more complex. Even though it is known mainly to the designers of the search engines, some guidelines and hints in the area of SEM (Search Engine Marketing) that allow to formulate general rules influencing the website positioning in the list of natural search results as a response to a typed keyword. Activities performed in order to get to the top of the result list are known as SEO (Search Engine Optimization). They consist of SO – Site Optimization and NP – Natural Placement [2].

Website optimization according to the search engines requirements is practically dependent on the site owner and his marketing and IT resources. It is based on the creation of valuable website content, according to both the users and search engine algorithms, and a number

of technical activities that favor the position in the search list.

It is, for example, correctness of the website's source code, clear headlines set marked with HTML tags, using internal text links, presence of keywords in the text in suitable proportions etc.

Natural positioning, according to the creators of searching algorithms, is a process directly independent of the website publisher, based on an automatic evaluation of suitability of the site on the basis of the number of links from other internet websites. Thus it is obvious that the valuable content and functionality, with simultaneous high usability, should significantly increase the position in the search results.

In practical functioning of SEO, with relation to commercial websites, it is more commonly positioned with paid service and there is a dispute in the internet industry about the ethics of natural positioning activities inspired by business activities.

Constant race of competitors to reach the first place in the search lists is, on one hand, contributing to the creation of great number of artificial creations in the internet (catalogues, positioning blogs, positioning devices), with little intellectual value, used only to manipulate the natural search results, on the other hand, creates many legal disputes, where legal institutions only tend to follow the market reality [8].

In order to explain the issue of dishonest natural positioning, one needs to relate to the way of publishing links. Every link published at websites consists of the destination address, object that is visually representing this object and other additional technical parameters.

For a common internet user as well as the majority of people responsible for the content of websites, it is natural to describe the links with a phrase that relates most accurately to the linked resources. Therefore if there will be a link to the Abecedex S.A. company present at the websites, than it will usually be described with the name of the company. If the link will lead to a particular spot of the website it is important, from the perspective of the author of the link, for the link to take a specific form e.g. Abecedex allegiance program.

¹⁷ Positioning in web search engines is the totality of activities leading to reaching a relatively high position of the website in the list of search results displayed in response to particular keyword.

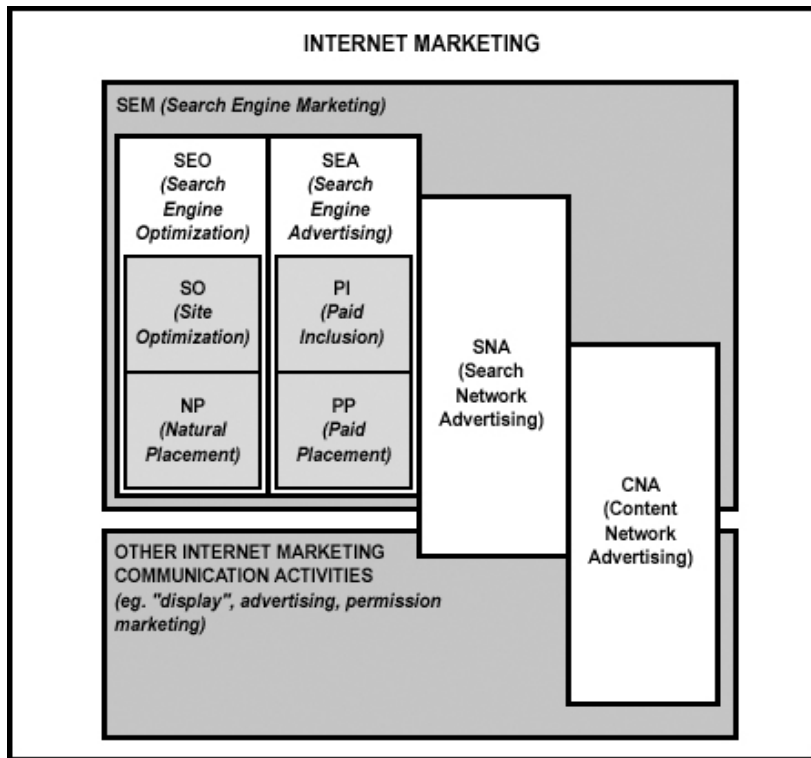

Figure 3. SEM partials in relation to the general internet marketing
(source: self study)

Majority of the "incoming" links, described with a suitable phrase have a significant meaning for the website. It is a determinant of popularity, which increases the chance to get an important position in the search list. Power of links is more important if, according to the search engine, the linking pages are more significant. Number and power of links influences the visibility of the website and indirectly also its business value.

However, this mechanism tends to be used unethically not only due to the financial inspiration of the natural (in theory) mutual linking process in the net. The problem emerges when website links present in other pages are described in a way different from the one that the owner of the linked website would prefer. If this situation is copied, than it contributes to positioning of the website according to improper keyword or phrase.

Effects of hostile positioning were described in Polish media many times, when insulting phrases typed into a search engine led to the websites of ministers or members of the parliament. This phenomenon is a perfect example of the search engine algorithm manipulation.

Much more organized form of internet advertising is the SEA – Search Engine Advertising. Scope of activi-

ties of SEA, contrary to SEO, is based directly on the commercial offer of search engines and creation of a financial liability towards them. There are two basic directions of such activities: PI (Paid Inclusion) – paid inclusion of the website into the search engine and PP (Paid Placement) – paid positioning of the links leading to the website in the list of search results appearing after typing of certain keywords. In Polish internet most search engines are based on the PP business model (e.g. Google, Onet.pl, WP.pl, Live.com).

The most common web search engine using the PI model is the Yahoo. In case of paid positioning there are two main types of account settlement used. The most obvious and common global system is the PPC model (pay per click), which charges according to the number of clicks. Another very popular model is the CPM (cost per mille), meaning charging according to the number of displays of the advertisement.

Paid positioning in the search results is currently one of the most effective advertising forms, due to the fact that the user is provided with the sponsored link as a response to a particular sought phrase. Positioning of the website according to properly defined phrases not only increases its visibility, but also positively influences the website incoming traffic conversion.

Common usage of web search engines in the modeling of website visibility is not random. According to different research on internet browsers, approximately 80 to 95% of the internet users use the search engines. In Poland this number is equal to 88% and the practical monopolist in this area is the Google, which services over 95% of inquiries of Polish internet users¹⁸. However, mere presence of the website in search results does not guarantee its visibility. The position of the link is equally important. Kevin Lee from American Did-it.com presented in 2005 interesting results of research performed by the consortium of three companies - Eyetools, Enquiro and Did it.com, concerning the perception of searching results by the internet users. The author performed analysis and determined these areas of search results pages, which were most commonly viewed by the users and identified the spots that were clicked by the internet users searching for desired information.

According to the presented research results, users pay special attention to the first three search results. These research results are viewed by almost 100% of users. Fourth result is spotted by 85% of the users and the sixth result is spotted by less than half of the users. The most attention grabbing sponsored link, placed as first at the standard Google layout (right column), draws the attention of over 50% of users but the fifth sponsored link draws attention of only 5% of the users. Other sponsored links are practically not visible and not spotted by the users. Internet users usually click on the first organic search results, including the highlighted sponsored link, placed as the first one – above the organic results. Clicking on the sponsored links in the right column usually concern only the first link.

Research results emphasize the meaning of natural search result meaning for the visibility of the company in the internet. On the other hand, poor popularity of links generated as a result of paid SEM does not undermine their business effectiveness. Payment for the sponsored links at the search result page of the search engine (SEA) is based on the PPC model. It is important to emphasize the bonus mechanism of the sponsored links in the Google browser with a relatively high CTR (Click Through Ratio). This ratio determines the percentage of advertisement displays that resulted in the click of the user. Reaching of 3,5% and over CTR ratio level gives the chance to display the results directly above the organic search.

Connection of SEA and SEO methods is the most effective in the SEM marketing, what was indicated by the practice. The main advantage of paid SEM is the possibility of getting immediate and reliable effects. It is extremely important in case of new endeavors. Sometimes it takes few months of waiting time before the page is indexed and the website position is built up in the natural search results page. However, natural positioning in the conditions of competitive rivalry and high popularity of keywords is not always as effective as the website owner expects.

3.2 Other methods of internet website visibility formulation

Relatively new, but efficient, method of visibility formulation in the internet is the use of the context advertising mechanisms. These mechanisms are listed as SEM tools mainly due to the fact, that the primary organizers of these systems are the leading web search engines. Modern context advertising market is rapidly developing and more and more companies provide such services. Their functioning is similar to the functioning of adserver systems¹⁹. Basic difference is the provision of an advertisement adequate to the content of the actual partner website content and not the specifics of the receiver group. Context advertisement systems are getting considerable popularity, due to the fact that they allow the cooperation for even the smallest advertisers and publishers²⁰, automatically directing the advertisements to suitable websites with the setting of accounts in PPC system.

In recent years the total internet advertisement spending budgets are decreasing for the classic and modern “display” type advertisements. However it does not mean the radical decrease of the role of these most aggressive, but also most creative, types of visibility formulation. They are remembered and recognizable by the internet users. It is important to mention that the most aggressive advertisements (pop-up, pop-under, top layer) are becoming less popular in favor of video advertisements and modern banner forms (billboard, skyscraper).

¹⁹ Systems, which have the publisher website advertisement emission, are controlled by the owner of the advertising company.

²⁰ In classical adserver systems the condition of website participation in the advertising network is the reaching of the level of 50-100 thousand visits per month. In case of context advertising systems, usually there are no limitations.

¹⁸ Gemius SA, „gemiusTraffic, 24.02.2009 – 02.03.2009” research.

Serious meaning in the creation of internet website visibility is also the effect of the permission marketing activities. They include all forms of commercial communication with the customer that is realized, after his approval, through electronic channels. The nature of this kind of advertising causes that it is mainly used to support the contact with the customer and periodically remind about the website and its content.

Summing up the deliberations about internet visibility it is important to mention that it dependent not only on the used forms of internet advertising. All other activities of the enterprise in the internet also contribute to this visibility that result in links popularization e.g. registration in branch catalogues, price comparison systems, virtual shopping malls, internet auctions etc.

4 Website usability

Usability is the measure of effectiveness and satisfaction brought with the product that is used to realize certain targets by particular users²¹. Little less formal but also very accurate definition is proposed by S. Krug, usability expert, which works for global brands like: Apple, Netscape, AOL and the author of a popular guide about website usability. He claims that usability is when “something is doing its job so that the person with medium (or even low) abilities and experience can use it according to the intentions of its creator and without the feeling of helplessness” [6]. This general definition proves that usability, with relation to websites, consists of many factors, among which the following are most popular:

- easiness to learn, the degree to which inexperienced users can perform easy tasks at the website,
- usage efficiency, the pace with which an advanced user realizes complex tasks with the system,
- easiness to remember, the degree to which the user who formerly have used the system can use it again without the necessity to learn,
- frequency and weight of errors,
- level of subjective user satisfaction²².

The list above indicates that the term “usability” should not be mistaken with, commonly used in IT terminology, “functionality”. Second one is used to name the totality of functions realized through the IT system. “Usability” is a more complex concept, which includes

IT issues and other like business, social, psychological, ergonomic etc.

Starting point for the usability designing and analysis should be the article by J. Nielsen “The 10 Usability Heuristics” mentioned in the beginning of the article (see Table 3).

Remaining consistent with the demands of usability of websites requires the performance of regular WWW research, both in the design phase as well as the implementation and exploitation. There are many usability researching methods, although some of them require special equipment.

Quite recently the “eyetracking”²³ method, which studies the user perception of particular website and identifies the areas that are beyond his sight scope, was very popular. Modern research is focusing on the user brainwave pattern analysis, which allows measuring the satisfaction level of the user. Despite of the direction of the usability science development directions, some of its rules remain unchanged. For example the research list, which are used at the particular stages of the website exploitation (see Table 4).

Part of the listed research requires considerable financial resources with relation to the project (usability issues usually consume 5-10% of new project’s budgets). However, it is crucial to remember that the simplest research, which allows seeing all the basic issues with the usability of the website, are affordable even for small enterprises, with limited investment budgets.

One of the basic research possible to conduct personally perform with a small group of users²⁴ is the, so called, Krug’s test. The research is based on displaying of a random website to the users and asking to provide answers for the following questions:

- what website is it?
- what page am I on?
- what are the main categories?
- what are the selection options at this level?
- where are we in relation to the website structure?
- how can I search for something?

Results coming from users’ answers allow identifying the most significant issues with website usability.

²¹ ISO 9241-11 norm.

²² <http://www.usability.gov/basics/whatusa.html>.

²³ Relating to internet website: research of user web pages perception, based on the eyeballs movement analysis.

²⁴ Suggested number is 3-5 users. Such methods, according to the author, are sufficient to determine 85% of current website issues.

Table 3. „The 10 Usability Heuristics” by J. Nielsen
(source: useit.com by J. Nielsen)

Heuristics	Explanation
Visibility of system status	The system should always keep users informed about what is going on, through appropriate feedback within reasonable time.
Match between system and the real world	The system should speak the users' language, with words, phrases and concepts familiar to the user, rather than system-oriented terms. Follow real-world conventions, making information appear in a natural and logical order.
User control and freedom	Users often choose system functions by mistake and will need a clearly marked "emergency exit" to leave the unwanted state without having to go through an extended dialogue. Support undo and redo.
Consistency and standards	Users should not have to wonder whether different words, situations, or actions mean the same thing. Follow platform conventions.
Error prevention	Even better than good error messages is a careful design which prevents a problem from occurring in the first place. Either eliminate error-prone conditions or check for them and present users with a confirmation option before they commit to the action.
Recognition rather than recall	Minimize the user's memory load by making objects, actions, and options visible. The user should not have to remember information from one part of the dialogue to another. Instructions for use of the system should be visible or easily retrievable whenever appropriate.
Flexibility and efficiency of use	Accelerators - unseen by the novice user - may often speed up the interaction for the expert user such that the system can cater to both inexperienced and experienced users. Allow users to tailor frequent actions.
Aesthetic and minimalist design	Dialogues should not contain information which is irrelevant or rarely needed. Every extra unit of information in a dialogue competes with the relevant units of information and diminishes their relative visibility.
Help users recognize, diagnose, and recover from errors	Error messages should be expressed in plain language (no codes), precisely indicate the problem, and constructively suggest a solution.
Help and documentation	Even though it is better if the system can be used without documentation, it may be necessary to provide help and documentation. Any such information should be easy to search, focused on the user's task, list concrete steps to be carried out, and not be too large.

Other very popular type of research is the user tests, which are based on performance of a particular website usage scenario. However, such research requires the help of an expert, who will objectively, on the basis of knowledge, experience and possible focus group research, determine the proper test scenario. This research will brutally reveal all the shortcomings of the system, which hidden from the website owner, usually contribute to the resignation of the user from the services of particular website.

Currently there is plenty of high quality foreign literature that deals with website usability. The creation and

development of the Web 2.0 idea, concerning website usability, contributed to the existence of such literature. Website design with high usability level is realized with the use of UCD (User Centered Design) methodology, which eliminates the possibly huge number of issues connected with website implementation.

Owners of commercial websites still underestimate are taking the usability issues. They think that finding the solution and acceptance are strictly on the side of the user. However, in highly competitive environment that is created by the internet, users do not hesitate to find alternative solutions, which are better in fulfillment

of their needs. It is important to emphasize that website usability increase gives the chance to improve the impact of internet activities.

Table 4. List of research used to model website usability

Stage	Research
Analysis	brainstorm, questionnaire (quantitative research), qualitative research (user interviews), focused group interview, competition analysis, case studies, personas ²⁵ .
Designing	prototyping, card sorting ²⁶ , requirements analysis (e.g. legal, functional).
Implementation	A/B tests, heuristic analysis, user tests.
Exploitation	questionnaire (quantitative research), qualitative research (user interviews), user tests, eyetracking, clicktracking, web-mining ²⁷ , requirements analysis (e.g. legal, functional, accessibility).

According to J. Nielsen’s research²⁸, usability can lead even to 100% of sales increase, 150% of incoming traffic increase (measured by the number of displays) and also improvement of many other business parameters of the website.

5 Website accessibility

World Wide Web Consortium (W3C)²⁹ defines the accessibility of the website as the degree to which it can be perceived, understood and browsed by all users, independent of their characteristics of disabilities as well as the features of software and hardware used by them.

²⁵ Research based on the creation of focus group user archetypes in order to better understand their needs.

²⁶ The method of grouping, naming and information relevance hierarchy creation, with the use of the focus group.

²⁷ Data mining domain adjusted to data specifics originated from websites and their statistics systems, considering e-commerce analytical needs. It is used for e.g. searching of characteristic user website exploring patterns, link suggestions according to revealed focus group, presentation of suitable advertising banners, estimation of purchase probability etc.

²⁸ <http://www.useit.com/alertbox/roi-first-study.html>.

²⁹ <http://www.w3.org/WAI/intro/accessibility.php>.

The effect of W3C activities, in the scope of network accessibility, is for example the elaboration of international internet content accessibility guide called „Web Content Accessibility Guidelines 2.0”. Its major part was adopted in the EU directive eEurope2002, on the basis of which all organizational units of EU countries are obliged to provide access to their websites without the discrimination of the users. United States issued the Rehabilitation Act, with the Section 508 obliges public institutions to providing the access to their informational websites electronic services.

Accessibility elements are also included in several norms concerning internet website design e.g. PKN-CEN/CWA 15554:2007(U).

In national economical practice the issue of website accessibility is usually omitted, usually due to budget limitations for the realization of internet projects and limited knowledge about W3C initiatives.

It is important to emphasize that website accessibility is not only the possibility of usage for people with alternative abilities and disabilities, but also:

- reaching and finding bigger group of receivers (including elderly people),
- reaching demanding users, which use modern mobile platforms or modern software,
- gaining better positions in web search engines (websites with higher accessibility are positioned higher by the searching bots),
- creation of the positive image of the enterprise³⁰.

6 Examples of V-U-A research

The example of practical application of presented deliberations is the performance of the visibility, usability and accessibility study of three shop websites with domestic appliances by the author, selected from ten of the biggest of such websites in Poland. The V-U-A research method was used in this elaboration (Visibility – Usability – Accessibility). Partial research areas in used methodology are collected in the table 5.

The following websites were subjected to the research:

- Agito.pl (<http://www.agito.pl>),
- Neo24.pl (<http://www.neo24.pl>),
- Electro.pl (<http://www.electro.pl>).

³⁰ www.energa.pl/accessibility/dlaczego_dostepnosc.xml.

Table 5. V-U-A research criteria

V-U-A research			
Research area / sub-area	Evaluation scale	Partial weight	Area weight
Visibility study	0-6	-	0,4
visibility in Google.pl	0-6	0,5	
website reach	0-6	0,3	
visibility and e-PR of the websites in selected related e-commerce websites	0-6	0,2	
Usability study	0-6	-	0,4
usability study based on the scenario of the website usage	0-6	0,5	
expert usability analysis	0-6	0,5	
Accessibility study	0-6	-	0,2
accessibility study at the level 1 of WCAG W3C with Cynthia validator	0-6	0,6	
research on the main improvements triad in the scope of accessibility – expert analysis	0-6	0,4	

6.1 Visibility study

Visibility study consists of three basic partial studies. First one concerns the visibility of researched websites in the Google.pl web search engine according to selected tags and phrases. The intention behind the selection of Google search engine is its high popularity in the internet (services approximately 95% of internet search engines enquiries in Poland) and high meaning for the websites indexed in it. Second partial study concerns the size and changes of the website reach during three months before the research was started. Third study dealt with visibility and opinions (e-PR) of the websites in selected Polish e-commerce websites.

Website visibility study in the Google.pl

Website visibility study in Google.pl search engine was performed in two steps. First one, based on qualitative research on 11 person group of test users, established the list of the most common search phrases, which would be used to perform the potential purchase of:

- dishwasher,
- LCD TV set.

Initial study indicated that users from the test group would use the following phrases and keywords:

- „AGD – domestic appliances”, „dishwashers”,
- „RTV”, „LCD TV set”.

Further part of the research included searching of the websites with the use of determined phrases in order to establish the visibility of the researched websites in the Google search engine. Research results are presented in the Table 6. The table presents: place of the website

in the search results after typing of the keyword (or phrase) in organic results / place of the website in the search results after typing of the keyword (or phrase) in sponsored links.

Table 6. Website position in the search engine results in Google.pl after typing of specific phrase (natural / sponsored results)

Phrase / website	Agito.pl	Neo24.pl	Electro.pl
„AGD”	0/0	0/3	21/0
„dishwashers”	0/0	0/0	19/0
„RTV”	0/0	0/4	4/0
„LCD TV set”	0/0	0/0	9/0

„0” digit indicates that the website was not visible in first five search results (in case of organic research) and not visible at the first page of the search engine (in case of sponsored links).

Research results indicate that Agito.pl has practically no visibility in the Google search engine, both in natural and sponsored links. Neo24.pl also is not included in the first five natural research results, although it is in one of the exposed positions in sponsored links, displayed after typing the phrases: „AGD” and „RTV”.

The highest visibility is reached by the Electro.pl website, which is shown at the first place of natural search results in Google, answering the inquiry for the phrase “RTV” and “LCD TV set”. It is also present in second and third page of the natural results after typing the “AGD” and “dishwashers” keywords. Website is not visible in sponsored links.

The result of visibility analysis in the Google.pl search engine resulted in the following score for the selected websites:

- Agito.pl – 0 points,
- Neo24.pl – 2 points,
- Elektro.pl – 4 points.

Website reach research

Data from the analytical website Alexa.com and the data from the research company website Gemius – Ranking.pl were used in the research of website reach. Table 7 collects the results the traffic research of researched websites during the period of 10.2008 – 01.2009.

Agito.pl website was determined as the website with the largest reach, according to performed research.

The reach of the website is three-times larger than the one of Neo24.pl. At the same time, the 356 position in the national website statistics indicates that the brand is well known among Polish internauts. Detailed research, however, reveals some unfavorable tendencies. Agito.pl slightly decreased the number of visits in last three months, whereas the competition increased its reach (Neo24.pl by 56%, Electro.pl by 68%).

The tendency, unfavorable for the leader, is also the decrease of the user activity and engagement in website pages browsing, which decreased in last three months by 9%. Competition noted growth in this matter (respectively by 13% and 8%) and the absolute winner in the number of browsed pages is the Neo24.pl website.



Figure 4. Neo24.pl website visibility in sponsored links for the „AGD” search phrase (source: Google.pl)

Table 7. Results of the traffic analysis of researched websites during 10.2008 – 01.2009

Researched value	Agito.pl	Neo24.pl	Electro.pl
Website reach in the global population of internauts	0,00347%	0,00076%	0,00116%
Monthly visit number	90908	19910	30390
Change of reach in previous 3 months	-1%	+56%	+68%
Statistical place in the Polish website ranking	356	1361	1160
Number of viewed website pages during single visit	4,93	6,00	3,91
Change in the number of viewed website pages during previous 3 months	-9%	+13%	+8%

It is important to mention that further study show little probability of relation between the number of browsed pages and the navigation solutions used in the website – every website required 2 clicks to reach the desired group of products (and reloading of the website).

Agito.pl was awarded with the highest note in the visibility study. Identical score was given to Neo24.pl and Electro.pl. Even though the first site notes smaller number of visits, larger number of pages is browsed during each visit (therefore the engagement of the user in website browsing is more considerable). The marks awarded in the partial research are:

- Agito.pl – 5 points,
- Neo24.pl – 3 points,
- Elektro.pl – 3 points.

Construction of visibility and website e-publicity in selected e-commerce related websites (Allegro.pl, Opineo.pl, Ceneo.pl)

This part of the research was used to determine the visibility of researched websites usually connected with internet users related with e-commerce. Websites, with the highest visibility in the following groups, were selected: market organizer, e-commerce systems opinion aggregator, price comparison systems. On the basis of Polish website reach study the following sites were selected: Allegro.pl, Opineo.pl and Ceneo.pl.

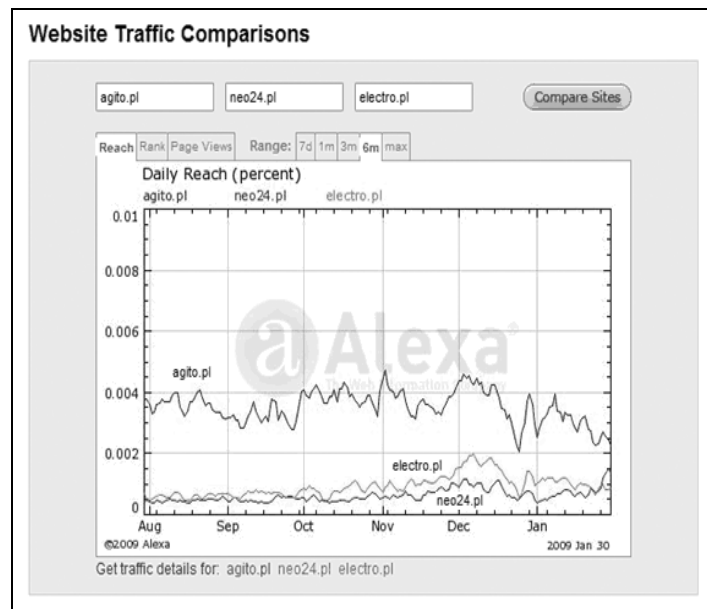

Figure 5. Reach of researched websites during 08.2008 – 01.2009
(source: Alexa.com)

Reach for Agito.pl: ⓘ				
Percent of global Internet users who visit this site				
Yesterday	1 wk. Avg.	3 mos. Avg.	3 mos. Change	
0.0023%	0.00242%	0.00347%	↓ 1%	

Traffic Rank for Agito.pl: ⓘ				
Alexa traffic rank based on a combined measure of page views and users (reach)				
Yesterday	1 wk. Avg.	3 mos. Avg.	3 mos. Change	
45,926	41,381	24,875	↓ 161	

Page Views per user for Agito.pl: ⓘ				
The number of unique pages viewed per user per day for this site				
Yesterday	1 wk. Avg.	3 mos. Avg.	3 mos. Change	
4.6	5	4.93	↓ 9%	

Figure 6. Changes in the statistics of Agito.pl during 10.2008 – 01.2009
(source: Alexa.com)

Neo24.pl has the highest visibility among the researched websites. At the same time the website makes the worst impression with relation to e-publicity. However, the marks posted by the users are relatively high, even though the number of negative opinions is considerably higher than in the websites of the competition.

It is important to mention that negative opinions are usually with similar content (especially focusing on the difficulty to contact with the e-commerce website employees), what makes them even more significant.

It is also important to emphasize that 6,4% of negative and neutral comments in Allegro.pl 10% in Opineo.pl considerably undermines the reliability of the seller³¹.

Electro.pl is definitely receiving the best marks from the internet users among all of researched websites. Even though the website is not performing any additional sales with the use of Allegro.pl, its scale and scope is enough for effective individual performance. It is important to mention that in Opineo.pl and Ceneo.pl the Electro.pl website collected the biggest number of comments (what indicates a relatively high level of sales), with only 2% of negative and neutral comments.

In this part of research the highest mark was awarded to Electro.pl, which, even though it is not visible in Allegro.pl (probably due to the specialized sales with self e-commerce system and high order level), has the biggest number of comments in Ceneo.pl and Opineo.pl, with the highest amount of positive comments.

Agito.pl and Neo24.pl were evaluated similarly. In case if Neo24.pl one can speak of higher visibility, due to the use of the Allegro.pl action platform for current operations, even though the relatively high level of negative comments is decreasing the credibility of the website.

The marks awarded in the partial research are:

- Agito.pl – 3 points,
- Neo24.pl – 3 points,
- Elektro.pl – 4 points.

Total evaluation with the consideration of weights awarded in the visibility (V) research is as follows:

- Agito.pl – 1,8 points,
- Neo24.pl – 2,5 points,
- Elektro.pl – 3,7 points.

³¹ Share of positive comments in total number of comments for the transactions below 98% makes it impossible for the user to be awarded the title of a Super Salesman status, which indicates high quality of service.

6.2 Usability study

Usability study based on the website usage scenario

The research was performed with 5 person focus group of potential RTV (multimedia)/AGD (domestic appliances) e-commerce website users. The following scenario, for the needs of usability study, was determined:

Scenario of dishwasher purchase in e-commerce RTV/AGD website:

Customer is searching for AAA class dishwasher, with relatively low noise level, program countdown possibility, ½ input option, startup delay, possibility to wash large plates (movable basket, long manufacturer warranty. After the selection the customer purchases the product without logging in and expects credit card payment possibility.

The research results indicated that none of the researched websites allows the advanced search of products, which include standard parameters of the equipment. Such attempt was made, in limited scope, in the Allegro website, but the result of this search engine is not satisfactory. Neo24.pl and Electro.pl offer similar product comparison systems. Even though this solution does not allow quick product search, it allows performing detailed product comparison. It is important to emphasize that in every of researched websites searching for a product with specific features (without naming the manufacturer or price) is connected with slow and time-consuming searching through product group lists.

All websites have a considerable speed of reaching product groups by the user – selection of dishwashers was reached after 2 clicks. All websites allow adding products to the cart without the need to log in.

However, only Neo24 and Electro.pl allow performing the purchase without earlier user registration. Electro.pl has missing data for some of the products, what does not allow comparing them with other products. Neo24.pl website has contradictory information on the time of warranty, according to the information of the manufacturer. All websites allow performing purchases with credit cards.

The marks awarded in the partial research are:

- Agito.pl – 2 points,
- Neo24.pl – 3 points,
- Elektro.pl – 4 points.

Table 8. Visibility and opinion about selected websites connected with e-commerce

Researched factor	Agito.pl	Neo24.pl	Electro.pl
Presence in Allegro.pl	NO	YES	NO
Opinion in Allegro.pl	-	shop sells products via Allegro.pl, with 93,6% positive comments	-
Presence in Opineo.pl	YES	YES	YES
Opinion in Opineo.pl	score: 9,0/10 votes: 2595	score: 8,8/10 votes: 1515	score: 9,6/10 votes: 9661
Presence in Ceneo.pl	YES	YES	YES
Opinion in Ceneo.pl	score: 4,5/5 votes: 4422	score: 4,5/5 votes: 6495	score: 4,5/5 votes: 18178

Table 9. Expert usability analysis results

Researched factor	Agito.pl	Neo24.pl	Electro.pl
Are the used colors tuned down, not aggressive, relevant to presented content?	YES	YES	YES
Is the navigation usable an efficient?	YES	YES	YES
Does the product search work properly?	NO	NO	NO
Does the product comparison work properly?	NO	YES	YES
Is the presented information understandable?	YES	YES	YES
Does the system clearly inform the user about his current position?	YES	YES	YES
Is the purchase procedure clearly described?	YES	YES	YES
Is the product purchase procedure undisturbed?	NO	YES	YES
Is it always known at which stage the user is in the purchase process?	YES	YES	YES
Are the help systems available?	YES	YES	YES
Sum of positive marks:	7	9	9

Expert usability analysis

Website usability was evaluated with the usability criterion checklist elaborated on the basis of literature analysis, with particular use of „Nielsen’s heuristics”. Elaboration was prepared in the form of checklist filled in for each website.

The marks awarded in the partial research are:

- Agito.pl – 4,2 points,
- Neo24.pl – 5,4 points,
- Elektro.pl – 5,4 points.

Total evaluation with the consideration of weights awarded in the usability (U) research is as follows:

- Agito.pl – 3,1 points,
- Neo24.pl – 4,2 points,
- Elektro.pl – 4,7 points.

6.3 Accessibility study

Accessibility research at 1 level of WCAG W3C with the Cynthia validator

Cynthia system, possible to access at the ContentQuality.com website, was used to perform the research. This system allows validating websites according to the compliancy with:

- Section 508 (fragment of "The Rehabilitation Act (29 U.S.C. 794d)" called "Electronic and Information Technology",
- WCAG 1.0 standard of W3C organization according to 1, 2, 3 priorities.

Due to the fact that WCAG 1.0 standard, especially at level 1, is included in EU legislation according public administration website accessibility – it was selected for this research.

Result of the research indicated that none of the researched websites was compliant with all requirements of the first (basic) level of WCAG W3C accessibility. The smallest failure (with relation to a selected criterion) concerned Agito.pl, other more considerable (with relation to many criteria) concerned Neo24.pl and Elektro.pl websites.

The marks awarded in the partial research are:

- Agito.pl – 5 points,
- Neo24.pl – 3 points,
- Elektro.pl – 3 points.

Table. 10. Accessibility research of accessibility research at level 1 of the WCAG W3C with the Cynthia validator

	Agito.pl	Neo24.pl	Elektro.pl
Number of spotted errors at the main page according to the guidelines of priority 1 WCAG 1.0	3	8	9

Table 11. Research of the triad for the crucial accessibility elements – expert analysis

Researched factor	Agito.pl	Neo24.pl	Elektro.pl
Possibility to display the website in internet browsers with different engines	2	2	2
Site map in text version or website text version	1	2	2
Possibility to change the website font size	0	0	0

Table 12. Total website evaluation result in V-U-A method research

Researched feature	Agito.pl	Neo24.pl	Elektro.pl
Visibility (V) – weight 0,4	1,8	2,5	3,7
Usability (U) – weight 0,4	3,1	4,2	4,7
Accessibility (A) – weight 0,4	4,2	3,4	3,4
Total mark (0-6 scale)	2,80	3,36	4,04

Research of the triad for the crucial accessibility elements – expert analysis

On the basis of literature analysis, concerning website accessibility, it was determined that the most significant factors influencing the website accessibility are:

- the possibility to display the website in internet browsers with different engines (Internet Explorer 7.0.6, Opera 9,60 and FireFox 3.0 were selected for tests),
- site map in text version or website text version,
- possibility to change the website font size.

The research had the following scale with relation to different criteria:

- 2 – total criterion fulfillment,
- 1 – partial criterion fulfillment,
- 0 – no fulfillment.

Research results are collected in table 11.

The research results indicate that all websites are functioning properly in the three main web search engines. Neo24.pl and Elektro.pl had the website text map, which is a considerable navigation facility for people who use website voice readers. None of the websites allowed changing the font size neither from the menu (change style) or the internet browser.

The marks awarded in the partial research are:

- Agito.pl – 3 points,
- Neo24.pl – 4 points,
- Elektro.pl – 4 points.

Total evaluation with the consideration of weights awarded in the visibility (V) research is as follows:

- Agito.pl – 4,2 points,
- Neo24.pl – 3,4 points,
- Elektro.pl – 3,4 points.

6.4 Total website evaluation result in V-U-A method research

On the basis of visibility, usability and accessibility study complete evaluation of the feature combination, which characterizes researched websites, was elaborated. The evaluation is collected in table 12.

7 Summary

Visibility, usability and accessibility issues of websites are more often present both in scientific literature and practical guidebooks. Usually these publications deal with these issues separately. The complex evaluation of factors, formulating the incoming website traffic, collection management methodology available also for MSP enterprises is lacking. Research results presented in the article indicate that the B2C e-commerce sector of Polish market is using the visibility, usability and accessibility factors in order to improve the sales competitive position of the websites.

Fierce competition is especially visible in the scope of creation of website visibility. Whole spectrum of user reaching possibilities is used here, including positioning in web search engines and other forms of internet advertising. On the other hand, the example of Agito.pl shows the results of lack of interest in website visibility policy by the market leader (with relation to the number of visits). Polish e-commerce market looks much worse in terms of website usability and accessibility. Research websites definitely are difficult to operate by people who require higher website accessibility. There also major problems in usability in selected websites. The most important fact is that none of the websites allowed to realize the determined purchase scenario, based on standard customer behavior

known from traditional shops. In one of the researched websites the obligatory registration is still required, what has a negative influence on the business, even though it is said to be a basic and typical usability problem. Results of the research performed on such small sample are difficult to generalize and relate to the whole B2C e-commerce sector. However, this problem definitely needs more attention and should be researched in future studies.

8 References

- [1] Bickerton P., Bickerton M., Pardesi U. - *Cybermarketing*. Butterworth-Heinemann, Kidlington 2000.
- [2] Gąsiorkiewicz A. - *Marketing internetowy w wyszukiwarkach jako narzędzie kreacji wartości biznesu* [in] XI Konferencja Komputerowo Zintegrowane Zarządzanie. Zakopane 2008, pp. 338-345.
- [3] Kalbach J. - *Designing Web Navigation: Optimizing the User Experience*. O'Reilly 2007.
- [4] Kasperski M., Boguska-Torbicz A. - *Projektowanie stron WWW. Użyteczność w praktyce*. Helion, Gliwice 2008.
- [5] Kaushik A. - *Web Analytics: An Hour a Day*. John Wiley and Sons, New York 2007.
- [6] Krug S. - *Don't Make Me Think: A Common Sense Approach to Web Usability*. 2nd ed., New Riders Press, 2005.
- [7] Moran M., Hunt B. - *Search Engine Marketing, Inc.: Driving Search Traffic to Your Company's Web Site*. IBM Press, 2005.
- [8] Moruń K. - *Odpowiedzialność prawna za odesłania w Internecie* [in] Przegląd Prawa Handlowego, No. 12, 2007.
- [9] Nielsen J. - *Enhancing the explanatory power of usability heuristics*. Proc. ACM CHI'94 Conf., Boston 1994.
- [10] Nielsen J. - *Heuristic evaluation* [in] Usability Inspection Methods (ed. Nielsen J., Mack R.L.). John Wiley & Sons, New York 1994, pp. 25-62.
- [11] Nielsen J., Loranger H. - *Prioritizing Web Usability*. New Riders Publishing, 2007.
- [12] Strauss J., El-Ansary A., Frost R. - *E-Marketing (4th Edition)*. Prentice-Hall, New Jersey 2005.
- [13] Thatcher J., Burks M., Heilmann Ch., Henry S. L., Lauke P. H., Rutter R. - *Web Accessibility: Web Standards and Regulatory Compliance*. Friends od. ED, 2006.

COMPUTER INTEGRATED ENTERPRISE IN THE MRP/ERP SOFTWARE IMPLEMENTATION

Andrzej KAMIŃSKI

Faculty of Management

Warsaw University of Technology, 02-524 Warszawa, Poland

e-mail: a.kaminski@wz.pw.edu.pl

Abstract: The aim of this elaboration is to present selected methodology, application and design issues connected with the process of complex enterprise informatization in the implementation process of an IT system. Role of the integration process in economic information processing and directions of integration activities in the scope of the IT systems of the enterprise are presented in the first part of this elaboration. Afterwards, technical features of an integrated IT system are characterized. Thesis that particular systems are comparable in the scope of functionality of the basic areas of activity of the enterprise, such as: accounting, material and stock planning, sales and invoicing, human resources, wages, can be formulated on the basis of the national portfolio of ERP (Enterprise Recourses Planning) packages. On the other hand, the cost of license purchase as well as the implementation activities, reaches the level from tens of thousands to few million PLN. Differences in the levels of investments are determined with: scope and complexity of the endeavor, functionality and system architecture as well as the cost of extension and modification of provided program modules.

Key words: IT system, MRP, ERP, computer integrated enterprise, methodology of complex enterprise informatization program.

1 Introduction

The aim of this elaboration is to present selected methodology, application and design issues connected with the process of complex enterprise informatization in the implementation process of an IT system¹.

Attempt of classification of the ERP² software was made, with the differences in software architecture of various systems born in mind. Main classification

¹ ERP class system (Enterprise Resource Planning) is an integrated, highly effective, multi-access IT system – designed for the needs of complex management of manufacturing enterprise. ERP systems, subjected to continuous improvement and development, became the most common tools for production managing and planning in large and medium enterprises (70% of computerized manufacturing enterprises in highly developed Western European countries is basing their business activities on MRP standard IT systems). ERP systems originate from the Material Requirements Planning standard elaborated in the seventies. Next generation — MRP II — was extended with sales processes elements as well as elements that support the decision making processes at the strategic production management level.

² Technical architecture of integrated ERP system includes four basic application software layers: user interface (collection of connected graphical forms that function in the environment of Windows, Web, Linux etc.), business applications (software modules and components elaborated by a team of analysts, designers and programmers from the provider of the integrated package), development and new application creation environment (administrative tools, form generators, report generators, code generators) and data resources (relational database, which records all economic operations).

criterion was the adaptation level of the system to the needs and specific character of selected industrial organization.

Methodology concept of complex enterprise informatization program, with special attention for analytical and design activities, is also presented in this elaboration. The aim of such activities is the substantial preparation of the industrial organization to the implementation of integrated and compliant with standards ERP system. This process is initiated by the elaboration of informatization strategy, followed by complete system analysis and the construction of system and software infrastructure.

Final effect is the restructuring (industrial conversion) of the enterprise through ERP package implementation, cost reduction, improvement of economic indicators and improvement of operational and managerial processes.

2 Integration function in the process of industrial information processing

Integration process is based on the connection of functional elements with relations in a way that they become part of a specific structural entity ([6], p 55). According to the definition, integration process is the activity or a sequential set of activities, which need to be performed in order to reach desired effect, e.g.

joining two industrial enterprises – connection of functions, organizational structures, technological processes, pricing and product quality policies.

Relating the quoted definition to sciences from the scope of economics and enterprise management, professor E. Niedzielska introduces the concept of integrated management environment defined as “economic, technological and social micro-space of common endeavors (manufacturing, services, investment, distribution, marketing and other), which depend on complex (multi-module, multifunctional) integrated industrial IT systems of market partners - Business Information Systems” ([14], p. 45).

According to Gartner Group, from the perspective of informatization of the entirety of enterprises economic processes, integration is the “realization of large, complex IT projects that concern elaboration and/or creation of architectures and applications adjusted to specific customer requirements as well as integration with new or existing computer or telecommunication software and hardware”. In this definition the crucial integration criterion are the size and complexity of the projects dealing with IT technology development (acc. to [13], p. 7).

On the other hand professor M. Bazewicz considers the IT system integration issues on technological, data-logical (concerns programs, data formats and structure, programming languages, facts and events description language) and infological (representation of the knowledge in the system) levels. He also proves that the most important condition of IT system cooperation is the semantics, which is the consistency of concepts used to describe sentences, facts, events. Successive consistency level is the unification of measures, norms and classification rules ([2], p. 103).

From the perspective of technological factors, integration is the “complete and compliant set of international technological standards and functional specification interfaces, services and formats to assure inter-efficiency and transferability of applications, data and human resources.” ([5], p. 22). Integration issues of listed media in the IT systems, using multimedia technology, are described in the work [7].

Economic process integration is also an essential element of integration activities. Economic process integration is defined as identification, documentation and management of relations taking place between particular processes. The aim of these activities is to reach synergy effect, which means that all mutually con-

nected processes, organizational cells, information channels and control mechanisms are functioning optimally as a complex economic (entity) system ([19], p. 16). Integration of economic processes allows the control over information, material and energy flow beyond the boundaries of the enterprise, what is possible due to the connection of all necessary heterogenic functional units in order to improve communication, cooperation and coordination in given enterprise. Heterogenic functional units of the enterprise, which are to be integrated, are: IT systems, hardware, applications and human resources. As a result the enterprise functions as an entirety, increases global productivity, flexibility and change and innovation introduction.

Standardization of economic information flow system document forms is the basic condition for the information processing automation. As a result of content analysis of particular documents, it is necessary to determine the following: are there multiple documents reflecting the same economic event, is the data in different documents not repeated and whether there are differences of the description of particular economic events in various documents?

In order to allow electronic document transfer and exchange it is necessary to use determined recording format standardization. For example in the construction of WWW websites the standard document recording format is the HTML language (Hyper Text Markup Language). HTML language was elaborated on the basis of SGML meta-language (Standard Generalized Markup Language) ([18], pp. 183-198).

This technology allows publishing and presenting documents in the Internet, independent of presently used system and hardware platform. Alternative solution would be the usage of the commonly accepted text file format “txt”. However, this format is used only to record the content of the document, whereas HTML allows transferring both the text and graphical content of the document. Document standardization methods, together with practical examples, are presented in the work ([4], pp. 12).

Enterprise model elaboration is the integral element of the integration activities. It is a multilevel, logical representation of the economical processes ([9], pp. 55-71). Using special dedicated software (e.g. ARIS Toolset, Corporate Modeler) allows simulating organizational changes, process relation evaluation and flexible transferring of resources.

3 Integration of enterprise IT systems

Integration in manufacturing enterprises was the main premise CIM (Computer Aided Manufacturing), integration of „automation islands” that were created as a result of rapid and intensive automation that took place in the seventies and the beginning of the eighties. CIM concept allows an effective usage of IT technologies as part of the computer production integration.

However, integration concerns also other parts of the enterprise, where the main goal is the “information islands” integration, connection of dedicated subsystems, data redundancy elimination through the creation of integrated database systems and multi-accessibility of the IT system through the creation of customer-server applications.

In the IT systems integration process it is important to consider two independent possibilities of integration activities: complete system integration – possible as a result of technological unification of functional modules, data structures, processing methods, programming tools, communication protocols and the occasional system integration – based on the elaboration of data exchange platform between independent domain subsystems.

First solution creates the possibility for full integration of transactional systems. The aim of this process is strive for the registration and processing of all economical operations in homogenous, both functionally and technologically, integrated system. For example in the finance and accounting department all processes connected with financial documents processing, starting from account plan unification and finishing with the elaboration of common activity procedures, will be subjected to integration processes. Implementation of complete enterprise IT system integration method in practice means high cost connected with purchasing of application software and modernization of the hardware infrastructure, relatively long time of the implementation and the necessity to perform organizational changes.

Second solution is the maintaining of decentralized transactional processing systems, creation of finance data consolidation and optimization according to analytical processing. Presented concept creates the basis for the creation of data warehouse, creation of multilevel data representation models – OLAP technology (On-Line Analytical Processing) as well as the imple-

mentation of intelligent knowledge gathering – Data Mining tools.

From the perspective of CIM, integration issues concern the IT systems in the mother enterprise (internal integration). However, integration process can concern also the creation of relations between IT systems of different enterprises (external integration).

For example in the design of stock management aiding system designated for an enterprise that has regional and geographical agencies, dispersed architecture can be used in order to process operational data in real-time. Therefore, in case of a considerable customer order for products not available in stock of the local supplier, crucial factor being the delivery time, it is possible to realize the order due to the information about the stock levels of other agencies and partners.

At this stage the technological analysis of the system implementation aspects is not relevant. It is crucial to make a strategic assumption that the provision of information that is reliable and up-to-date, which is possible with transactional processing of dispersed economic information, is one of the key success factors. It is also possible to include suppliers into the system (Business to Business), in order to reduce the stock cost, in further perspective.

In another example – enterprise functioning in a holding structure, created of smaller capital-connected companies – the issue of data integration for the needs of current controlling and reporting should be approached differently. With the assumption that the Board expects weekly reports on the level of sales in particular companies and also periodical analytical reports for the capital group it is reasonable to create a data warehouse. In this case feeding the central data warehouse with data should be realized with, so called, lot and periodical method, using the data replication mechanisms offered by database servers. It is reasonable to consider publishing of some of the statistical data in the internet in further perspective.

The main requirement for the integrated system, in every described example, is the necessity to have updated operational data. Final user is not interested in the data integration method but rather in the fulfillment of certain formal requirements: up-to-date data and the standard inquiry response time of the system.

It is important to emphasize that there is a considerable difference between the transactional system operating in the online architecture and the analytical system fed

in the lot and periodical regime. Proper evaluation of the real needs determines the selection of certain technical architecture of the system.

4 Classification of integrated systems

Integrated system consists of standard modules designated for the servicing of all data transfers that support the functioning of the industrial organization. Integrated system is designated for the computer aiding of economic operation processing at operational and managerial levels:

- operational level - employees benefit from process automation e.g. one time introduction of source documents to the system, possibility to gain access to the functions of the system that allow to realize certain tasks,
- managerial level - high management has the possibility to monitor the financial condition of the en-

terprise, check the current product and raw material stock, planning of rational logistics, maintenance and action in case of irregularities.

It is essential to evaluate the possibility of adjustment of given package to the character of selected industrial organization, from the perspective of the complete business processes informatization concept. Therefore it is reasonable to elaborate the classification of integrated systems, with the evaluation of adaptive possibilities as a division criterion (see Figure 1).

Classification of integrated systems:

1 Dedicated systems

Dedicated systems are designed on the basis of full system analysis of the industrial enterprise. Technological tools of external software companies are used in the application software construction process.

Integrated IT systems of the enterprise	Parameterization scope	Remarks
Dedicated systems	very high	Systems designed on the basis of complete system analysis of the industrial organization. Tools from external software companies are used in the process application software design
Standard systems	low	Implementation process is a compromise between enterprise requirements and system functionality
Universal systems	medium	Computer aiding of typical business processes (e.g. Sales, Financial Accounting, Stock Management) independent of the profile of enterprise activities
Closed systems	low	These systems are replicable and designed for servicing small and medium enterprises. They differentiate with low cost of application software, due to mass sales. Scope of modification is limited with the material indexes, file index definitions etc
Open systems	medium	Parametric systems that allow to adjust user system interface and creation of new functional modules
System interface parameterization	medium	Scope of expectations and changes includes graphical interface structure modification and content of the generated reports
Technological system customization	high	Systems equipped with integrated programming environment designated for the creation of modules servicing specific enterprise processes
Branch systems	medium	Systems designated for servicing of particular industrial branches (e.g. electro-energetic branch)

Figure 1. Classification of integrated systems

(source: self study)

2 Standard systems

2.1 Universal systems

These systems include supporting of business processes (e.g. Sales, Controlling, Stock Management), independent of the company's profile. Universal systems include:

2.1.1 Closed systems

These systems are replicable and designed for servicing small and medium enterprises. They differentiate with low cost of application software, due to mass sales (in thousands of pieces). The main disadvantage of such systems is their low flexibility in adjusting to the needs of the enterprise. Scope of modification is limited with the material indexes, file index definitions etc.

2.1.2 Open systems

Systems that allow to adjust system's interface and create new functional modules. Open systems include:

- Open systems allowing modification of key functional parameters. Parameter is the variable, which after taking certain value (setting) triggers a specific action of a particular system module ([17], p. 352). Setting of some parameters should be treated as permanent (in a functioning system it is not advisable to change the parameters without previous consulting with the specialists). For example one of the parameters defined as "permanent" is the multi-serviceability (the possibility to simultaneously service the accounting of many enterprises) and the "variable" parameter can be the currency format (e.g. display of the currency with two digits after the coma).
- Open systems allowing modifying the user interface. User interface layer includes the graphical interface of the application, which is the normalized set of mutually connected forms, consistent for the whole package according to ergonomics of the steering elements placement (action buttons, options menu) as well the elements allowing the introduction, edition and modification of data (data labels, text fields, scroll-down lists). Scope of requirements and changes includes the modification of the graphical interface of the application and the informational content of generated reports. It is important to emphasize that the servicing of the report generator does not require any programming skills and is based only on discovering the character of particular tool and convention, in which the inquiry is constructed and the final layout of the re-

port (printout) is determined. Modern reporting tools are equipped with visual environment of SQL inquiries in order to simplify the design process. Console of the system administrator is an integral system of the ERP package. Assigning authorization level for the particular functional modules or objects as well as the graduation of authorization level is performed with the administrator's console.

- Open systems allowing technological system customization. Such systems are equipped with integrated programming environment (application generators) designated for the creation of extensions of standard functionality of given package and creation of new modules, which would service the specific processes of the enterprise. One of the main features of the environment is the use of visual modeling tools for the user dialogue form, high automation level of standard programming activities and isolation from the system software layer (data transferring protocols, printout controlling, authorization control). It is crucial to point out that the integrated programming environment is not typical only for "higher-class" ERP systems. Currently this component is present in packages designated for small and medium enterprises.

For example the Navision Attain³ package is equipped with a set of tools for the creation and modification of particular layers of the software. Architecture of this package consists of three basic layers: presentation layer, design layer and code layer (see Figure 2).

First layer is the "Presentation layer". Graphical application interface consists of electronic forms collection, which is used by the users in daily system exploration. Forms in this layer are grouped in thematic structures (modules). Module is used to service the typical areas of the enterprise activities (e.g. Sales, Stock, HR –

³ Microsoft Business Solutions - Navision is a family of ERP packages (Microsoft Business Solutions - Navision Attain and Microsoft Business Solutions Navision Standard), which were created by a Danish enterprise Navision Software, later intercepted by Microsoft, currently supported by the Microsoft Business Solutions department. Navision Attain is an integrated IT system, designated for medium enterprises. Navision consists of the following modules: main book, material assets, sales and debt, purchasing and liabilities, stock, orders, human resources – wages, production. System allows multicurrency money transfers, selection of various languages of the user interface and usage of custom Navision Developers Kit programming tools. It works in the client-server environment using Windows NT/XP/VISTA and IBM AIX platforms. Microsoft Business Solutions - Navision Standard is a solution designated for small enterprises (up to 10 users).

wages etc.). User does not have the possibility to interfere with the data objects (text boxes, labels, scroll-down lists) structure displayed in particular forms and to change the content generated by the reporting system. General rule of dialogue boxes construction and data object grouping, graphical layer and user communication are consistent and ergonomically correct. Similarly, the set of inbuilt rules responsible for the correctness validation of inserted data as well as the navigational mechanism (system menu) and the control mechanism are uniform for the whole system.

Second layer is the “Design layer”. This layer allows access to properties and settings of objects. These tools were hidden beneath the layer of electronic forms of the first layer. Integrated project environment shares the mechanisms necessary to create new forms and for the editing of the existing ones. Apart from the interference in the graphical layout of the form, adding new data objects and connecting them to the objects from the database, is also possible.

It is important to explain that the forms are only the representation of data stored in the tables. Therefore, design stage needs to connect the data objects in the form with relevant fields in the data tables.

The final (third) layer is the “Code layer”. This layer allows constructing validation control mechanisms introduced by the user of the input data, creation of business rules and complex processing operations (e.g. the commission calculation mechanism for the salesman with relation to current sales results of products and services and historical data).

Designing and programming environment of the Navision Attain system allows isolating the IT technician – programmer from the table, field and relation creation mechanisms for particular database management systems. For example, “Design layer” allows performing operations connected with adding of attributes to existing data tables.

This operation is relatively simple and comes down to selection of the source table and inserting the name of new attribute together with the determination of its type. Programming and design environment automatically generates scripts in SQL language, which perform proper modifications in the database structure from the server side.

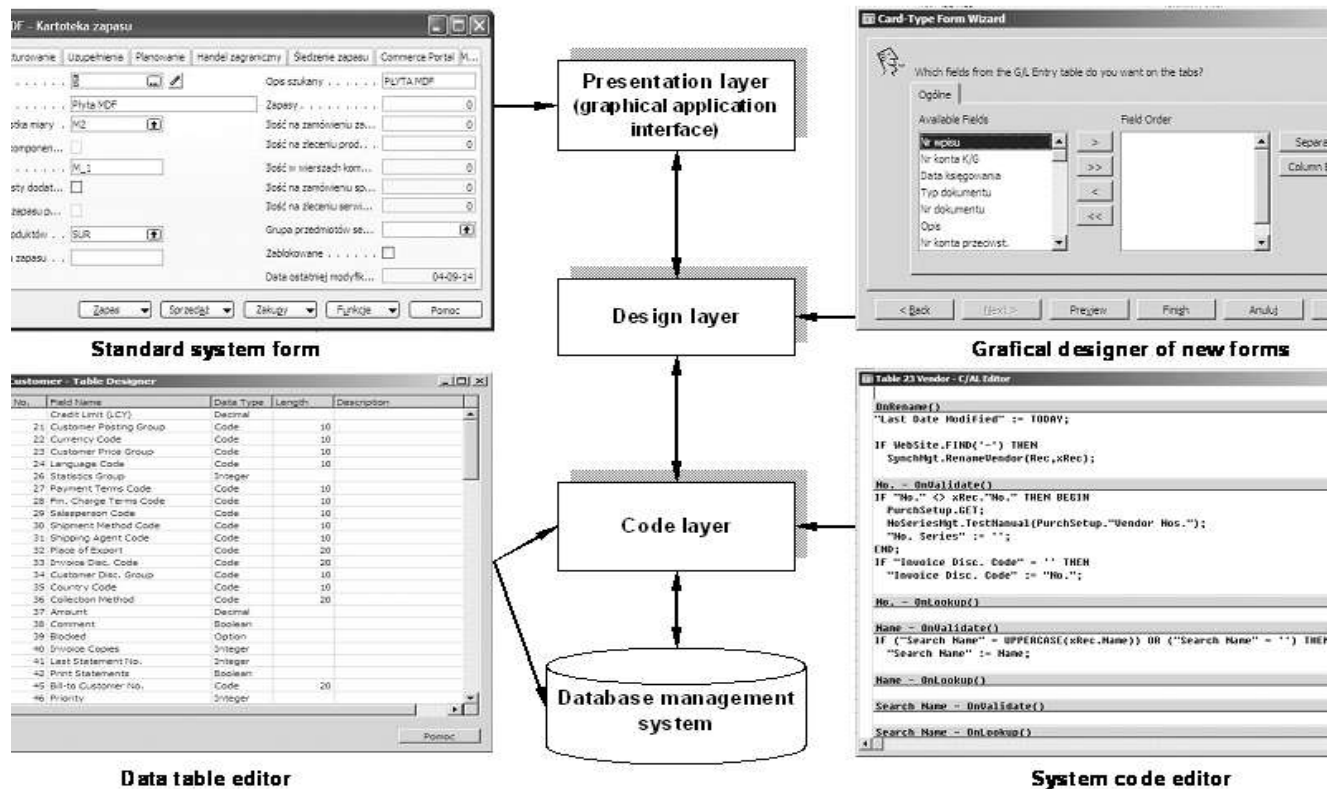

Figure 2. Architecture of integrated IT system
(source: self study)

2.2 Branch systems

Branch systems are designated for the servicing of selected trade lines and industrial branches (e.g. energetic, chemical, textile industry) as well as custom enterprise activities profiles. This category of IT systems is characterized with a higher level of functional advancement than in case of universal systems – as a result of technological modifications of standard system modules and creation of new solutions, typical for particular industrial branch. For example the JBA Company provides branch solutions for manufacturers and distributors of food, beverages, clothing and shoes as well as the automotive industry ([1], p. 30).

In detailed approach:

- food system was created according to the requirements of food manufacturers and distributors, especially with relation to hygiene and quality; many companies are using the system e.g. bakeries, meat-processing industry,
- drinks system fulfills the requirements of manufacturers and distributors of alcoholic and non-alcoholic beverages, who need to obey strict technological regimes of fluid manufacturing and package material management,
- automotive system – version designed for the automotive industry.

Reference models are used In order to perform the comparison analysis and evaluation of the enterprise processes compliancy with representative solutions for particular branch. For example the ARIS–Toolset is provided with branch reference models, such as: automotive industry, furniture, paper. Branch reference models support the selection of standard software, because they can act as requirement specification with relation to particular business solution ([12], p. 209).

Summing up the deliberations above – implementation of branch systems is dedicated with the following technical and economical premises:

- cost of the branch system implementation is lower than the cost of universal package, it is easier to learn the basic functionality of the system for the final users as well as the need for the functional adaptation of the whole system and its communication media is lower,
- significant similarity of particular enterprises in selected branch is visible, what leads to the possibility of sales scale effect increase.

5 Organization of the informatization process of the enterprise

Design of the complex informatization process organization is the basic element of the technical and organizational project of the industrial conversion of the enterprise. The aim of this process is to: create stable hardware and system infrastructure, link exploited domain subsystems in the integrated system formula as well as, in further perspective, creation of industrial organization knowledge management system.

Stage 1 Elaboration of the industrial object informatization strategy

Strategy is a concept with many different meanings and is used in various areas of human activity, especially in military activities, economy and the collection of enterprise organization and management sciences.

The aim of strategic organization diagnosis is ([15], p. 172): „understanding its commercial potential now and in the future. Skills and resources, which, in comparison with the competition, decide about the strengths and weaknesses of the enterprise in the market, are the substance for the potential. Basic areas of strategic diagnosis procedures application are: marketing and product distribution policy, logistics, finance, human resources, technology and production management. IT is the integrating element.

It is purposeful to consider the complex informatization issue in both macro scale, from the perspective of the whole enterprise, and micro scale – evaluation of technical, functional and using quality of systems and application that support particular organizational units. Key requirements towards the IT technology need to be distinguished and the complex informatization plan has to be elaborated in the strategy stage. Tasks connected with a detailed analysis of informational content as well as the implementation technology should be postponed until the system analysis and system design is prepared. Strategy construction stage should be initiated with researching diagnosis. Specification of basic business processes should be performed next. Process knowledge allows to correctly evaluate exploited IT systems, identification of bottlenecks in work organization, documentation flow and data processing technology.

Basic aims set for the research diagnosis are:

- analysis of basic enterprise management system dysfunctions (e.g. product and service distribution,

work organization, production, logistics) and indication of proper corrective activities,

- evaluation of proper IT technology — description of realized functions and the use of benchmarking in order to gain the answer for the following question: how far are the currently used IT products fulfill the informational needs of the users?

It is important to point out that the enterprise management diagnosis system should be realized by external specialists. Evaluation formulated by a group of external experts is necessary due to the fact that usually the technical staff and the managerial personnel have a false belief about the unit they are responsible for. Their perspective is loaded with, so called, parental effect, meaning that usually the parent does not see the drawbacks of his or her offspring.

It is necessary to elaborate the architecture of a new IT system, supporting the entity of recording and processing of industrial events, in the strategy phase. Elaborated concept needs to be strictly linked with current technical IT resources. For example, from the perspective of technological factors and cost of planned investment especially significant is the system task division between the centralized architecture and dispersed processing. This decision is connected with the creation of relevant technical infrastructure (local area network or corporate network), selection of particular software tools groups (e.g. database management system, dispersed transaction servicing support) and elaboration of the preliminary application construction rules (e.g. three-layer software construction, with the use of Internet Explorer internet browser as the client application).

It is crucial to emphasize that the lack of defined guidelines in the scope of the IT system architecture, especially the design of the task division between the centralized architecture and dispersed processing, of forecasted load of future applications and normative acts, form the scope of software production, prevents from making an unequivocal decision about the selection of particular database management system and the programming software packages.

Strategy construction stage is closing the elaboration of decision selection criteria of the IT technology and the formulation of general informatization plan for particular industrial object. Initial estimation of economic cost of activities, connected with the realization of set informatization endeavor, is especially significant at this process stage.

Detailed description of planned informatization strategy is beyond the thematic scope of the article. Issues connected with the comparison analysis of methods and techniques of strategic IT technology, organization and strategy realization methodology planning, strategic development plan and evaluation of opportunities and threats of IT services outsourcing is described in the following works: ([8], pp. 125-148, [11], pp. 207-224 and [3], pp. 487-535).

Stage 2 System analysis

Performance of a complete system analysis of the industrial organization, elaborated due to the implementation of integrated IT system supporting the realization of basic enterprise activities areas, is the next stage of the process.

Basic aim of the complete analysis is the elaboration of source documents flow, input and output data specification and presentation of a consistent concept of enterprise business processes transformation for the needs of the IT system (function, processes and organizational structures reorganization).

The scope of analytical activities should include:

- elaboration of terminology standards and activities documentation rules (key concepts, objects, actors definitions – creation of data dictionary),
- recording and substantial verification of all types of source documents registered in the future IT system,
- elaboration of documentation flow rules, description of particular data fields in source documents and determination of the moment they enter the system,
- description of procedures and algorithms for the processing of elementary data,
- elaboration of information validation and authorization rules,
- determination of the functionality of prepared IT systems, elaboration of deviation protocols, determination of rules, technology, deadlines and cost of claim realization and changes in the standard software,
- detailed description of the structures generated with the reporting system.

System analysis should also include the scope of activities leading to the integration of domain subsystems currently exploited by the enterprise.

It is important to remember about that all independent partial activities (micro analyses), due to their partial nature and focus on problem solving in particular prob-

lem areas, cannot be the basis for the solutions of technical and functional architecture of the integrated system. Synergy effect does not take place. Fragmentary analyses assumptions are not equal to the complete system analysis of the enterprise, due to information redundancy and not-optimal interfaces and integral relations. Such activities can only be used in temporary solutions.

Stage 3 Creation of technical and system infrastructure

The next stage is the creation of technical and system infrastructure in the mother enterprise, its local production and cooperating plants, research and development, administration and servicing units as well as external partners, component suppliers. Technical infrastructure is defined as: design and installation of LAN local area network, determination of cooperation scope in the corporate WAN network (Internet, Intranet), technical parameter specification of computers used as workstations and servers, selection of operational system environment and database platform.

Formulation of the system platform selection criteria, database management system and the analysis and evaluation of existing solutions, with the inclusion of technical parameters of designed IT system, are the integral elements of the technical implementation preparation process. Technical parameters of the designed informational system, crucial due to the selection of operational system platform, consist of: system architecture (central, dispersed processing) number and informational complexity of registered documents (input) and generated comparisons and reports (output), size of data collections, number and complexity of transactions, number of parallel computer stands.

It is necessary to perform installation and configuration procedures of the integrated IT system before the start of implementation activities. Technological properties of the programming environment inbuilt in the ERP package prevent the practical usage of single-system constellation in the production of the integrated system. It is important to bear in mind that the complete information about data objects, interface objects and industrial processes is stored in the ERP package repository. Thus technical or functional changes introduction is system modules generates immediate changes in the production environment of the processing.

Single-system constellation prevents the system parameterization and functional changes and extensions

performance – lack of acceptance test phase is equal to experiments on the “living organism” in practice, possible errors can result in the breakdown of exploited production system.

Introduction of double-system constellations is a relatively low-cost, easy to administrate solution. The following can be distinguished:

- System 1 – development and test system

Changes and functional extensions, result of the ERP package specifics adaptation to the requirements of the enterprise (documentation concerning the scope of changes and the methods of their realization is created during the analytical and design works), implemented in test environment and subjected to a series of technical and integration tests.

- System 2 – production system

Introduction of created (modified) data objects, object interfaces and program code modules (processing algorithms) to the production environment, according to the schedule of the project, are the results of the performance of a series of acceptance tests.

In case of large and complex IT projects it is important to introduce the three-system constellation during the implementation process.

- System 3 – training system

Installation of the training system should be performed in a selected segment of the computer network. Training participants perform a series of processing operations and get to know the advanced functions of the package. Mistakes made in the training process do not have an influence on the functioning of the production system.

Stage 4 Construction (implementation) of integrated IT system

The effect of integration activities is the construction (implementation) of the integrated system that fulfills the normative MRP/ERP standards and is based on a homogenous central database for the whole industrial organization, in the scope of independent domain subsystems exploited by the enterprise. Process of formulation of detailed criterion of analysis and evaluation of future systems and IT technologies is dependent on the nature of particular IT endeavor.

It is reasonable to distinguish three main partial elements of the integrated IT system evaluation procedure: standard functionality, technical architecture, flexibility of the system (see Figure 3):

- standard functionality – set of activities, processing operations, documents (forms, reports, comparisons) available as part of the standard software package, possibility to define business processes of the enterprise without the necessity to interfere with the source code of the application, ergonomic application interface,
- technical architecture of the application software — determines the basic features of the IT system, which are: safety, reliability, openness, scalability⁴, interoperability,
- system flexibility - possibility of the system to adapt to the specifics and needs of particular enterprise (set of vision tools dedicated to the construction graphical application elements e.g. collections, reports, dialogue windows, integrated programming environment dedicated to creation, testing and compilation of new modules and functional expansions).

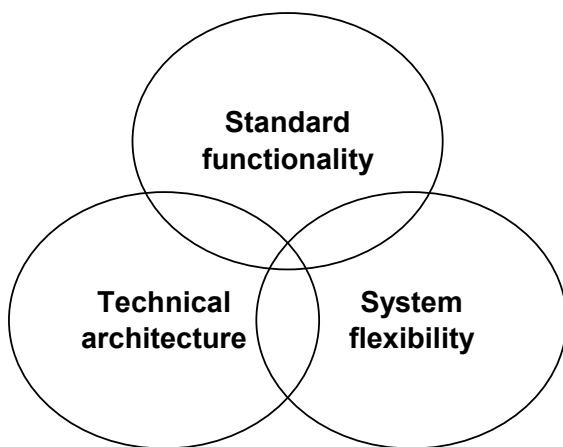

Figure 3. Basic elements of integrated IT system evaluation
(source: self study)

Functionality evaluation, experience of the bidder and license cost calculation of particular modules are the first (initial) stage of the system category procedure selection. Afterwards it is necessary to perform detailed evaluation of technological features. Technical architecture determines the basic system features, which are: scalability, openness and flexibility - system vulnera-

⁴ Scalability – ability of the IT system with an increasing number of users, increasing volume of data collections and expansion of computer network, to function efficiently. The factors that determine system scalability are: architecture (central, dispersed processing), number and complexity of registered documents (input) and generated reports (output), size of data collections, number and complexity of transactions, number of computer workstations.

bility for extensions and modifications. Proper evaluation of technical parameters has a major influence on the real (final) cost of implementation.

Implementation of integrated IT system, aimed at introduction of process management in the enterprise, is a suitable moment for the realization of a number of organizational changes. In practice there is a common theory that the implementation of an integrated IT system is a compromise between finished product functionality and the necessity to perform restructuring in the enterprise. This problem is especially important in case of heterogeneous systems. Detailed determination of restructuring plan and formulation of the methodology and implementation activities schedule as well as elaboration of technical and designing solutions, in scope of standard software adaptation to the character and requirements of the enterprise, is possible on the particular focus, putting on the fulfillment of scalability requirement of the integrated system. Selection of proper operational environment, database platform and technological system architecture should assure an effective functioning of the system, regardless of the load.

Data processing process efficiency, expressed in the number of recorded and generated documents, cannot be limited with the software architecture of the system but only with technical parameters of servers and workstations. In other words, integrated system should work efficiently while processing ten thousand invoices and accounting documents per month as well as when prospecting one hundred thousand invoices and accounting documents per month. The speed of the system should be only limited by the possibilities of available equipment.

6 Summary

Construction of the integrated IT system allows not only the elimination of data redundancy and significant error reduction (occurring as a result of repetitive introduction of the same data into the system) as well as implementation of different process configuration based on the complete system analysis.

Decision about the selection of a particular ERP IT system is not an easy one. National industrial enterprises, in the light of information globalization, before the selection of particular IT solution should elaborate the strategic enterprise development and informatization plans.

It is important to determine key requirements and expectations of the final solution at the stage of informatization strategy formulation stage – economic benefits from the implementation of the MRP/ERP system. During the formulation of the requirements it is crucial to have the interest of the whole enterprise in mind, with the exclusion of operational side of currently exploited IT systems (e.g. graphical layout of the reports for the human resources department). User expectations connected with the operational side of the IT system will be processed during the complete system analysis.

The stage of strategic IT development plan should distinguish the strategic systems and select the way of implementation. Therefore the realization of implementation activities based on the IT personnel or ordering part of the works to an external company (outsourcing) is possible. Construction of the system with the use of owned IT resources can be recommended to large enterprises, which ([16], p. 78): have proper knowledge and experience in all areas of system integration, can withstand the considerable cost of long-term global expenses, develop specific informational systems and aim at maintaining the control over the production of strategic applications. Whereas outsourcing is advised to enterprises, which have limited experience in construction and integration of systems and the system itself is not to be a strategic application.

When analyzing the modern trend of integrated system development, it is important to draw one's attention to the software lease method in the Application Service Provision, see ([10], pp. 48–55). Application lease concept is a natural extension of WAN technologies and internet development. In the ASP system the enterprise is granted a 24h access to the software that exceeds the purchasing possibilities of the enterprise in the standard set, exploitation fees are relevant to the application usage, software installation issue is limited only

to proper configuration of internet browsers (e.g. Internet Explorer). Archiving of the data is one of the duties of the ERP package provider. Enterprise can gain significant savings through the reduction of employee number. Software outsourcing in the ASP system can be recommended in case of standard implementations.

Considerable reduction of implementation cost is possible in case of standard solutions for typical areas of enterprise activity (e.g. finance and accounting). In case of highly technologically complex solutions e.g. integration of specific domain subsystems with stan-

dard modules of the ERP package, it seems that the traditional methods of license and IT services selling will dominate.

The key element of the implementation is proper reconstruction of industrial processes performed to optimize work organization methods and material resources flow. Results of complete system analysis of the industrial organization should answer the questions about the restructuring directions, informational needs and decide about the selection of proper functionality and technological architecture of the ERP package.

It is important to see that the mistakes made in the analysis stage will cumulate and usually be detected during trial tests of particular modules, what usually leads to delays and performance of unpredicted changes.

Evaluation of the compromise degree between functionality and change and modification possibilities as well as the necessity to perform restructuring in the enterprise are especially important in the process of construction (implementation) of complex ERP systems. Selection of proper implementation methods of all extensions in the standard software determines the overall quality and flexibility of the final solution, risk and cost of the endeavor as well as other investments required for the maintenance and modernization of the system. Technical aspect of the implementation is equally crucial (e.g. safety and scalability of the system, data integration and ergonomics of the interface). Summing up, it is necessary to state that the selection of proper enterprise IT process integration implementation methodology and technology decides about the success of the investment.

7 References

- [1] Abramowski K. - *Integracja przedsiębiorstwa* [in] Infoman, No. 4, 2000, pp. 30.
- [2] Bazewicz M. - *Metody i techniki reprezentacji wiedzy w projektowaniu systemów*. Wyd. Politechniki Wrocławskiej, Wrocław 1994.
- [3] Bocij P., Chaffey D., Greasley A., Hickie S. - *Business Information Systems. Technology Development and Management*. Pearson Education, Londyn 1999.
- [4] Braa K., Sandahl I. - *Approaches to standardization of documents* [in] Information and process integration in enterprises. Kluwer Academic Press, Boston 1998.

- [5] Bues M. - *Offene Systeme. Strategien, Konzepte und Techniken für das Informationsmanagement*. Springer, Berlin 1994.
- [6] Chmielarz W. - *Systemy informatyczne wspomagające zarządzanie. Aspekt modelowy w budowie systemów*. Dom Wydawniczy "Elipsa", Warszawa, 1996.
- [7] Flakiewicz W. - *Pojęcie informacji w technologii multimedialnej* [in] *Badania Statutowe SGH*, No. 03/S/0018/99, KAE SGH (maszynopis powielony), Warszawa 1999, pp.2-7.
- [8] Goliński J., Mroziak S. - *Strategiczny plan rozwoju zastosowań informatyki podstawą efektywnego zarządzania* [at] IV Ogólnopolska Konferencja nt. Komunikacja miejska. Efektywność transportu zbiorowego w miastach. Izba Gospodarcza Komunikacji Miejskiej, Łódź 2000, pp. 125-148.
- [9] Heng K. - *Enterprise modeling within the Framework of Business process reengineering* [in] *Information and process integration in enterprises*. Kluwer Academic Press, Boston 1998.
- [10] Książ A. - *Obietnice wschodzącego rynku* [in] *PC Kurier*, No. 17, 2000.
- [11] Krupa T. - *Projektowanie strategii informatyzacji* [in] *Przedsiębiorstwo w procesie globalizacji*. WNT, Warszawa 2001, pp. 207-224.
- [12] Lasek M. - *Modele referencyjne struktur procesowych przedsiębiorstw* [in] *Studia Informatyki gospodarczej. Integracja i Architektury systemów informatycznych przedsiębiorstw*. Wyd. WNE Uniwersytetu Warszawskiego, Warszawa 2000, pp. 209.
- [13] Lasek M. - *Integracja w przetwarzaniu informacji gospodarczych* [in] *Informatyka*. Wydanie specjalne, No. 1, 1998.
- [14] Niedzielska E. - *Zintegrowane środowisko zarządzania jako perspektywiczna platforma użytkownika gospodarczych systemów informacyjnych* [in] *Business Information Systems '97*, Poznań 1997.
- [15] Oblój K. - *Strategia organizacji*. PWE, Warszawa 1998.
- [16] Pańkowska M. - *Współdziałanie podmiotów rynku produktów i usług informatycznych*. Wyd. Akademii Ekonomicznej, Katowice 1998.
- [17] Perreault Y., Vlasic T. - *Wdrażając Baan'a IV*. Autorski przewodnik prac przygotowawczych i wdrażania. UCL systemy MRP II S.C., Skiernewice 1998.
- [18] Sakai N. - *Logical Structure Transformation between SGML documents* [in] *Information and process integration in enterprises*. Kluwer Academic Press, Boston 1998, pp. 183-198.
- [19] Wigand R., Picot A., Reichwald R. - *Information, Organization and Management. Expanding Markets and Corporate Boundaries*. John Wiley & Sons, New York 1997.

THE MANAGEMENT METHOD PREVENTING A CRISIS SITUATION IN AN ELECTRICAL ENERGY UTILITY

Krzysztof MAJ*, Tadeusz KRUPA**

*Industrial Electric Power Laboratory
Practical Training Centre, ul. Sportowa 13, 26-670 Pionki
email: kmp@poczta.onet.pl

**Faculty of Management
Warsaw University of Technology, ul. Narbutta 85, 02-524 Warsaw
email: t.krupa@wz.pw.edu.pl

Abstract: The trend observed in the past few years, aiming at raising the level of energy safety both in Poland and in the world, has changed irreversibly the management specificity in the electrical energy industry. Traditional methods of management in this sector began to be insufficient in relation to the present quickly changing reality. The article presents a concept of the management method preventing a crisis situation in an electrical energy utility – a baseload power plant for the risks: a power unit overloading resulting in its disorderly close-down, a lack of technical-economic data transmission and a modification of business data.

Key words: management method, electrical energy utility, baseload power plant, crisis situation, artificial intelligence, Kohonen risk map.

1 Introduction

At present electrical energy belongs to the key products, which are determined with the name of “the products - representatives”. From the economic point of view the quantity of electrical energy production is the measurement of the industrialization of a certain country, its competitiveness on the world markets, determining at the same time the standard of a society’s life. It is impossible to imagine a contemporary economy, which is not based on electrical energy. Electrical energy has a lot of advantages, the most important of which are: an easiness of transformation into other types of energy (mechanical, chemical, radial, thermal), an easiness of transmission to practically unlimited distances, a simple division among customers, an immediate readiness of usage, the purity of processes of its processing and electrical energy transformation, both in industry and household. Other branches and crafts of the national economy are dependent on the energy sector, among which worth mentioning are: the metallurgical industry, the chemical industry, telephony, radio-technology, television, industrial electronics, automatics, robotics, and calculation technology and information technology science – the most strictly connected with the energy sector. Concluding, one may say that there is no branch of life, where the contribution of electrical energy would not be noticed. Assess-

ments in the electrical energy statistics say that 8,3 mln GWh of electrical energy was produced in the world in 1980, 11,7 mln GWh in 1990, 15,0 mln GWh in 2000 and in 2006 over 17 mln GWh of electrical energy was produced. The biggest share in its production belonged to the USA – 23% of the total world production, China – 14,2%, Japan – 5,7%, Russia – 5,5%, India 3,6%, Canada – 3,3%, Germany – 3,2%, France – 3,1%¹.

The share of Poland in the total world production is estimated at approximate 0,82%, which gives it 22nd place in the world. It is important to emphasize that this share for Poland amounted to 1,2% in 1999.

Analysts in the energy branch estimate that in 2020 the demand for electrical energy will reach the value 27 mln GWh. This fact is explained by a dynamic development of the world economy, population growth, a rise in their income and progressive urbanization. A higher demand for electrical energy causes more and more frequently a situation of deficiency in supply of the goods. The problem lies in the impossibility of its storage because this commodity is produced as “in statu nascendi”. More and more crisis situations, which are various in their nature, occur as a result of inadequacy of the rate of demand growth and production possibilities of the plants responsible for the production of this good. These situations violate the

¹ The data come from *CIA World Factbook January 2009*.

energy safety both on the scale of a particular country and of the world.

With regard to such a situation, there appears a problem of a rational energy management related to both its production and usage. As a characteristic feature of electrical energy produced by power plants is a lack of possibility of its storage, therefore power plants producing it at the same time, working simultaneously in The National Power Grid [Krajowy System Elektroenergetyczny (KSE)], which is part of a European grid, have to adjust their load to the changes of the demand on power in this grid. Thus, we may say that on one hand there is a constant forcing of a power plant to work through the demand on energy by its customers connected to power grids and on the other hand, consumers may draw at one time such power as may be produced by power plants. Even an instantaneous cut-off of energy for its customers may cause particular economic loss and therefore a high reliability of the whole grid is required ([2], p.126). The above mentioned power grid consists of entities responsible for electrical energy production (baseload power plants), entities responsible for electrical energy transmission (in Poland the responsible entity is PSE Operator S.A.) and consumers – customers of electrical energy. The operator of the industrial system coordinates a proper functioning of the electrical energy market keeping the balance between the demand and supply.

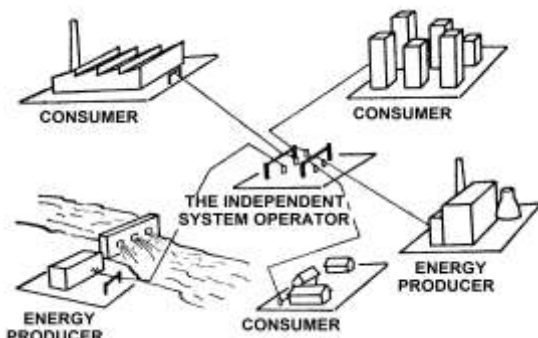

Figure 1. Pictorial model of The National Power Grid

The basic element of technical infrastructure in power plants, being responsible for production of electrical energy are power units. From the economic point of view, turbogenerators processing thermal energy are of the greatest significance in electrical energy grid, and this energy in case of the power plant working in The National Power Grid [KSE], is mainly obtained from burning mineral and brown coal. The percentage share of this type of power plant in production of electrical energy is estimated on the level of 92%. To drive

the turbine of a turbogenerator, water steam is used, which has specified thermo-dynamic parameters and which is generated in steam boilers, which are the elements of electrical energy turbogenerators. Then the kinetic energy in a turbogenerator is processed, owing to electro-magnetic effects, into electrical energy.

The possibility of an uninterrupted transfer of electrical energy between its manufacturers (producers) and customers (consumers), on the assumption that the demand and supply are balanced, at economically justified prices, is a fundamental condition of The National Market of Electrical Energy [KREE- Krajowy Rynek Energii Elektrycznej] functioning. From the point of view of the national economy the changeability of the demand on electrical energy, its immaterial shape, and a lack of possibility of its storage make for the factors causing serious economic repercussions in the energy trade, contributing to substantial fluctuations in prices. Apart from the energy itself, the service of its transmission from producers to customers is a subject of trade on the electrical energy.

2 System of information exchange between the subjects on the electrical energy market and energy safety

The model of the electrical energy market in Poland is presented in Figure 2. Arrows indicate information exchange between its entities.

Groups of entities function on The National Market of Electrical Energy, among which there are the following electrical energy utilities:

- energy producers (professional baseload power plants),
- entities exploiting the transmission power grid (with capacity of 220 kV and 400 kV),
- entities exploiting the distribution power grid (with capacity of 110 kV and lower),
- entities dealing with the energy trade.

With regard to the form of trade, the energy market in Poland is divided into the following types of markets²:

- Contract Market,
- Stock Market,
- Balancing Market,
- Power Exchange.

² You will find further information on the electrical energy market in items [14] i [15] and on the website: www.cire.pl.

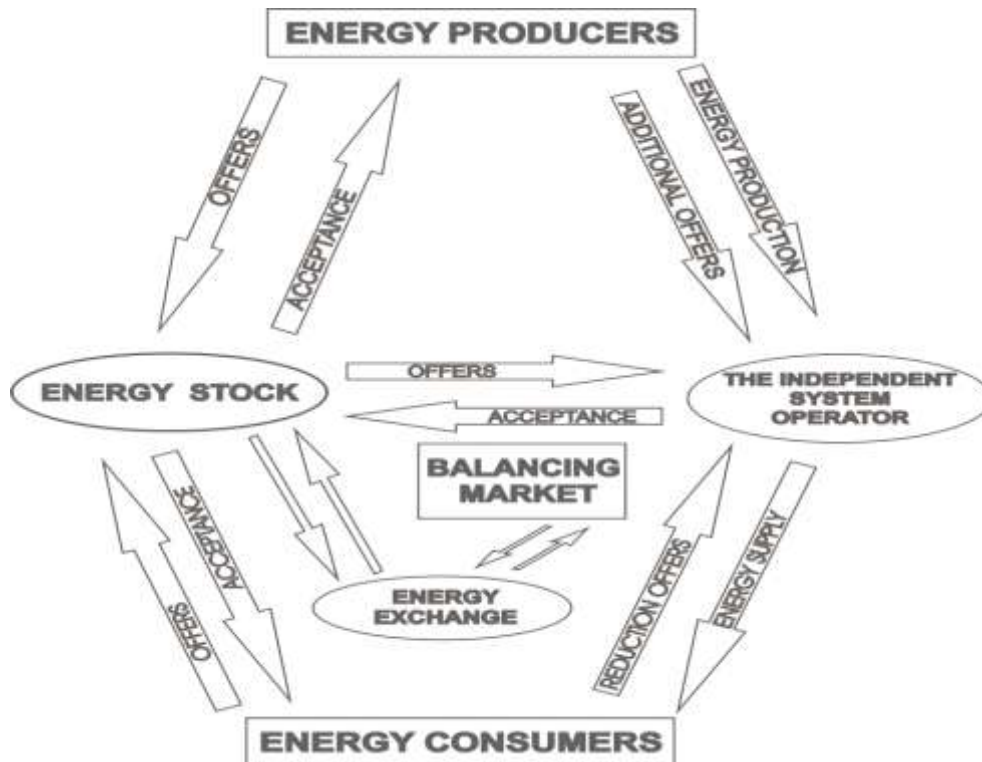

Figure 2. System of information exchange between the entities of the electrical energy market
(source: self study with the use of [15])

An effective functioning of the whole market of electrical energy, consisting in an appropriate balancing of the demand and supply of energy at the maintenance of competition mechanisms, an efficient Exchange of information between the market participants and especially its most important segment – the Balancing Market, is conditioned by the reliability of technical infrastructure, which consist of, apart from hardware, advanced information technology systems: calculation-measuring and telecommunications, being used to exchange data of technical-trading type (e.g. coordination plans, purchase and sales offers and acceptances).

The basic task of information technology solutions for the electrical energy industry is to provide correct and reliable information at the proper time between the participants of The National Market of Electrical Energy. It has been declared that the priority for the projecting and implementing of these information technology systems is the stability of The National Market of Electrical Energy in Poland, as well as integrity of the transmission grid and the reliability of the quality of electrical energy supply, which finally secures energy safety of the whole country.

The correct communication and business information exchange between the participants of the electrical energy market is provided by the Internet, the public

telecommunication network, the cell telephone network and specialized information and communication technology systems allocated exclusively for the electrical energy industry needs, based on dedicated telecommunication channels. Telecommunication services for the needs of the electrical energy industry in the form of outsourcing are dealt with by TEL-Energo S.A. Appropriate security protocols are used for the transmission of trade information. There is a special information technology system used for this purpose, which supports technical and trade processes on the Balancing Market, being an integrated environment of function modules, which support particular functions of the administrator of this system. The factor integrating the environment is the data bases implemented on the basis of RDBS ORACLE 8I and mechanisms of exchange and registration of electronic documents in the file of XML. The Independent System Operator³ [OSP-Operator Systemu Przesyłowego] communicates with the participants of the Balancing Market by two systems of information transmission: The System of Operative Cooperation with Power Plants [pol. SOWE-System Operatywnej Współpracy z Elektrowniami] and The Market Information Exchange [pol. WIRE - Wymiana Informacji Rynku Energii].

³ PSE Operator S.A. - Polish Transmission System Operator.

The System of Operative Cooperation with Power Plants is an essential element of the technical infrastructure of the electrical energy market. This system enables a confidential exchange of technical information between OSP and power plants in the scope of the market control. The other information is transmitted through a separate channel with the use of WIRE system. The solution of SOWE- WIRE provides an opportunity of automatic information and connecting with automatic units control [17]. The solution of the system of information exchange basing on SOWE and WIRE systems is presented in Figure 3.

The exchange of information between applications takes place in the star topology, i.e. communication is possible only between the central server of OSP, regional and local servers in power plants.

It may be stated without hesitation that the basic task of technical solutions for the electrical energy industry, supported by economic-legal instruments, is providing, within a strictly determined time, reliable information

between the participants of The National Market of Electrical Energy.

In the light of the above deliberations, the priority of projecting and implementation of information technology systems is: the stability of The National Power Grid in Poland, integrity of the transmission grid, reliability of the production of electrical energy by power plants and delivery of energy to customers at economically justified prices. The proper implementation of these priorities secures energy safety of the country.

The results of such undertaken actions found their reflection in the document "The Energy Policy of Poland until the Year 2025" accepted by The Ministers Board on 4 January 2005. In this document energy safety is defined as: "the condition of the economy enabling the cover of the current and prospective demand of customers for fuel and energy, in a way technically and economically justified, at minimalization of negative influence of the energy sector on the environment and conditions of the life of society".

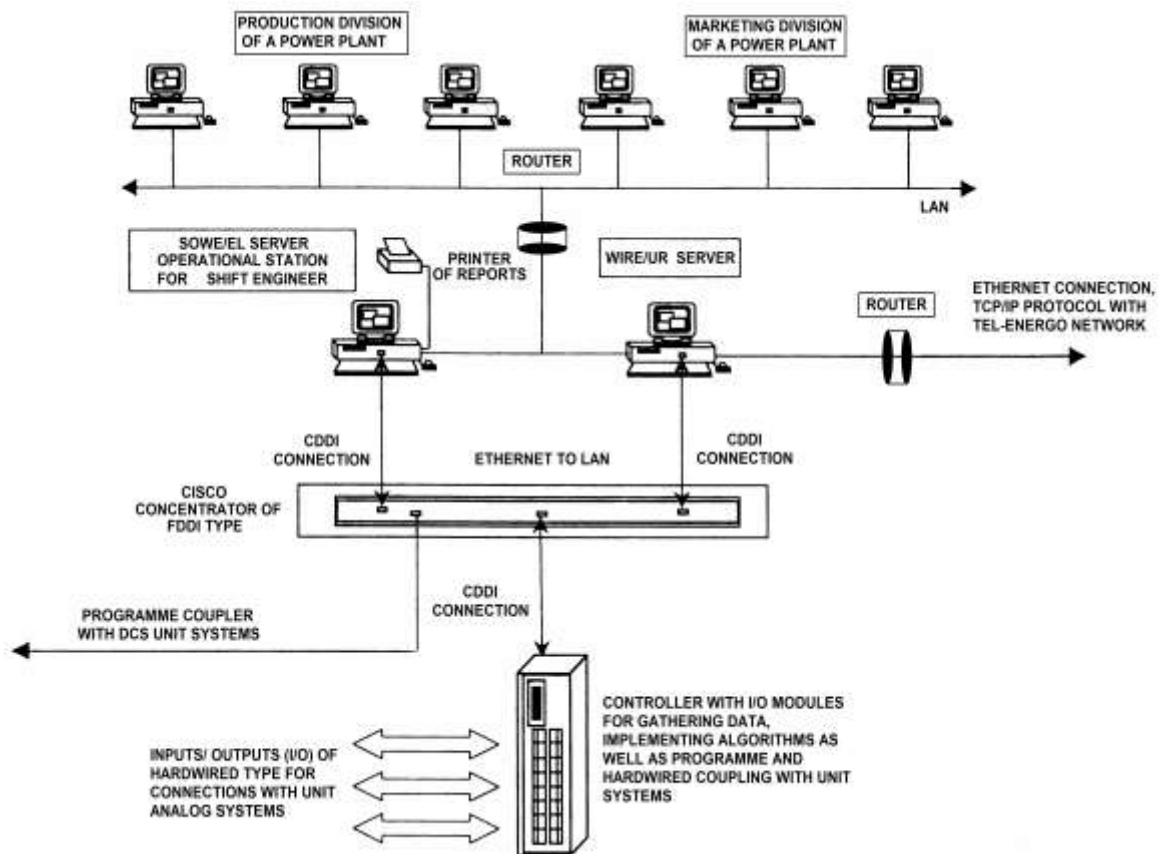

Figure 3. The System of information transmission for the needs of the Energy Market
(source: *Elektrownia „KOZIENICE” S.A.*)

In “technical plane” the safety is defined as the ability of the electrical energy systems to survive of sudden breakdowns, such as short-circuits or unpredicted loss of the system elements, including congestion and the system ability to maintain work of regulating areas joint synchronically and avoidance of occurrence of an uncontrolled division of the synchronic area as the effect of a system breakdown [16].

The reliability of electrical energy supply to customers, which is a derivative of the electrical energy safety, is influenced by the sufficiency understood as the ability of an electrical energy system to supply, on the scale of the whole system, the required quantity of capacity and power to customers, with consideration of the abilities of generating sources, transmission capacity of power grid elements, nodal tensive limitations as well as planned and unplanned elements go-out.

It should be emphasised here that despite the advanced technical solutions and information technology solutions responsible for the correct functioning of the whole the electrical energy system as well as properly oriented state policy, there are a lot of dangers leading to destabilization of the electrical energy market, which directly affect the market entities. For the needs of the article, the considerations will be concentrated around one of the market entities, an electrical energy utility – baseload power plant working in The National Power Grid.

3 Sources of probable crisis situations in an electrical energy utility

In the subject literature a crisis situation is defined as the result of unplanned events interrupting or threatening the normal functioning of a utility [11].

Research of the subject literature and analyses of the biggest grid breakdowns that have existed in the world allow on multi-plane classification of possible crisis situations, at the risk of which electrical energy utilities may occur.

It should be emphasised here that power plants have different vulnerability and susceptibility to possible crisis situations. It cannot be said unambiguously that a specific crisis situation affects all power plants working in the National Power Grid in the same way. With regard to the research conducted in the baseload power plant, further considerations will concern a crisis situation common for a lot of power plants in Poland, caused by the danger of power units overloading resulting in disorderly close-down, a lack of technical-economic data transmission essential for business processes in a utility and a modification of business data.

The risk of different situations occurring in power plants forces them to take new measures aimed at increasing the reliability of electrical energy production. Crisis management has become a process deeply set in the activity of electrical energy utilities, appearing to be insufficient and too expensive for many power plants.

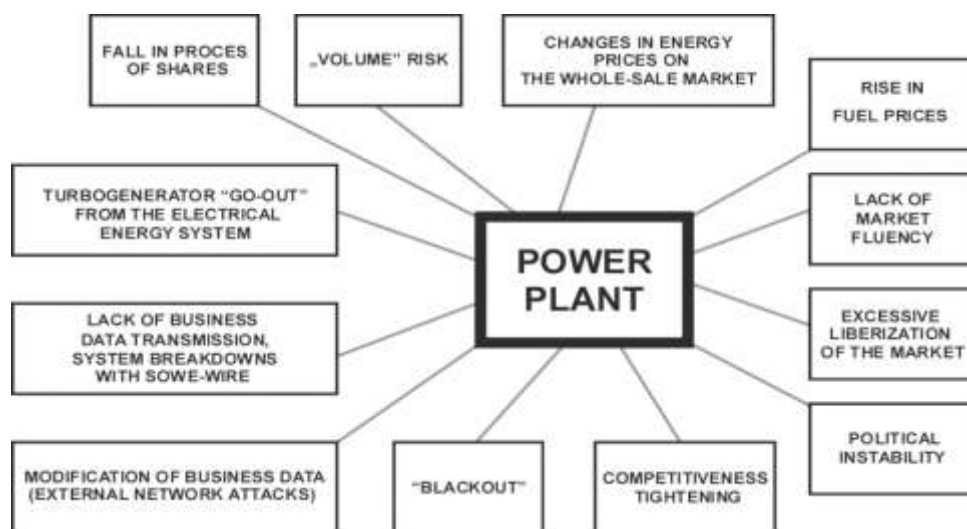

Figure 4. Sources of possible crisis situations
(source: own study with the use of [5])

The burden of actions undertaken should be concentrated on seeking such anti-crisis management methods as would allow foreseeing the symptoms of a coming crisis in time so that it would not escalate. It should be emphasised that interference in the working continuity of the National Power Grid or a substantial part of it makes potentially the most serious interference for the functioning of the technical infrastructure of the country, for which it is difficult to foresee the economic and social effects, which in consequence leads to a violation of the state energy safety.

We may mention here the famous “California Syndrome” (2000/2001), which ended with a breakdown of the electrical energy market in California. The California syndrome (also called purposely a Califor-

nia Lesson) made the decision-makers realize how factors appearing trivial (e.g. a temperature rise, stricter ecological norms, wrong legal regulations) contributed to a lot of events with disastrous effects. As a result of lack of organized actions and methods, aiming at identification of key dangers connected with an existed crisis situation, it led to loss estimated at approximately \$12 milliard.

As the market surveys and analysis of breakdowns in Poland and in the world show, the most disastrous situation for each power plant is a situation of a turbogenerator go-out (go-out of a power unit) from the electrical energy system. A turbogenerator is understood as a set of devices used to generate electrical energy (also called a turbogenerator or a turboset).



Figure 5. The object of study – a turbogenerator (turbogenerator with the capacity of 500 MW) responsible for producing electrical energy⁴
(source: photo by *Elektrownia „KOZIENICE” S.A.*)

⁴ Simplifying, we may accept that a turbogenerator with a steam boiler and the entire necessary technical infrastructure are called a power unit.

4 Economic dimension of a crisis situation as a justification of research on the issue

A turbogenerator go-out from the system may be caused by its purposeful disconnection because of its substantial overloading (action of sets protecting a turbogenerator from its destruction, the so called protection automatics) or on a clear order issued by Power Dispatch Center (pol. Krajowa Dyspozycja Mocy - KDM)⁵. As an example, we may follow the crisis situation that took place on 26 June 2006 in KSE [The National Power Grid] [16]:

„...since the early hours of the morning (around 10:00 a. m.), voltage drops in the transmission and distribution grids had been observed. About 12:00 there were symptoms of danger of voltage maintenance in nodes within the maximum quantity. After 1:00 p. m. sudden events took place, the effects of which caused go-out of turbogenerators from the grid. In Ostrołęka power plant because of a grid overloading at 1:07:57 p.m. the voltage on the switching station buses 110 kV declined to the value of 101 kV, while on the switching station buses 220 kV it decreased to 177,9 kV. At 1:08 p.m. there was a self-activating disconnection of two power units and the cable to Sweden. At 1:00 p.m. in Power Station “Koziernice” the active power of Power Unit no. 7 increased from 218 MW to 224 MW. At 1:09 p.m. there was a self-activating disconnection of the power unit and the turbogenerator. At 1:09 p.m. because of low voltage there was a disconnection of two power units in Białystok thermal-electric power plant. At 1:12 p.m. as a result of the activity of the under-voltage protection, there was a disconnection of three power units in Starachowice thermal-electric power plant and at 1:13 p.m. there was a disconnection of the cable to Sweden. Because of a deficiency of power and very low voltage some customers in north-east Poland were cut off. Crisis situations also affected Warsaw to a great extent. At about 4 p.m. the normal functioning of the transmission system was resumed.”

It is appropriate to raise the economic aspect of the appraisal of crisis situation effects. It should be emphasised that it is the most difficult phase of post-crisis actions. We cannot evaluate unambiguously and precisely the losses that were borne by electrical energy

⁵ The process of a generator switching-off from KSE is described in detail by relevant instructions and procedures, discussion of which goes beyond the subject of the article. An interested reader may find them on websites www.ure.gov.pl, www.pse.pl and [17].

customers because of a disconnection in energy supply. Operator Systemu Przesyłowego [The Independent System Operator] did not balance the energy market properly. Power plants, bound by different contracts and agreements concerning electrical energy sale, did not fulfil those agreements.

We may come across a lot of models in the subject literature, which allow us in a more or less precise way, to evaluate the costs of a past crisis situation. However, these models do not have a universal feature. Too big a number of exogenous variables and the individual character of a crisis situation make the use of these models limited. Knowing a 24 hour schedule of over-loadings of a specified turbogenerator, the price of 1 MWh of produced electrical energy, the day of the week and the season (e. g. a work day, 26th August, the emergency time 24h), simulation studies were conducted, the purpose of which was to project the economic dimensions of the effects of this crisis. For such variables, losses burdened by the power plant only on account of unproduced energy because of a go-out of one power unit with capacity 500 MW, may be evaluated for PLN 1795032⁶. Experts in the electrical energy field estimate that these costs may be even hundreds times higher than the value of unproduced energy⁷.

Literature and factographic analysis reveals a substantial shortage of publications and research in the area of the issue under discussion⁸. On one hand an available subject literature raising the issue of crises situations in utilities (seldom in electrical energy ones) concerns exclusively their economic plane (financial crisis), on the other hand, in available studies and conducted research it was mainly concentrated on models predicting a risk of a crisis situation occurring in utilities without an analysis of the causes of this phenomenon. This research mainly concerned crisis situations,

⁶ All the research and simulation trials were conducted on original measuring data from POWER UNIT 500 MW, of Elektrownia „KOZIERNICE” S.A., by courtesy of the power plant Authorities.

⁷ Gładys H., Matla R. - *Praca elektrowni w SE*, WNT, Warszawa 1999, p. 170.

⁸ After a serious voltage breakdown that took place on 26 June 2006 in KSE, Instytut Automatyki Systemów Energetycznych [The Institute of Energetic Systems Automatics] in Wrocław started research on such types of crisis situations in power plants. However, this research concerned the issues connected with unreliability of technical devices, rather than prediction of crisis situations.

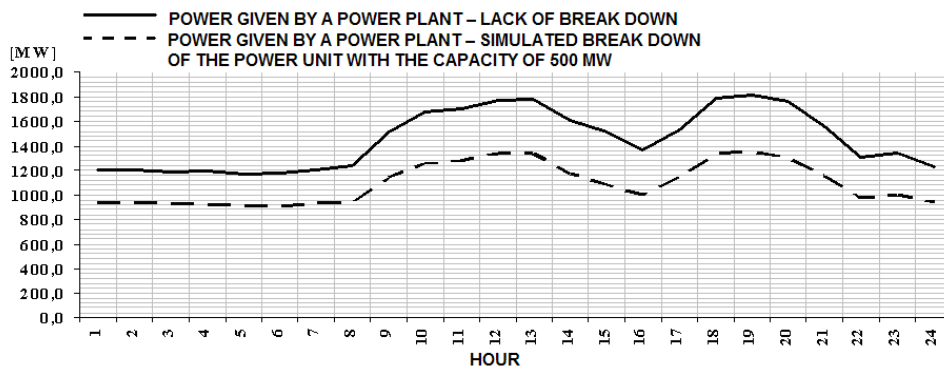

Data: work day, 4th February 2010, price PLN 180.00 for 1 MWh, losses amount to PLN 1558330 (approximately € 378235)

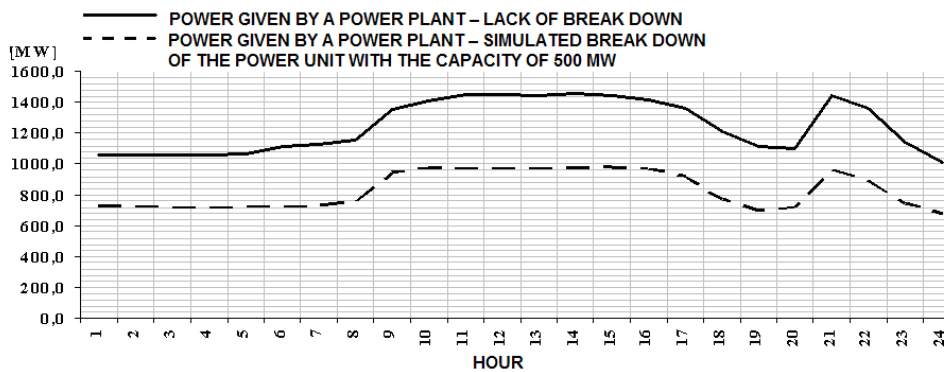

Data: work day, 26 August 2009, price PLN 181.00 for 1 MWh, losses amount to PLN 1795032 (approximately € 435687)

Figure 6. Simulation of a crisis situation, go-out of the power unit 500 MW, for different input parameters – estimation of losses suffered by the power plant (source: self study)

the sources of which were economic perturbations, bad economic situation etc.

We cannot then talk about an effective usefulness of these studies to solve the issue. A serious impediment in making decisions in the conditions of a crisis situation is a shortage of applicative dimensions of research. Such a condition causes that even well elaborated models are not adequate tools in supporting a management decision in the phases of predicting crisis situations in electrical energy utilities.

On the basis on literature and factographic analysis, related to the state of knowledge in the scope of the issue, we may form the following conclusion, supporting the purposefulness of continuing research in this field:

- professional the electrical energy industry in Poland begins to face requirements difficult to fulfil, which

go beyond its current technical and economic opportunities,

- there exist a lot of dangers of the destabilization of the electrical energy market, which create a big risk of activity towards the market entities; these dangers usually lead to crisis situations,
- we may suppose that crises situations will take place in electrical energy utilities with a higher frequency than before⁹,
- the problem of crisis situations occurring in the electrical energy industry and an appropriate approach to it, in the sphere of a crisis management is a new issue, which was revealed at the moment

⁹ The cause of it is outdated apparatus and automatics directing the work of power units. It is also a result of outdated technologies used in power plants, unmodernized distribution stations and a shortage of financial means for new grid and productive investments.

of the biggest grid breakdowns, observed in the last ten years both in the world and in Poland,

- classical systems of “protection in the event of a crisis situation occurrence”, in the light of the contemporary reality, are out of date and are not relevant to the quickly changing circumstances¹⁰,
- there is a shortage of scientific publications on the prediction of crisis situations with regard to classical “coal-fired power plants”,
- the problem of the prediction of crisis situations in baseload power plants provokes a great interest among managerial personnel and in professional engineering environments of the electrical energy branch,
- up to the present time, no scientific method of management has been elaborated, which would identify and diagnose symptoms of a future crisis in a professional baseload power plant, and which would concern making decisions in the danger fields discussed in the article.

In the light of the above studies there appears to be an unsolved serious problem for power plants:

“How, in the light of measures undertaken, aimed at securing the electrical energy safety of the country, at certain limitation, may a crisis situation be predicted and what decisions should be made on the operational level to avoid the effects of a future crisis?”.

5 The usage of artificial intelligence methods to predict a crisis situation in an electrical energy utility

5.1 Concept of the problem solving

The solution to such formed research problem is a management method based on predicting a crisis situation in a power plant, which uses process modeling

¹⁰ As an example, we may give a set of procedures in the event of a crisis situation presented on page 104 in Instruction on Transmission Grid Movement and Exploitation (elaborated by Polish Electrical energy Grids Joint-stock Company). Item 5.2.5.2 speaks about the procedure in the situation of the system breakdown, as follows: “...work of turbogenerators should be kept according to the strictly defined procedure of The Independent System Operator of telephone orders or within the so-called tele-orders system”. As the reality showed, the tele-orders system during the breakdown of 26 June 2006 appeared completely useless and even erroneous for the personnel of power units operation in some power plants (Kozienice, Połaniec, Bełchatów).

based on the technique of the artificial neural network. This method contains an important feature of the neural network, which is an ability to predict time series, which found an application in predicting overloading, within which critical overloadings that have a destructive influence on the work of turbogenerators. It should be emphasised that the prediction of future values of the critical power is a significant factor of the process of decision-making by the engineer personnel, in the situation of a coming crisis.

In the effect of applied integrated techniques of the artificial intelligence, appropriate neural models were built, which were predictors of a crisis situation in a power plant. The proposed method allows the engineer personnel to make certain preventive organization actions in a baseload power plant, where a crisis situation is generated by three types of danger:

- overloading of a turbogenerator resulting in a disorderly close-down of the power unit,
- lack of technical-economic data transmission, essential to implement business processes in a utility,
- modification of business data.

The starting point to create the method was to specify the key business areas of the utility covered by the effects of the above mentioned dangers and to gather essential measurement data, which are important for the examined phenomena. Such actions allowed on the implementation of the method into the information architecture of a power plant.

This structure consists of three basic levels:

- the level of information gain,
- the level of information processing,
- the level of making decisions by the administration on the basis of the processed information.

On the level of information processing, with the use of inner LAN in a power plant, the data of the work of the turbosets are transmitted through the Intranet network or special dedicated channels to the main server of the system, where decisions are made, regarding the work and functioning of the power units in a power plant.

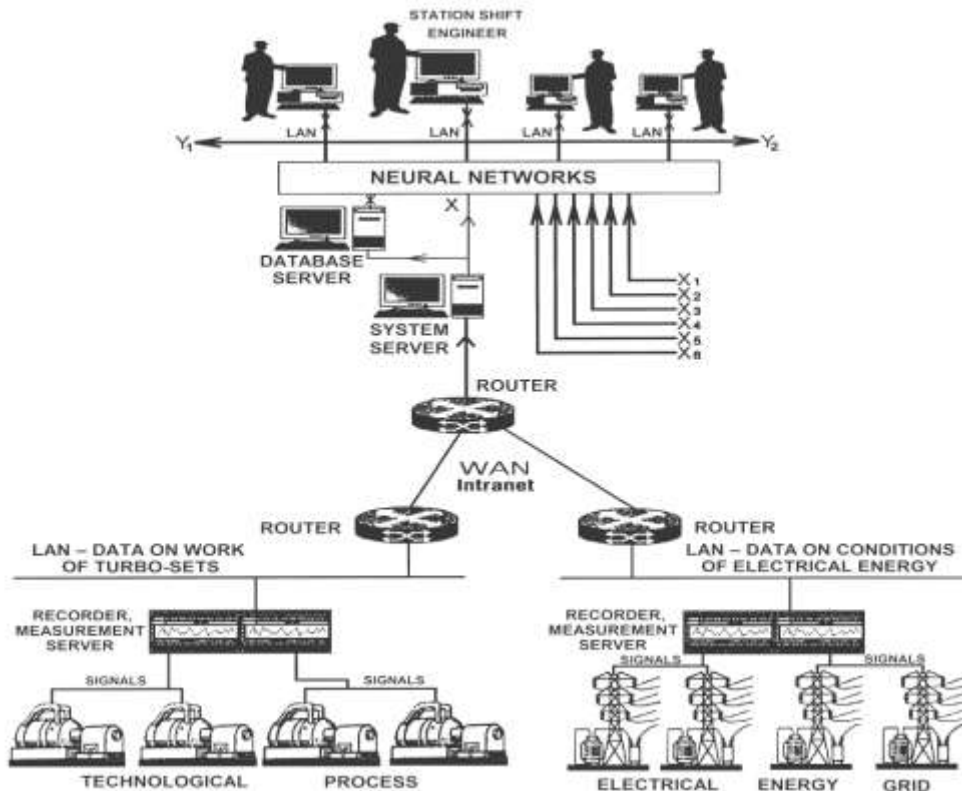

Figure 7. Implementation of the management method, used to predict a crisis situation, into the architecture of the information system of a power plant
(source: self study)

Through the medium of the Intranet network or dedicated telecommunication channels, the server also receives technical data on the condition of the power grid as well as the data concerning the demand on electric power from electrical energy customers. These are data with a great significance to plan the work of turbosets – units responsible for generating power and supplying it to the whole electrical energy system.

The values X_1, \dots, X_6 are the information delivered to the input of the neural network from the environment, which is really important for the administration to make decisions referring to the functioning of the system. All the information in the form of numerical sequences goes to the level, where it is analysed and processed by neural networks. The information in the form of files with data is gathered and saved on a special server – database, which plays an important part as it is the source of the training data used to teach the neural networks. The information processed by the neural network is transmitted through LAN directly to the management personnel responsible for making decisions. This information may be accepted by the administration or rejected.

The accepted information is used to make particular decisions having an essential meaning for further functioning of the system, which was marked in the diagram as the input data Y_1 and Y_2 (responses). If the management personnel do not accept the signals directed from the level processing information, these signals are directed to another analysis (e.g. further search for optimal solutions) or they are totally rejected as unimportant to make a decision. In this case, the neural network fulfils a role of “an adviser – expert” basing on the experience (the data from the past) and predicting future events with a high probability of their occurrence.

Finally, it should be added that the transmission of information in the form of numerical data takes place on the basis of the classical TCP/IP protocol and it provides an opportunity of the access to the data saved in the standard form as well as to the measurement data placed in the form of files with a historical character on the FTP server – the database (the so-called “historian server”).

5.2 Gaining and selecting the input data

The basic source of information, on which the research and the method were based, was a collection of approximately 1 million of historic measurement data. These were data concerning net 24-hour production of active power, gathered from POWER UNIT of 500 MW of Power Station „KOZIENICE”. This data was received from the measurement database saved over the period from January 2002 to January 2010. In the light of such a numerous collection of measurement data, there appeared a problem of their redundancy, which especially at the beginning violated the process of the network training. Therefore, an important phase before starting the due research, was a process of preparing relevant data, the so-called pre-processing, consisting of selection, extraction, cleaning, transformation and supplementation of a possible deficiency in the data sequences.

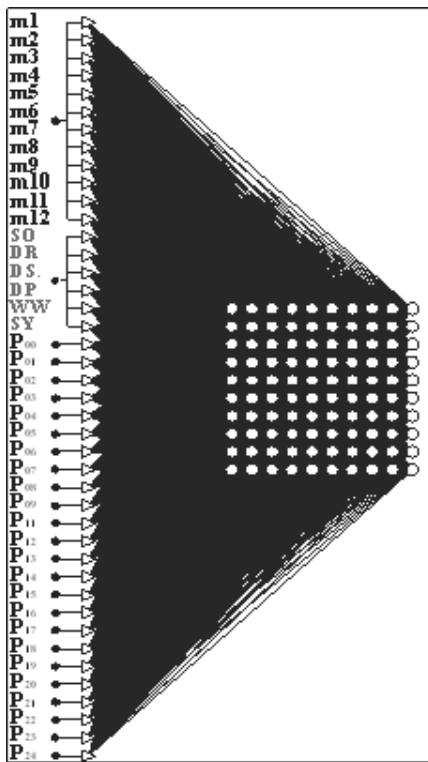

Figure 8. Kohonen model with appropriate power inputs
(source: self study)

In this way representative data were prepared, which manifested specific crisis situations, and owing to it an extraction of factors responsible for the crisis situations was done. In this way input variables, being essential to build a neural model, were specified.

The basic input variables were variables with quantitative and qualitative characters. The power input vector

contained variables specifying the month, the particular day of the week as well as the variable specifying the active power produced by a power plant within a given measuring hour - h. It became essential to apply a binary coding (marking 0 or 1) of each of from n1 to n dimensions of the input vector. These actions led finally to the creation of a reliable Kohonen map, in which an appropriate profile of 24h turbogenerator overloading was assigned to each network cluster.

Supplementary data, having a significant meaning for a map created in this way, consisted of endogenous variables with a categorized character, to which particular dimensions of the input vector were assigned. Previously mentioned “markering” of the binary type of appropriate inputs of the neural network was applied to these input variables.

The dimensions of Kohonen map were specified arbitrarily through experiments, with consideration of the special network abilities to make generalization. In this way a risk map came into being, created by the self-organizing map of Kohonen features.

A set of pattern vectors was obtained, which characterized 24h overloading profiles of a turbogenerator of a power unit with the capacity of 500 MW, in different states and conditions of the environment (with consideration of the work of a power unit in the conditions of interruptions and an occurrence of a crisis situation). A specified work condition of a turbogenerator (the so-called profile of 24h overloading of a turbogenerator) was assigned to each network cluster. The areas of the so-called forbidden work were obtained on the map, i.e. work being generated by crisis situations.

An application of the neural model (Kohonen map) allowed on the comparison process of the pattern vectors (profile overloadings) with the control vector, being a profile vector built on the basis of the last correct transmission of the data essential to implement the business processes. An assignment of the entire 24h profile of a turbogenerator to an appropriate neural network cluster is done in this process.

The content of each of the model sets undergoes a comparison process by Kohonen network with the real set of data, which represents the current work condition of the device with the above mentioned control vector. As a result of the comparison of the pattern set with the real set, one of the neurons is activated (the so-called neuron “the winner”). This takes place when appropriate characteristics are “fit” to each other. An analysis of the location of the work points on the

risk map allows the management personnel to control the conditions which may lead to a crisis situation (especially an overloading of a power unit).

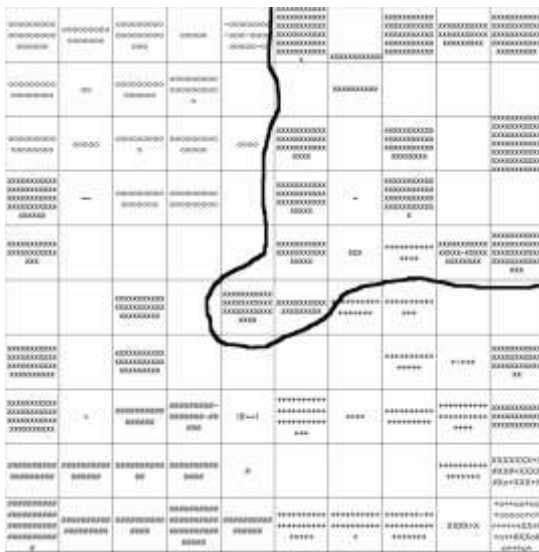

Figure 9. Set of model vectors in the form of Kohonen map (risk map), with the marked area of forbidden work of a turbogenerator (source: self study)

In the Figure 10 points 1, 2, 3 indicate the localization of profile vectors in clusters of the map, respectively for 24h overloading in time intervals D-1, D-2, D-3, the existed situation and the graph direction indicate a possibility of work in the forbidden area.

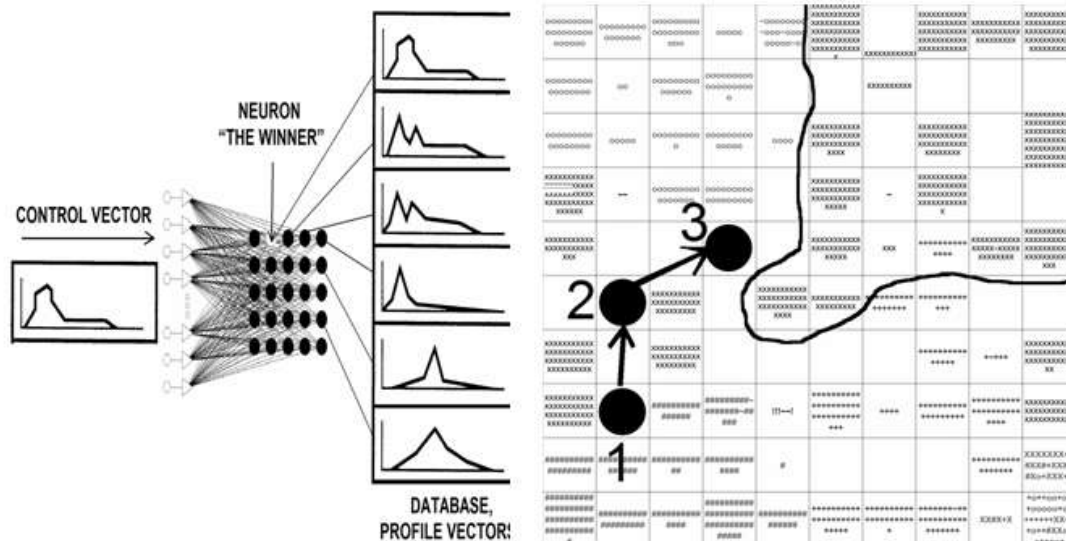

Figure 10. The activation of networks with the help of the control vector – comparison process, where the profile vector is being assigned to an appropriate network cluster – the risk map (source: self study)

In this phase of the method, correctness verification of the transmission stream of the data takes place as well as detection of the modified data (the control vector does not fit any pattern characteristics). In this way a crisis situation in a power plant is eliminated, which would be caused by a purposeful modification of technical-economic data essential to implement business processes. In this case Kohonen network plays the role of a data discriminator.

The next important phase of the experiment was to build neural models, predictors of critical overloadings of a turbogenerator. Three types of the neural network were tested with the use of different forms of the input vector and different structures and methods of teaching the network (MLP, RBF, GRNN). The input vector contained 16 variables with changing quantitative and qualitative characters. The input variable took a quantitative value and returned the result of a time series prognosis one-hour in advance (h+1).

However, the research assumption was that the network would generate a prognosis at the output 24 hours in advance. So it should be assumed that prognosing the next values of the prognosed time series (h+2), (h+3) ... to (h+24) is done through an introduction of the values prognosed in the previous steps to the network inputs.

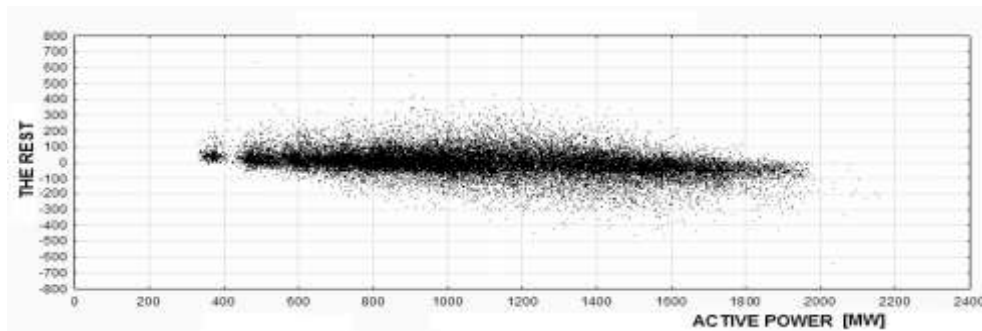

Figure 11. Diagram of the rests for RBF network – the best built model with the parameters of: aberration quotient of 0,19 correlation of 0,98 MAPE error of 4,7%
(source: self study)

24 digits, being a series of the prognosed values of overloading in specified hours, were obtained at the output. It should be emphasised here that redundancy in the dimensions of the input vector increased the number of weights in the network, which affected the process of teaching the network.

As the research showed, this phase of the method contributes to the quality of the prognosis to the greatest extent. In the light of the studies and experiments with the use of the artificial neural networks, we may say, that the most important factor deciding upon the quality of the neural models (the smallest errors, time of teaching, a number of iterations necessary to train the network) is the quality of the data used to the process of teaching the network. Another important factor is an appropriate representative trial of the teaching data (redundancy specified arbitrarily). Therefore it was necessary to prepare an appropriately numerous set of the redundant data. In this way a broad spectrum of the teaching data was obtained, which contained multiple repetitions of similar patterns and which manifested specified phenomena, within which the symptoms of a crisis situation.

In the final phase of the method, a critical turbogenerator overloading started to be prognosed with the use of neural models generating a crisis situation.

It is worth emphasising that the elimination of untypical variables from the teaching set improved the model quality (decrease in MAPE error to approximately 2,5%), yet on the other hand, there was an increasing danger of a loss of the complete spectrum of the teaching data which manifested different conditions of the work of a power unit, within which the symptoms of a crisis situation. Therefore the error on the level of 4,7% was recognized as satisfactory.

6 Summary and final conclusions

Application of the anti-crisis actions with the use of the discussed method allowed a decrease of 82 % of the losses, which a power plant would bear in the effect of no application of any preventive actions. These losses, first of all, result from unbalanced demand and supply of electrical energy. A choice of artificial neural networks as a research tool was dictated, in the first place, by all the possibilities, which these “sophisticated techniques” entail. Because of non-linearity of dependencies, multidimensional input vectors, multiple character of some relations between exogenous and endogenous variables, a lack of bases to linear approximation of phenomena and processes as it takes place in case of process modelling in the electrical energy industry, application of neural networks that can map non-linear dependencies is deeply justified. Accepting such an assumption and its application in the presented management method led to a solution of the research problem mentioned previously.

In this method a very important feature of neural networks was used, which is the ability to predict time series data, which found its use in prediction of overloadings, within which, overloadings of critical turbogenerators. Prediction of future values of power is a significant factor in the decision-making process preventing crisis situations. This method is an alternative one when an electrical energy utility finds itself in a situation of impending crisis. It allows the engineer personnel (Station Shift Engineer) to undertake a lot of organization actions, among which, they may use an early switching-off of the power unit, even being in the state of the so-called “cold reserve”. As the research – movement trials showed- the average time required to put such a power unit into full operation amounts only to 40 minutes. The second important

organization action, which may be undertaken by the management personnel, is a simultaneous switching-on of another, additional relieving power unit for the time of a crisis situation, which as the previous research shows, could be predicted with the use of the proposed method. The third important solution, which may be applied owing to this method, is relieving a power unit of the parent power plant through pre-planned putting an additional power unit in another power plant into operation (planned switching-on of the spinning reserve).

The research conducted with the use of the artificial intelligence techniques appeared to be very promising. On the basis of the research and experiments conducted an application in the language C++ has been created, with the name ACM-2010, and it has been implemented in the real conditions of the work of power plants. It will allow the management personnel to select specified organization actions preventing a crisis situation in an electrical energy utility.

The authors hope that laborious long-term research will contribute, at least to a little degree, to overturn a myth existing in engineering environments, which says that the science and the industry have not elaborated satisfactory methods of appropriate cooperation yet.

7 References

- [1] Barton R.M. - *Crisis Management*. Oxford Press Publishers, Oxford 1993.
- [2] Górczyński J., Urbaniec K. - *Wytwarzanie i użytkowanie energii w przemyśle*. Oficyna Wydawnicza Politechniki Warszawskiej, Warszawa 2000.
- [3] Helt P., Parol M., Piotrowski P. - *Metody sztucznej inteligencji w elektroenergetyce*. Oficyna Wydawnicza Politechniki Warszawskiej, Warszawa 2000.
- [4] Kalyvas E. - *Using neural networks and genetic algorithms to predict stock market returns*. Department Of Information technology Science, University Of Manchester, Manchester 2001.
- [5] Lelątko P., Michalski D. - *Zarządzanie ryzykiem na rynku energii elektrycznej*. Instytut Doskonalenia Wiedzy o Rynku Energii, Warszawa 2004, pp.167-246.
- [6] Maj K. - *Informatyka w energetyce- przykłady zastosowań i funkcjonowania systemów informacyjnych w wybranych segmentach Rynku Energii Elektrycznej w Polsce*. Zeszyty Naukowe Nauki Ekonomiczne Nr 33, Politechnika Świętokrzyska, Kielce 2005.
- [7] Maj K. - *Możliwości zastosowania sieci neuronowych w przewidywaniu sytuacji kryzysowej w przedsiębiorstwie elektroenergetycznym*. Zeszyty Naukowe Nauki Ekonomiczne Nr 35, Politechnika Świętokrzyska, Kielce 2007.
- [8] Maj K. - *Możliwości zastosowania sieci neuronowych w Systemach Wczesnego Ostrzegania - jako narzędzia wspomagającego procesy zarządzania w energetyce*. Zeszyty Naukowe Nauki Ekonomiczne Nr 34, Politechnika Świętokrzyska, Kielce 2006.
- [9] Malko J. - *Wybrane zagadnienia prognozowania w elektroenergetyce*. Oficyna Wydawnicza Politechniki Wrocławskiej, Wrocław 1995.
- [10] Mitchell M. - *An introduction to genetic algorithms*. MIT Press, Cambridge 1997.
- [11] Oldcorn R. - *Management*. London MacMillan 1989.
- [12] Osowski S. - *Sieci neuronowe do przetwarzania informacji*. Oficyna Wydawnicza Politechniki Warszawskiej, Warszawa 2000.
- [13] Siwek K. - *Prognozowanie obciążeń w systemie elektroenergetycznym przy wykorzystaniu sztucznych sieci neuronowych*. rozprawa doktorska, Wydział Elektryczny Politechniki Warszawskiej, Warszawa 2001.
- [14] Weron A. - *Gielda Electrical - strategie zarządzania ryzykiem*. CIRE, Wrocław 2000.
- [15] Zerka M. - *Mechanizmy rynkowe w elektroenergetyce - zagadnienia wybrane*. Instytut Doskonalenia Wiedzy o Rynku Energii, Warszawa 2001.
- [16] *Raport Końcowy z prac Zespołu ds. Analizy Zakłóceń w Systemie Elektro-energetycznym w 2006 roku*. Departament Energetyki Ministerstwa Gospodarki, Warszawa 2006.
- [17] *Raport na temat stanu zagrożenia ciągłości pracy krajowego systemu elektro-energetycznego w Polsce*. Departament Usług Operatorskich, Polskie Sieci Elektro-energetyczne S.A., Warszawa 2006.

THE MULTICRITERIA SELECTION METHODOLOGY OF THE DECISION SUPPORT SYSTEM

Justyna PATALAS-MALISZEWSKA*, Tadeusz KRUPA**

Faculty of Mechanical Engineering

University of Zielona Góra, 65-417 Zielona Góra, Poland

email: j.patalas@iizp.uz.zgora.pl

Faculty of Management

Warsaw University of Technology, 02-524 Warszawa, Poland

email: t.krupa@wz.pw.edu.pl

Abstract: An issue of building a tool orientated to the support of selection process of decision support system (DSS) for the sector of small and medium enterprises is presented in the article. A group method of data handling (GMDH) whose application allows to objectives a search process of required DSS, with assumed costs and other existing resource limitations, is proposed for this purpose. The article is devoted to a problem of GMDH adjustment to solving the tasks related to the selection of a required system from among the information systems of DSS class, according to the criteria determined by a future user of this system. The GMDH takes into account among other things such assumptions as: a precise description of dependences between input and output data in a specified time horizon, independence of the user's knowledge (the values of observed data from the past registered in the base are the input data) and minimization of modelling errors (the selection of solutions takes place by means of a selected evaluation rule of quality estimation).

Keywords: Decision support system (DSS), multi-criteria decision making model, group method of data handling (GMDH), information system of GMDH class, neuronal networks, genetic algorithms, root mean squared error of approximation, Iwachnienko polynomial, polynomial decision making model, SME sector.

1 Introduction

The decision support systems (DSS) are based on making use of various analytic, logic, statistic and heuristic optimization models and methods. A field of DSS applications includes a wide spectrum of decision making problems which exist in the surroundings. In other words, only technical conditions and a scope (accessibility) of the knowledge on a subject of specified fragment of reality determine a possibility of building a selection support system, dedicated to specified applications, and implementing an appropriate DSS.

A decision related to the DSS selection and implementation is usually based on a forecast of potential benefits resulting from its use in an enterprise [7]. However, a definite market niche for the tools oriented to the support of DSS selection and implementation process, useful in the conditions of a given enterprise, can be noticed here.

The problem boils down to finding a tool oriented to the support of DSS selection process for the enterprise. Building a multi-criteria decision making model, using a GMDH, means a possibility of objectivising a search process of appropriate DSS, with assumed costs and

other existing resource limitations. A theoretical and apparatus background prepared in the form of information system which includes an operation methodology and utility program packet intended for carrying out simulation experiments in a preparation and selection process of optimum variant of decision plays an essential role in the DSS selection and its later application.

A GMDH (Group Method of Data Handling) can be applied to the selection of information system of DSS class on condition of appropriate adjustment of the system of this universal method to the specificity of DSS and their concrete applications.

In the article the GMDH (see point 2) is described in detail and it is shown that it can be a tool for building a multi-criteria model of DSS information system selection for the enterprise indeed. A polynomial decision making model of DSS selection which includes characteristics of these systems applied in the enterprise is prepared. A description of the model is included in point 3., however, point 4. covers a description of procedure related to the determination of polynomial decision making model of DSS selection. Directions of further researches are presented in the summary.

2 Group method of data handling (GMDH) as modelling algorithm

There is a need of joint optimization of many parameters in decision making processes met in practice. Against a background of the data described in the references and having a practical application, the most often applied data of decision modelling and preparation tools include: artificial neuronal networks, decision making trees and rules and genetic algorithms.

The artificial neuronal networks are used first of all to detect characteristic features of input data, detect concentrations of input data and data compression. These networks are also used as a diagnostic tool because they do not require to be supervised when training. However, a collection of unique training data is often very difficult or it is simply impossible and then it is necessary to select a neuronal classifier based on the networks without supervision. The networks without supervision are submitted to the competitive training. The complete information on a presented input image is sent to each of processing elements of the network. Only this processing element whose vector of weights is similar to the most degree to the input vector is subject to the activation.

Standardized training vectors are applied to the networks' training. Training takes place according to a modified Grossberg-Kohonen rule and belongs to a variety of WTA (Winner Takes All). The modification lies in the fact that the activation of weights in every training step relates not only to a winning neuron but to all neurons being neighbours with it as well. At the start of training, all weights assume random and small values. An input vector activates a competition of the neurons. The winner updates its weights and allows the neurons from the neighbourhood to update the weights [10, 6].

The decision making trees and rules find an application when dividing a set of objects into subsets in such a way until their homogeneity with regard to the affinity to the classes is achieved. It is built a tree whose a hierarchic structure represents a decision making process in order to execute divisions of the set on the basis of variability scope of statistic features describing the objects (explained, dependent, forecast variables, variables describing the affinity). If a variable is of quantitative character then it is build a tree to explain a variable forming process (regressive tree). If a variable is of qualitative character then it is created

a classification tree (a tree representing a division process of a set of objects into homogeneous classes. Its internal nodes describe a way of execution of this division – on the basis of values of the objects' features, and the leaves of the tree correspond with the classes to which the objects belong. And the edges of the tree represent the values of features on the basis of which a division is executed) [4].

The genetic algorithms (GA) enable to search for solutions in parallel in many points of decision making space. There is a possibility of simultaneous identification of many local optima in a set-handling process or ordered images of data by means of genetic algorithms. The genetic algorithms conduct searches, coming not from a single point but from a certain population, use the selection rules probabilistically and not deterministically [2]. The genetic algorithms require to code a set of parameters of the optimization task in the form of finite character string known as a genetic chain. The selection of solution is based on the random rules of crossing, mutation and multiplication and on the functions evaluating an adjustment process of population elements, for example, on the basis of minimization of squared deviation error.

The group method of data handling (GMDH) is an example of solution within the scope of inductive methods¹. It takes into account among other things such assumptions as:

- A precise description of dependences between input and output data in a specified time horizon (random association),
A typology of connections is determined by means of evaluation criterion of quality estimation², however, its training lies in the calculations of weights of connections by means of least squares method³:
- Independence of theoretic knowledge (the values of observed data from the past registered in the base are the input data).

¹ Inductive methods – reasoning on the basis of empirical data [Farlow S.J. (Ed.), 1984].

² Estimation – assessment of the value of given parameter with a specified level of trust [Tadeusiewicz R., 1993].

³ Least Squares Method – a result of next measure y_j can be presented as a sum of (unknown) value measured x and measure error ε_j , $y_j = x + \varepsilon_j$. From the value ε_j we expect so that a sum of squares is as least as possible [Farlow S.J., 1984]:

$$\sum_j \varepsilon_j^2 = \sum_j (x - y_j)^2 = \min$$

Table 1. The financial parameters of SME sector enterprise
(source: self study)

Period (the data from financial documentation on)	Income	Sales	Payables
30.06.2005	340 thousand	280 thousand	2 900 thousand
31.12.2006	383 thousand	313 thousand	3 145 thousand
30.06.2007	580 thousand	476 thousand	2 100 thousand
31.10.2008	620 thousand	520 thousand	2 500 thousand

In a general case, all points being in the data space are a subject matter of the consideration. However, it is beneficial to limit a domain to a subset of observations not including redundant information.

- Minimization of modelling errors (the selection of the most approximating polynomials takes place by means of a selected evaluation rule of quality estimation).

It is of importance to select a concrete formula of external criterion. One of them is a criterion of regularity defined as a root mean squared error of approximation calculated for the data not used to determine the values of parameters of partial model (see (6), [5]).

Let's consider an example illustrating an application of GMDH.

A structural identification of decision making model of information system selection for the enterprise A by means of GMDH allows to estimate economical effects of implementation of this system. For this purpose the characteristics of financial parameters of the enterprise within a 2-year period (covering a pre-implementation period as well as a period after the implementation of information system in the enterprise – see Table 1) are audited.

Assuming that a model representing an initial variable of the object (enabling to evaluate a level of implementation effectiveness of information system with respect to finance) is searched for, the following functional dependence can be postulated:

$$Y = f(X_1, X_2) + e \quad (1)$$

where:

Y – income value in the enterprise,
 x_1 – sales value in the enterprise on 30.06.2005, 31.12.2006, 30.06.2007, 31.10.2008,
 x_2 – payables value in the enterprise on 30.06.2005, 31.12.2006, 30.06.2007, 31.10.2008,

e – error caused by existence of inaccessible disturbances in terms of measurements, it is an independent random variable, where $E(e) = 0$ and $Var(e) = \delta^2 < \infty$, therefore this value is omitted in further calculations.

A designation of the object's structure by means of GMDH algorithm lies in an iterative (step) repetition of determined sequence of operations leading to an evolutionary resultant structure⁴. This process is finished when the value r_j^2 stops decreasing (optimum degree of polynomial complexity is achieved).

In order to determine a population of polynomials (4) for the object with m inputs x_1, x_2, \dots, x_m and one output y it is created a matrix of the following form:

$$X = \begin{bmatrix} X_{11}, X_{12}, \dots, X_{1m} \\ X_{21}, X_{22}, \dots, X_{2m} \\ \dots \\ X_{t1}, X_{t2}, \dots, X_{tm} \\ \dots \\ X_{n1}, X_{n2}, \dots, X_{nm} \end{bmatrix} \quad (2)$$

in which the columns 1 ... m represent independent variables x_1, x_2, \dots, x_m .

In the case under consideration we receive:

$$X = \begin{bmatrix} 1, & 280, & 2900 \\ 1, & 313, & 3145 \\ 1, & 476, & 2100 \\ 1, & 520, & 2500 \end{bmatrix}$$

and a vector y of output values:

$$y = [y_1, y_2, \dots, y_t, \dots, y_n]^T$$

$$y = [340, 383, 580, 620]^T$$

It is assumed that the matrix columns X are linearly independent.

⁴ Evolutionary resultant structure – a set of parameters of a given object, algorithmic equivalent of genotype (set of genes of a given individual) [Goldberg D.E., 1995].

Table 2. The test data for the partials models
(source: self study)

Period (the data from financial documentation on)	Income	Sales	Payables
31.12.2008	630 thousand	580 thousand	2 500 thousand
30.06.2009	620 thousand	560 thousand	2 700 thousand
31.12.2009	600 thousand	520 thousand	2 700 thousand

The input data are divided into training data and test data in this way that:

$$\begin{array}{c|c}
 \begin{array}{c} y_1 \\ y_2 \\ \dots \\ y_t \\ \dots \\ y_n \end{array} & \begin{array}{c} x_{11}, x_{12}, \dots, x_{1m} \\ x_{21}, x_{22}, \dots, x_{2m} \\ \dots \\ x_{t1}, x_{t2}, \dots, x_{tm} \\ \dots \\ x_{n1}, x_{n2}, \dots, x_{nm} \end{array} \\
 \hline & \text{division line}
 \end{array} \quad (3)$$

A division line divides a matrix (3) into the training data (1, 2, ... t) and test data (t+1, ... n). The training data shall be used to construct a model of the object, however, the test data shall be used to evaluate the partial models. The data as the test data are assumed in table 2.

$$\begin{array}{c} Y \\ \left[\begin{array}{c} 630 \\ 620 \\ 600 \end{array} \right] \end{array} \quad \begin{array}{c} X \\ \left[\begin{array}{c} 1, 580, 2500 \\ 1, 560, 2700 \\ 1, 520, 2700 \end{array} \right] \end{array}$$

In the first step, for each pair of independent variables $\langle x_p, x_q \rangle$, $p = 1, 2, \dots, m-1$, $q = p+1, \dots, m$ it is created a approximating polynomial in a general form:

$$\begin{aligned}
 y^* &= A_{pq} + B_{pq}x_p + C_{pq}x_q + D_{pq}x_p^2 \\
 &+ E_{pq}x_q^2 + F_{pq}x_px_q
 \end{aligned} \quad (4)$$

known as a Iwachnienko's polynomial.

The polynomial coefficients (4) are determined for training observations t by means of least squares method, i.e. based on the condition:

$$S_R = \sum_{i=1}^t (y_i - y_i^*)^2 = \min \quad (5)$$

where:

$$\begin{aligned}
 y_i^* &= A_{pq} + B_{pq}x_{ip} + C_{pq}x_{iq} + D_{pq}x_{ip}^2 \\
 &+ E_{pq}x_{iq}^2 + F_{pq}x_{ip}x_{iq}
 \end{aligned} \quad (6)$$

It is jointly created $m(m-1)$ of polynomials. Every polynomial y_i^* (6) is determined for all data of the matrix X. Calculated values are placed in separate columns of the auxiliary matrix Z.

In the second step for every column $j = 1, 2, \dots, m(m-1)$ of the matrix Z it is determined a regularity criterion based on the formula:

$$r_j^2 = \frac{\sum_{i=t+1}^n (y_i - z_{ij})^2}{\sum_{i=t+1}^n y_i^2} \quad (7)$$

where:

i – next observation of the matrix X,

$j = 1, 2, \dots, m(m-1)$ column number of the matrix Z.

A received value of regularity criterion (see (7)) is an evaluation of quality of a given polynomial.

In the third step there is a selection of the best polynomials (of the least coefficient value r_j). On the assumption that the population of polynomials is weak, from the matrix Z there are selected m columns which are transferred to the matrix X. In this way the output data becomes the input data for the next generation. A minimal value of regularity criterion r_j is determined. The coefficients' values of selected polynomials are retained.

This process is repeated till the values of regularity criterion (see (6)) decrease. When the process is completed, the best polynomial from among the polynomials of the previous generation is selected. A polynomial being a model of the object is a result of algorithm operation.

In the case under consideration, for the training data, the following values of regularity criterion are obtained:

$$\begin{aligned}
 R_{x_1, x_2} &= 6,58 \\
 R_{x_1, x_3} &= 14,99 \\
 R_{x_2, x_3} &= 10,32
 \end{aligned}$$

In this way, as giving the least error of modelling, "the best" polynomial is selected depending on the enterprise's income (y), for the training data:

$$y = F(x_1, x_2) = -8271,81 - 1,97x_1 + 11,14x_2 + 0,02x_1^2 + 0,002x_2^2 + 0,0002x_1x_2 \quad (8)$$

where:

$F(x_1, x_2)$ – income of SME sector enterprise,

x_1 – 1,

x_2 – sales in the enterprise.

The value $F(x_1, x_2)$ is a forecast value of income for the enterprise depending on a current value x_2 .

The following values of regularity criterion are obtained for the test data:

$$R_{x_1, x_2} = 0,7$$

$$R_{x_1, x_3} = 12,64$$

$$R_{x_2 x_3} = 1,1$$

In this way, as giving the least error of modelling, "the best" polynomial $y = F(x_1, x_2)$ is selected depending on the enterprise's income (y). The operations on the test data confirmed a selection correctness of "the best" polynomial for the training data. The presented considerations related to the GMDH allow to specify individual stages of the design of polynomial decision making model of DSS information system selection for the enterprise.

3 Polynomial decision making model of decision support system selection

The design of decision making model of decision support system selection starts with the collection of information on an investigated object. There can be the data coming from the experts or there can be the empirical data obtained as a result of the object functioning observation [8].

The model identification includes:

- determination of characteristics (functionalities) of given information system used in a given enterprise,
- determination of functioning indexes in a given functional department of the enterprise on the basis of measurement in an investigated object (enterprise),
- control of forecast quality of the values of arbitrarily selected functioning indexes by means of selected model on the basis of comparison of forecast values of the indexes with the real values of these indexes in the enterprise.

For the purpose of the determination of the model it is assumed that:

- the base of functioning indexes of the sales department in the SME and information system parameters (system functionalities) (see Table 3 and Table 4) constitutes a base of building of the model,
- the values of input parameters (information system parameters, values of functioning indexes of a given department in the enterprise) and output parameter (value of profit in the enterprise or value of enterprise effectiveness index) should not change within a radically short period of time.

3.1 Design methodology of polynomial decision making model of DSS selection

Stage 1 Identification

A GMDH multi-level algorithm enables to make a synthesis of the model for selected characteristics of given DSS information system (i.e. functionalities of this DSS) with arbitrarily selected indexed of a given department of the enterprise. Both mentioned elements of the algorithm are determined by the designer. Therefore, the modelling must be preceded by an identification phase of the model's element.

In this phase the investigations in the SME sector enterprise (see Table 3) related to the functionalities of implemented information solution on the basis of an example of sales department are carried out. A closed set of business processes⁵ supported by an information tool implemented in the enterprise and a set of values of functioning indexes of the sales department (see Table 4) are obtained. It is assumed that a model of DSS information system selection of the enterprise is in the form of second-degree polynomial of two variables. A selection of partial polynomials is made by means of regularity criterion (7).

The value base of information system parameters (functionalities, see Table 3) constitutes a set of characteristics (functionalities) of information system in a given enterprise. The bases of functioning indexes of a given department in the enterprise, parameters of information system and output values (see Table 3, Table 4 and Table 5) can be freely built by the designer.

⁵ Business processes – a set of mutually connected functions, limited by the rules, in order to achieve a set of economic objectives appropriate for a given enterprise within a specified time limit, [Shang S., Seddon P., 2000].

Table3. The value base of information system parameters in the SME (system functionalities) for the sales department
(value 1: the task is realized by the system, value 0: the task is not realized by the system)

(source: self study)

Functionality of information system in SME	Value of task realized by system
x ₁ : Search for contacts	1
x ₂ : Qualification of potential customers	0
x ₃ : Analysis of market penetration possibilities and degree	0
x ₄ : Determination of target markets	0
x ₅ : Investigation of the customer's situation and needs	0
x ₆ : Preparation of a map of the customer's decision making process and his important factors	1
x ₇ : Development of sales conditions	0
x ₈ : Determination of organizational persons impacting on purchase decisions	1
x ₉ : Determination of a kind of contacts with the customer	1
x ₁₀ : Search for and determination of potential customers	0
x ₁₁ : Delivery of information on the company's products and services to the customer	0
x ₁₂ : Order of advertisements in media	0
x ₁₃ : Development of layout and graphic form of advertisements in media	1
x ₁₄ : Direct talks with the customer at the seat of the company	0
x ₁₅ : Direct talks with the customer at the seat of the customer	0
x ₁₆ : Phone talks with the customer	0
x ₁₇ : Development of product/service presentation and offer	1
x ₁₈ : Trips to the customer	0
x ₁₉ : Information on the product's properties	1
x ₂₀ : Comparison of the company's offer with competitive offers	1
x ₂₁ : Cooperation when solving the customer's problems	0
x ₂₂ : Persuasion, negotiation and determination of sales conditions	0
x ₂₃ : Formulation of proposals in writing and preparation of documentation	1
x ₂₄ : Submission of final offer	0
x ₂₅ : Conclusion of transaction	1
x ₂₆ : Preparation of orders and supplementary orders	1
x ₂₇ : Register of order to the deliverer	1
x ₂₈ : Register of purchase	1
x ₂₉ : Register of article sales and hand-over	1
x ₃₀ : Invoicing	1
x ₃₁ : Register of value returns and corrections to trade documents	1
x ₃₂ : Solving problems related to crediting, invoicing, execution of receivables	1
x ₃₃ : Complaints and collection of articles from the customer	1
x ₃₄ : Inventory, control of warehouse balances	1
x ₃₅ : Monitoring of warehouse balances	1
x ₃₆ : Development of marketing programs	1
x ₃₇ : Execution of market analyses for the needs of the customer	1
x ₃₈ : Presentation of new products and technologies	0
x ₃₉ : Solving problems related to production	0
x ₄₀ : Participation in meetings	0
x ₄₁ : Administration work	1

x ₄₂ : Participation in trainings	0
x ₄₃ : Supervision over sales plan	1
x ₄₄ : Handling of complaints – quantitative and value	1
x ₄₅ : Collection of data in the data base of the customers, potential customers, markets, etc.	1
x ₄₆ : Notification of dispatch	0
x ₄₇ : Sales forecasts	1
x ₄₈ : Segmentation of the customers	1
x ₄₉ : Contact centre with the customers	1
x ₅₀ : Auction of the deliverers	1
x ₅₁ : Settlement of the sales representatives	1
x ₅₂ : Planning of routes of the sales representatives	1
x ₅₃ : Planning of types and elements of visits of the sales representatives	1
x ₅₄ : Creation of tasks of the sales representatives	1
x ₅₅ : Reporting own articles and presence of the competition's article at the customer's	1
x ₅₆ : Creation of sales plans for sales regions	1

Table 4. Selected functionality indexes of sales department in the enterprise
(source: self study)

Functionality indexes of sales department	Value		
	2007	2008	2009
x ₁ : Share of orders realized on time (number of orders realized in at a requested time / number of received orders x 100%)	0,84	0,91	0,96
x ₂ : Share of advertised deliveries (number of advertised deliveries / total number of deliveries)	0,06	0,07	0,57
x ₃ : Profitability of assets (profit/assets)	0,14	0,13	0,13
x ₄ : Rotation of reserves (revenue / reserves)	7,17	6,75	6,45
x ₅ : Profitability of equity (profit/equity)	0,32	0,30	0,35
x ₆ : Work productivity (revenues from sales/value of work of the total employed)	4,72	11,30	11,76

Table 5 Values of output data: enterprise profit, enterprise effectiveness index
(source: self study)

Output data of decision making model	Value		
	2007	2008	2009
y ₁ : Profit in the enterprise (in thousand PLN)	773	710	805
y ₂ : Enterprise effectiveness (receivables rotation index) (revenues from sales / average revenues balance)	8,54	10,3	10,69

In the case under consideration we receive:

$$X = \begin{bmatrix} 0,84 & 0,06 & 0,14 & 7,17 & 0,32 & 4,72 \\ 0,91 & 0,07 & 0,13 & 6,75 & 0,30 & 11,30 \\ 0,96 & 0,57 & 0,13 & 6,45 & 0,35 & 11,76 \end{bmatrix}$$

$$\text{and } y_1 = \begin{bmatrix} 773 \\ 710 \\ 805 \end{bmatrix} \text{ or } y_2 = \begin{bmatrix} 8,54 \\ 10,3 \\ 10,69 \end{bmatrix}$$

Stage 2 Determination of family (population) of partial models

The design of a model in the GMDH algorithm is realized in a step-by-step manner. A family of regression polynomials is generated in every next step. Because it is determined that each of them is a function of two variables, these polynomials are created for all possible pairs of arguments.

The task of GMDH algorithm operation is to determine "the best" polynomial of the least regularity criterion value (see 2.VII) for the object (the enterprise of the sector). A process of GMDH algorithm evaluation is carried out on the basis of the data included in the base of SME functioning indexes and information system parameters (see Table 3, Table 4 and Table 5).

Stage 3 Selection of partial models

When the family of regression polynomials is generated, there is a selection of these ones from them which approximate an investigated dependence between the characteristics of given DSS information system (i.e. functionalities of this DSS) with arbitrarily selected indexes of given functional department of the enterprise the best (see Table 3, Table 4 and Table 5).

The least value of regularity criterion is found for every partial solution. The stages 2 and 3 are repeated till this value stops decreasing. It means that an optimal model is found. It is a model (polynomial of regression) for which a regularity criterion reached the least value. The following values of regularity criterion are received:

- for y_1 :

$$\begin{aligned} R_{x_1, x_2} &= 0,73 \\ R_{x_1, x_3} &= 2,51E+0,9 \\ R_{x_1, x_4} &= 1,99E+22 \\ R_{x_1, x_5} &= 3,89E+09 \\ R_{x_1, x_6} &= 5,11E+10 \\ R_{x_2, x_3} &= 1,04E+10 \\ R_{x_2, x_4} &= 0,687365 \text{ (the least value} \\ &\quad \text{of regularity criterion)} \\ R_{x_2, x_5} &= 8,79E+12 \\ R_{x_2, x_6} &= 1,45E+11 \\ R_{x_3, x_4} &= 5,23E+10 \\ R_{x_3, x_5} &= 0,71 \\ R_{x_3, x_6} &= 2,63E+10 \\ R_{x_4, x_5} &= 2,27 \\ R_{x_4, x_6} &= 2,32 \\ R_{x_5, x_6} &= 0,95 \end{aligned}$$

In this way, as giving the least error of modelling, "the best" polynomial is selected depending on the enterprise's profit (y_1):

$$y_1 = F(x_2, x_4) = 585,57 + 0,19x_1 + 0,22x_3 - 0,0005x_1^2 + 0,0008x_3^2 + 0,0005x_1x_3 \quad (9)$$

where:

$F(x_2, x_4)$ – profit of SME sector enterprise,

x_1 – "share of advertised deliveries" index,

x_3 – "assets / rotation of reserves" index.

The value $F(x_2, x_4)$ is a forecast profit value for the enterprise after the implementation of DSS (depending on a current values x_2 and x_4).

For the exemplary values $x_2 = 0,02$ and $x_4 = 6$, the profit value for the enterprise after the implementation of DSS should amount to:

$$y_1 = F(x_2, x_4) = 586 \text{ thousand,}$$

- for y_2 :

the following values of regularity criterion are received:

$$\begin{aligned} R_{x_1, x_2} &= 0,83 \\ R_{x_1, x_3} &= 0,30 \text{ (the least value of regularity criterion)} \\ R_{x_1, x_4} &= 0,60 \\ R_{x_1, x_5} &= 2,4 \\ R_{x_1, x_6} &= 1,43E+11 \\ R_{x_2, x_3} &= 1,38E+10 \\ R_{x_2, x_4} &= 0,7 \\ R_{x_2, x_5} &= 1,92 \\ R_{x_2, x_6} &= 0,37 \\ R_{x_3, x_4} &= 5,4E+10 \\ R_{x_3, x_5} &= 6,96E+10 \\ R_{x_3, x_6} &= 1,81 \\ R_{x_4, x_5} &= 2,05 \\ R_{x_4, x_6} &= 1,14E+12 \\ R_{x_5, x_6} &= 1,45E+11 \end{aligned}$$

and "the best" polynomial is selected depending on the enterprise's effectiveness (y_2):

$$y_2 = F(x_1, x_3) = 48,46 - 6,11x_1 - 1,34x_3 + 0,52x_1^2 - 0,07x_3^2 - 0,11x_1x_3 \quad (10)$$

where:

$F(x_1, x_3)$ – effectiveness of SME sector enterprise,

x_1 – "share of orders realized on time" index,

x_3 – "profitability of assets" index.

The value $F(x_1, x_3)$ is a forecast effectiveness value for the enterprise after the implementation of DSS (depending on a current values x_1 and x_3).

For the exemplary values $x_1 = 0,8$ and $x_3 = 0,12$, the effectiveness value for the enterprise after the implementation of DSS S should amount to:

$$y_2 = F(x_1, x_3) = 43,81$$

The polynomial decision making model for the enterprise's profit is built of groups of elements, i.e. functioning indexes of sales department of the enterprise, parameters of information system and by means of GMDH algorithm. The decision making model allows to determine the values of control indexes to execute a selection of DSS information system. On the basis of operation effectiveness of the implemented information system (see Table 3, Table 4 and Table 5) there is a possibility of DSS information system selec-

tion for the enterprise with regard to the forecast ("the best") profit values or "enterprise effectiveness" after the implementation of DSS. On the basis of the forecast values of these indexes, the management board of the enterprise makes a decision to purchase the DSS.

4 Multi-criteria selection methodology of decision support system

A building procedure of polynomial decision making model (see Figure 1) is developed in order to develop the multi-criteria selection methodology of decision support system.

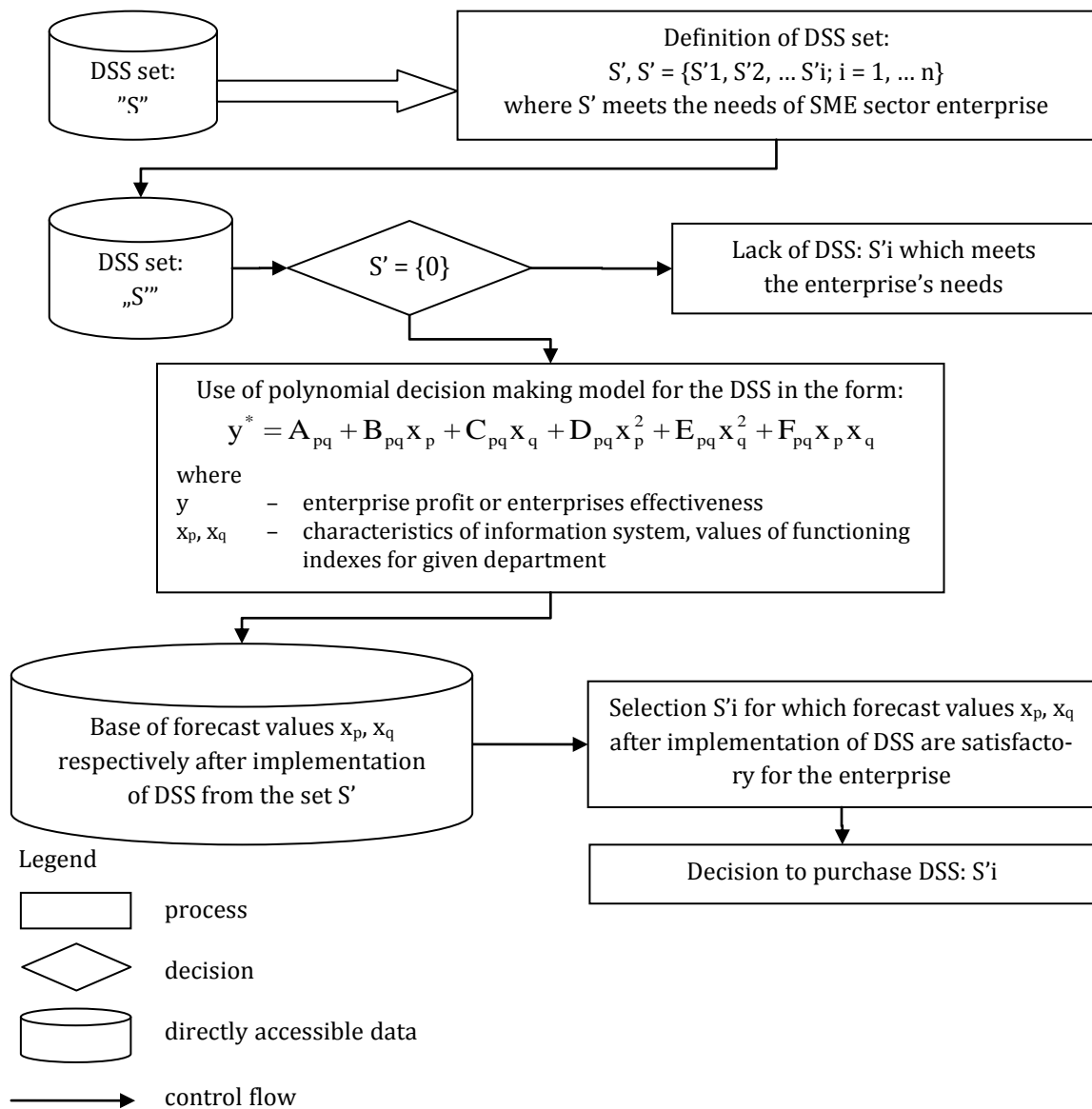

Figure 1. DSS varianting procedure (source: self study)

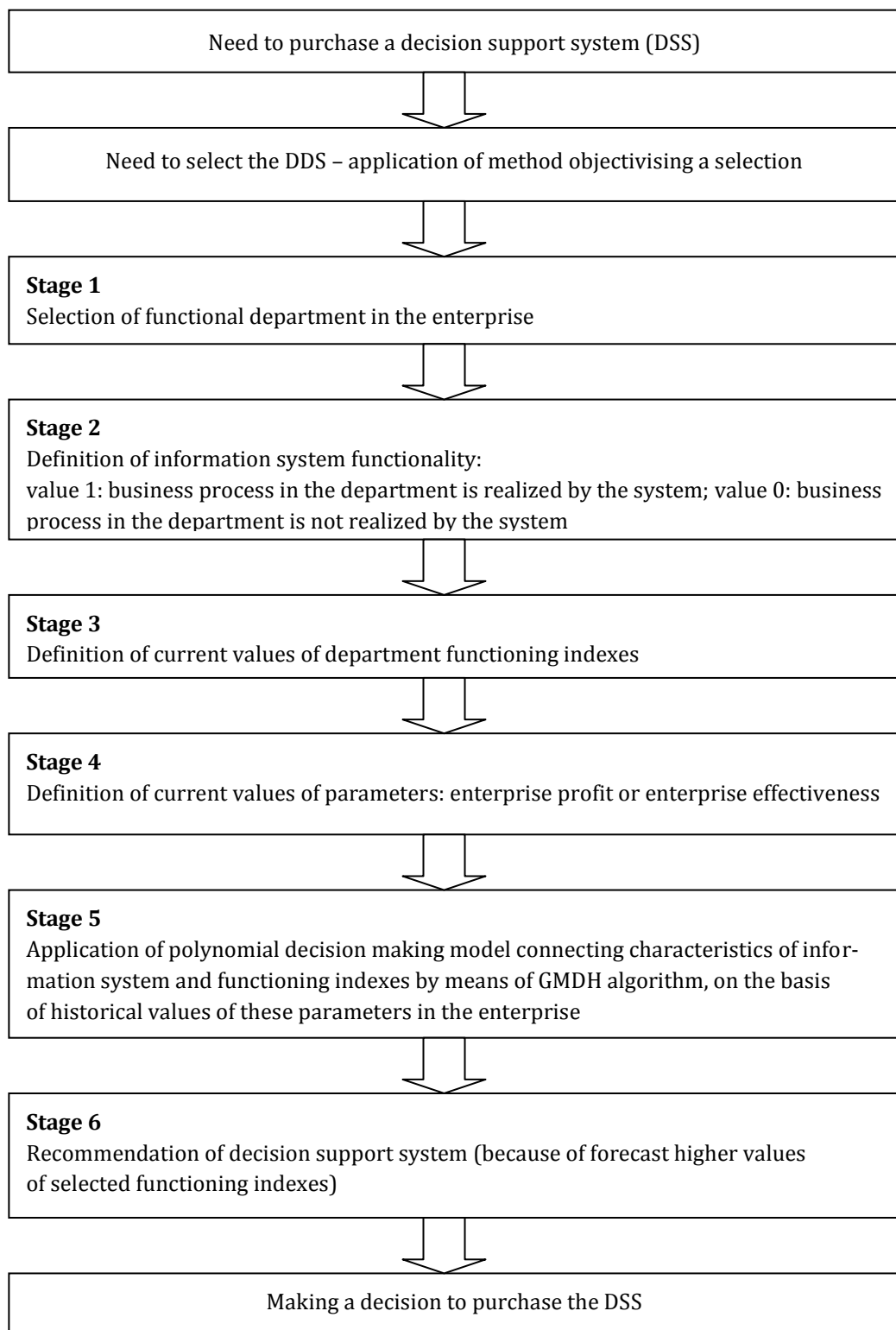

Figure 2. Decision support system selection methodology
(source: self study)

The following realization stages of this procedure are accepted:

- Stage 1 - defining the system's parameters meeting the enterprise's needs by the deliverer of DSS,
- Stage 2 - using a polynomial decision making model respectively for a parameter "profit" or parameter "effectiveness",
- Stage 3 - determining forecast values of selected functioning indexes of a given department in the enterprise after the implementation of DSS,
- Stage 4 - determining a scheme of the enterprise's conduct in a DSS selection process.

The main purpose of this point is to present a multicriteria selection methodology of decision support system on the assumption that an information system is implemented in the enterprise (see Figure 2).

The presented methodology objectivising a selection of decision support system gives additional possibilities to achieve a forecast of values of the enterprise's functioning indexes as a result of DSS implementation. The values of defined indexes in the enterprise, being before a decision to implement the system, are estimated on the basis of polynomial decision making model. A developed forecast allows to make an objective selection of DSS.

There are several possibilities of further work on an undertaken subject. It is possible to modify accepted assumptions. A modification of the assumption related the number of polynomials under consideration seems to be the simplest. It is assumed that as many polynomials go to the next iteration as many columns of matrix X are there. It is probable that an increase of the number of polynomials going to the next iteration causes an improvement of quality of the final polynomial. The executed tests showed that a partial polynomial formed for the columns p, q is different from a polynomial formed for the columns q, p . A GMDH algorithm, in order to limit a number of formed polynomials, assumes that only the polynomials for the columns p, q for which $p < q$ are formed. The alteration of this assumption and the formation of polynomials for all pairs p, q in every iteration is possible. Apart from the algorithm modification, a work on improvement of input data of the algorithm is possible as well.

There is a number of examples of practical application of GMDH, based on the sets of retrospective data [3]:

- in Great Britain, in 1980-1990, using GMDH, a forecast of inflation changes in the country for the

next 10 years was developed (a model of inflation changes achieved by means of GMDH was identical with real values of the inflation in Great Britain in 1990-2000),

- in the United States, in 1990-2000, using GMDH, a forecast of development of main factors of economical growth in the country was developed,
- in the Ukraine, in 1990-2000, using GMDH, a normative forecast of macroeconomic processes for the next 10 years was developed,
- using GMDH, a forecast of changes in Lake Baikal was developed,
- in the United States, in 1990-2000, a GMDH was applied to diagnostics of cancer diseases,
- in the beginning of the 70-ties American enterprise, Adptronics Inc., applied GMDH to the equipment of quality control of materials used in aviation,
- ComputerLand (Wrocław) makes use of GMDH to detect defects of digital and analogue power supply adaptor of electronic circuit,
- a control of exactness of technological track elements is carried out by means of GMDH in the boiler station evaporation station of Lublin sugar refinery (Poland). The researches related to the development in integration of methods (among other things GMDH) and process diagnostics techniques (in particular control valves) in Lublin sugar refinery were carried out within the framework of DAMADICS project⁶.

The above mentioned examples show a wide GMDH application.

5 Summary

A development of information technologies provides with more and more new solutions within the scope of decision support systems. The producers of these systems adjust particular areas of their functionalities the needs of enterprises. A growing offer of such systems forces a need to develop a method objectivising their estimation – a method supporting a selection of determined packet ensuring the fulfilment of individual needs of the enterprise.

⁶ DAMADICS (Development and Application of Methods for Actuator Diagnosis in Industrial Control Systems) – a project realized within the framework of 5. Frame Program, in 2000-2003 whose coordinator is professor Ronald J. Patton from The University of Hull in Great Britain.

6 References

- [1] Farlow S.J. (ed.) - *Self-organizing Methods in Modelling: GMDH-type Algorithms*. Marcel Dekker Inc., New York 1984.
- [2] Goldberg D.E. - *Algorytmy genetyczne i ich zastosowanie*. WNT, Warszawa 1995.
- [3] http://www.gmdh.net/GMDH_exa.htm, June 2010.
- [4] Hunt E.B., Marin, J. & Stone P.J. - *Experiments in induction*. Academic Press, New York 1966.
- [5] Iwachnienko A.G. - *Polynomial theory of complex systems* [in] IEEE Trans. Systems, Man and Cybernetics, Vol. SMC-1, No. 4, 1971.
- [6] Osowski S. - *Sieci neuronowe w ujęciu algorytmicznym*. Wydawnictwo Naukowo-Techniczne, Warszawa 1996.
- [7] Patalas J., Kłós S., Stryjski R. - *Ocena efektywności wdrożeń systemów klasy ERP w SME* [in] Komputerowo zintegrowane zarządzanie (ed. R. Knosala). WNT, Warszawa 2005.
- [8] Patalas J., Krupa T. - *The ERP class system objective assessment method* [in] Applied Computer Science, Vol. 1, No. 1, pp. 115-132, 2005.
- [9] Shang S., Seddon P. - *A comprehensive framework for classifying the benefits of ERP systems, 2000* [in] Proceedings of AMCIS'2000, Vol. II, 2000, pp. 1005-1014.
- [10] Tadeusiewicz R. - *Sieci neuronowe*. Akademicka Oficyna Wydawnicza RM, Warszawa 1993.

IT SYSTEMS SECURITY MANAGEMENT IN MIGRATION PROCESS

Sylwester PIĘTA

Faculty of Management

Warsaw University of Technology, 02-524 Warszawa, Poland

e-mail: s.pieta@wz.pw.edu.pl

Abstract: This paper looks at the issue of IT systems migration as well as problems related to security policy in migration processes. Problem of migration is viewed in a broad context of changes which occur during construction or modernization of an IT system. Migration projects were classified against the background of wide spectrum of informatization strategy issues and sources of threats to information security were pointed out. Also, guidelines for improvement of security in migration process were presented.

Key words: informatization strategy, migration, migration scenario, software versioning, upgrade, source system, target system, security, system resources, data and information security, risk management, information systems protection, security policy, business continuity, system project, project management.

1 Introduction

The functioning of a modern organization encompasses, next to business strategy, informatization strategy, which should bring together both business and IT goals. It is, apart from natural systems evolution, the key factor which causes IT systems to constantly undergo changes. Sometimes, these are minor changes connected with functional development, while, some other times, a giant technological leaps of system platform and business applications. IT infrastructure, similarly to every other organizational resource, requires appropriate management and exploitation – changes disturb this process. In principle, only seldom the situation is stable in the long term, when systems can be exploited normally, in accordance with the established business goals and the introduced security policy.

IT systems security and IT systems migration are, today, two well-known areas for the managing and IT staff. They are known because of their fundamental influence on organizational development and business continuity.

Successful migration of IT system and its information surrounding into new organizational and technical conditions requires this process to be treated as an undertaking of strategic character. Therefore, it is best to prepare the migration process as well as plan and control its implementation on the basis of such best practices and management, support, maintenance and IT

development models as COBIT¹, ITIL² or CMM/CMMi³.

Right implementation of new information technologies enables the organization to enter into equal competitive struggle or even become the industry leader, while, on the other hand, implementation failures may become extremely costly, leading even to organization bankruptcy. It is similar in the area of security. Flaws of security policy constitute potential trouble for organization. Increased importance of electronic data processing requires taking broader protective measures towards the infrastructure used, as well as information and data themselves. One investment-stimulating factor is surely the fear of losing data, but also, for some industries, adequate law regulations and, more and more often, care for the company goodwill.

Process of IT system migration is a remarkable situation for an organization. Because of appearance of new technologies, new tasks for employees, new personnel for the organization, we deal with threats in the field covered by migration, which not only may not be included in procedures but also may not be considered at all.

¹ COBIT (Control Objectives for Information) – coherent and clear model/set of best practices for IT management, addressed to managers, auditors and users of information technologies.

² ITIL® (Information Technology Infrastructure Library) – set of complex recommendations of IT industry, on the basis of which the international norm for IT service management – ISO/IEC 20000 Service Management, was created.

³ CMM/CMMi (Capability Maturity Model *Integration*) – general model which determines organization maturity with regard to realization of given goals and enables to improve organizational inner processes in an organized and ordered manner.

This work concentrates on describing the issue of migration and on information security in migration processes against the background of informatization strategy. Description of informatization strategy has been limited to necessary minimum. In order to present a complex approach to the problem of security, one has to speak of information security of organization. Complete security policy consists of organizational matters and information technologies both in routine utilization and in emergency situations, such as: malfunctions, crises and migrations.

1.1 Informatization strategy

Strategy is most often defined as “clearly formulated goals together with means, methods and rules of their achievement”. Strategy, from the moment of their establishment, has a defined time horizon, in which it operates. Works concerning strategy improvement should be carried out continuously in such a way, that it always precedes executive projects connected with it – in this case, information system migration project.

From the informatization strategy should result the program (plan) for its realization, especially:

- assumptions, that is limitations (spatial, financial, staff, time) and target parameters (flows, capacities, performances),
- necessary information (models, methods), software (operation systems, software tools) and hardware resources,
- operations and design processes as well as project management methods (including requirements concerning flexibility and quality of solutions).

When establishing informatization strategy, one has to pay attention to:

- differentiation between IT infrastructure (hardware, software), information system (information sources, information processing procedures, organizational bylaws) and IT system (databases, software tools, application programs, procedures and methods of data processing),
- necessity to systematically identify information requirements in organizational structure and its environment,
- necessity to establish a multi-layer integrated information system model and IT system model,
- necessity to follow and analyze development plans and undertakings of competition and to gather information on IT systems and technologies.

Examples of technical and organizational undertakings, which should be included (calculated) in informatization strategy concerning the issue of IT system migration are:

- target structure and development level of an information system, part of which will be the IT system to undergo migration,
- systematic identification of information requirements of the new information system users,
- construction and development of a target IT system in an integrated architecture, which will guarantee integration of all information processes at a limited number of technological (executive) platforms.

In the IT strategies realization programs, it is advisable to pay particular attention to some groups of discrepancies, which accompany design or modernization of an integrated IT system discrepancy between:

- diversity and integration of product service processes in the IT system,
- diffusion and integration of data in the IT system databases,
- the need to modernize and the need to fulfill ad hoc functions,
- security and accessibility of IT system resources,
- current state of the IT system (before migration) and requirements set for the new system (after migration).

Minimum list of informatization program evaluation criteria:

- standard of technical and program realization of system after migration (modernity of the proposed solutions),
- operational reliability and level of system security,
- ensuring organizational business continuity during the whole migration process,
- time-schedule and costs of execution,
- increased possibility to broaden system functionality after migration,
- simplicity of system administration no lesser than before migration.

1.2 Problem of migration

A dozen or several dozen years ago there would often be a situation, when an IT system was introduced to an organization in order to support or replace manual tasks carried out by personnel. Today, it is most often a change within an already existing infrastructure. Dur-

ing the use of IT systems comes the obvious need of expanding, changing or replacing them. Each case comes with specific requirements characteristic for particular business. It should be noted, that launching a new IT system in parallel to another system, i.e. paper one, does not carry the threat of disrupting business continuity. In case of migration processes, in spite of all the preventive measures, there comes a moment when business support is switched from an appropriately working system to a new system burdened with potential errors. By maintaining for a longer period the parallel work of the old system, we do leave ourselves with a way for retreat, however, this comes with at least short stoppage and, as a rule, with costs adequate to the system "weight".

Migration means entering a path full of potential threats to business continuity and, additionally, all activities in this process, by their nature, open the possibilities of undesirable events from the point of view of security.

Expenses for a new, improved system will find justification from the point of view of management staff. However, from the economic departments' point of view, ensuring security does not result in increased sales or profit. Such investments are hard to force through in budget plans, as they do not bring measurable, easy to calculate benefits. ROSI⁴ index, used in some foreign companies is, most of the time, wrongly defined if defined at all.

2 Definitions

In the beginning, a couple of definitions are presented which will become helpful in some further considerations.

- Migration

Migration⁵ (lat. 'migratio' = resettlement) – 1. Journey, resettlement of people within country, 2. Active or passive resettlement of plants or animals from one area to another.

Migration with regard to IT systems refers to process of changes in an IT system, which aims at moving from a state called source system to a state called target system. Migration-related issues may consist of technological (software, hardware), organizational and legal problems.

Reasons for the migration necessity may be of various nature: from necessity to run minor system updates to issues related to merging or dividing the organization or its units. In the research [12] by DiS (Market research agency DiS) entitled "ERP systems migrations" the most often reason for migration was the necessity to broaden functionality, and the second most often was the change of company IT strategy. Changes in capital structure are considered one of the most often reasons for organizational migrations.

It is necessary to add that, in all cases, migration is connected with high expenditures, relatively high in comparison to the cost of building an IT system from scratch. Migration is most often carried out in medium and large organizations, where complexity of an IT system can be measured with the use of function point, i.e. number of entries and exits from the system, or the number of entities [15].

- Source system

In this work source system is defined as a state of an IT system, which encompasses the following resources: hardware, software, human resources, organizational procedures and information resources, before launching of migration process.

- Target environment

Target environment is defined as such a state of IT system, which encompasses the following resources: hardware, software, human resources, organizational procedures and information resources, after migration process is finished. Migration process may influence all the above mentioned resources in order to move from source system to target environment.

3 Classification of migration projects

The classification presented below has, in some aspects, an arbitrary character, which obviously, results in the fact that some elements of the defined migration types may be mixed, i.e. technical upgrade and realization of minor improvements, technical upgrade and authorization list or postponed realization. Organizational migration, on the other hand, will, in principle, be connected with a number of system upgrades. Within the classification, the reasons for launching migration projects are presented:

- upgrade

- it is an undertaking which consists in updating the version of software used; most often, it is connected with adding new functions to the sys-

⁴ Return On Security Investment.

⁵ Foreign Words Dictionary, PWN 1980, edited by Jan Tokarski.

- tem or removing significant errors; designations used in the system version designation scheme are mentioned in section 9.1 Versioning,
- reasons: appearance of new version containing new functions, removal of significant errors, necessity to align the data format in the exchange with other users/systems,
- technical migration
 - project consisting of changing the system or the operational systems, hardware or access methods, when possible without introduction of any improvements to the IT system functionality,
 - reasons: appearance of new version of software which requires new resources such as operation system or hardware, routine activity consisting in periodical replacement of hardware, security measures – replacing the hardware-system platform with a safer one,
- functional migration
 - aim of this project is to implement improvements or introduce brand new functions to the system,
 - reasons: necessity to introduce new functions to the system,
- placement migration
 - alteration of functional migration; aim of this project is to introduce changes and improvements which enable use of the system by people, who use different language than the default one; in principle, this requires bigger amount of work, which is not only directed at translation, but also: user profile expansion, adding dictionaries, expansion of parametric reporting,
 - reasons: necessity to introduce new system functions available in a few languages; expansion of the organization to other countries,
- organizational migration
 - the purpose of this project is to adjust the system to organizational changes,
 - reasons: changes in capital structure such as merger or division,
- physical migration
 - the aim of this kind of project is to adjust the system to localization changes within organization; in some cases, in order to maintain business continuity, it requires establishing a twin system

for the period of the project, which may make it extremely costly,

- reasons: physical organization movement to a new headquarters, moving the server room or changing service provider,
- reconstructive migration
 - the aim of this type of project is to reconstruct the system after a critical situation with regard to source environment (primary IT system working environment); critical situations are, among others: fire, flooding, theft, catastrophe; in some situations, in order to maintain business continuity, it is necessary to have a back-up location for the system; because of the costs, complete functionality is rarely located there,
 - reasons: physical damage of the primary environment, moving the organization to new headquarters after critical event or catastrophe.

4 Resources subject to migration

All types of material and immaterial technical means are subject to migration. The most important ones are presented below.

4.1 Network infrastructure

Network infrastructure encompasses issues related to hardware used for building the computer network as well as type and topology of the network. In case of source system migration both wireless and cable network devices such as: network card, routers, switches, bridges, access points, cables (their type), as well as modems and hardware security solutions have to be taken into account. For the purpose of migration the Table 1 can be used.

4.2 DNS – addressing of computers and devices

An important issue in the migration process is granting addresses to network devices, including end-users' computer systems and servers.

Source system hardware has its own set of addresses for devices, which, depending on the type of migration, may migrate according to the following rules:

- set of addresses and domain names remains unchanged,

Table 1. Migration (*source: self study*)

Device name	No. before	No. after	Remarks
Wired networks			
Ethernet card			
Router			
Switch			
Bridge			
Modem			
Firewall			
Access servers and devices			
Wireless networks			
WLAN card (USB, PCMCIA)			
Access point (AP)			
Wireless router			
Wireless bridge			
Electric network bridge			
Wireless modem (GPRS, EDGE, UMTS)			
Others			
Hardware systems IDS/IPS			
Hardware firewall systems			
Hardware gates			
Wireless Network hardware security			
Radius / Diameter Servers			
IDS/IPS Wireless hardware systems			

- set of addresses and domain names is extended,
- set of addresses and domain names is limited,
- set of addresses and domain names is extended,
- set of addresses and domain names is limited,
- set of addresses and domain names is completely changed.

In case when the ability to ascribe IP addresses and domain names remains within competence of the team responsible for migration, determination of final set of addresses may be formed freely, unless it disturbs organizational, country and international norms.

If, however, changing the IP addresses requires cooperation with third persons, both within the organization and outside of it, it is necessary to include the address changing actions in detail in the schedule of migration, because of the character of DNS [13] system, which is a dispersed base and requires time for refreshing the name servers' content [14].

4.3 E-mail

Among the resources of critical meaning during source system migration, there are issues related to electronic mail, which is a typically virtual concept and encompasses the following problems:

- hardware:
 - determining specifications of outgoing and incoming e-mail servers:
 - determining SMTP applications (Sendmail, Postfix, MS Exchange, Qmail),
 - determining anti-virus applications (clamav, arcavir),
 - determining anti-spam applications (SpamAssassin, Bogofilter),
 - user virtualization (file system or database system),

- way of communication (introduction of TLS protocols), determining client applications:
 - e-mail clients (Outlook, Outlook Express, Thunderbird),
 - webmail (choice of software),
- procedural:
 - establishing electronic mail domain – this point is strictly connected with point 4.2 concerning addressing issue,
 - establishing account naming,
 - establishing aliases naming (virtual users or procedures of e-mail address construction),
 - procedure for opening and removing accounts,
 - procedure of archiving and security,
 - security procedures with regard to unwanted mail and malicious software.

Determining rules for use of electronic mail should allow minimizing the number of threats, which are related to use of this service.

4.4 Servers

A server is a computer that has been set aside to provide specific services for the benefit of other computers, systems or users. Among the most common types of servers used in organizations are:

- application server⁶:
 - WWW server,
 - DNS server,
 - FTP server,
 - E-mail server (incoming outgoing),
- file server,
- printer server,
- authorization server,
- database server,
- client.

Hardware requirements set for server differ depending on the scope of services they provide and, subsequently, requirements concerning resources. Basic criterion for hardware solutions with regard to servers are: reliability, ability to realize desired redundancy and quick access to particular services. Role of a server may be served by any computer system, however, the above mentioned limitations make it necessary for computer system designers to use components of higher stan-

dards and parameters. This refers to elements presented in Table 2.

Table 2. List of elements of a high-end server
(source: self study)

	Server
Number of CPU's	≥ 2 (server use)
RAM memory capacity	> 4 GB
Number of PSU's	≥ 2
HDD capacity	> 1 TB
HDD type	SCSI, SAS
UPS	Required
Air Conditioning	Required
Network card	≥ 2

Server systems require appropriate operation system, which enables to use multiple CPU's, address high RAM memory capacity and is compatible with other, advanced solutions. They work under the following operation systems:

- Microsoft Windows Server family,
- Linux systems class,
- UNIX systems class.

Choice of operation system should depend on policy concerning software used in the organization or on applications, which will be used on a given hardware.

4.5 Configuration of servers and devices

Installation and configuration of servers, as well as all other devices accessible in an IT system, is an issue which in a direct and key way influences problems connected with security of the whole system. This process should be carried out and, simultaneously, controlled according to procedures provided by hardware and software producers and, with regard to people, by highly experienced staff members.

Installation and configuration of servers may be divided into two main parts: basic installation and installation of applications. Basic installation should consist of the following elements:

- verification of proper hardware functioning (review of BIOS communicates, etc.),
- choice of OS dependant on the server used,
- primary installation of OS and carrying out hardware performance tests in order to eliminate flawed system elements,

⁶ Application server [online]. Wikipedia : the free encyclopedia, 2008-01-29 17:45Z [access: 2008-02-27 08:16Z]. Internet address: http://pl.wikipedia.org/w/index.php?title=Serwer_aplikacji&oldid=11141122.

- another, actual installation of the OS in the minimum extent which is necessary for proper functioning of a given server (each unnecessary module needs to be updated, therefore may constitute a security loophole in case it is overlooked during update process),
- configuration of key system modules and limitation of access rights to the necessary minimum,
- determining the server access policy (remote, local, passwords and group of administrators).

Installation of applications may proceed according to different schemes, dependant on the type of application. For example, presented below is the installation process of a WWW server:

- obtaining installation version / binary or source files from a trusted source, preferably with use of checksum verification,
- determining the application location in the file system structure,
- source compilation, installation,
- determining application configuration,

- test-run of application,
- checking application security and limiting access rights to the necessary minimum.

Device configuration mainly consists in:

- determining access to devices,
- drivers installation,
- configuration testing.

Network devices are subject to additional verification of access rights and possibly to software updates, while, because of the role they play, they are often the target of attacks.

4.6 User data

Determining user data is a complex process, because the number of services available in the IT system may change in the process of migration. Depending on the range and number of servers, users of the system may be divided into following groups - see Table 3.

Table 3. Types of users in a system (*source: self study*)

User type	Attributes
System user	name, password, account size, user type, user group, login key, name and surname, location in the organization, range of addresses which can be used in the login system, type of access to resources, determining access to resources
Database user	name, password, account size, range of addresses which can be used in the login system, type of access to resources, determining access to resources
E-mail user	name, password, account size, e-mail address
FTP system user	name, password, account size, type of access to resources, determining access to resources

Table 4. List of elements of steering, measurement and control systems (*source: self study*)

Type	Functions
Driver modules	Devices which directly steer the processes
Measuring devices	Sensors, measuring and record-keeping instruments which computerize information about the process and transfer them to SCADA system
Visualization systems	Audio-visual infrastructure for presentation of ongoing processes, presenting calculations
Wiring	Transmission media which connects the IT system with steering, measuring and control devices

Additionally, it should be pointed out that the user has a configured working environment, sometimes referred to as 'profile', in which some configuration parameters and private keys are stored.

Therefore it is sometimes virtually impossible to perform a complete migration. Security copy of the profile has to be preserved in such a way, that, after some time, it is still possible to reach to some element of the environment which was not needed just after the migration and was simply overlooked.

4.7 Printers

Access to printers which exist in the organizational IT system may be realized through:

- giving access to printer with the use of user computer system,
- giving access to printer with the use of printer server (software or hardware),
- giving access to printer with an in-built printer server module through connection to network infrastructure.

Use of printer server enables detailed determination of printer access rules through determination of user rights, parts of network, access time and number of pages to be printed.

4.8 Steering, measurement and control systems

In case of IT systems connected with steered technological or production processes, system migration becomes more complex due to the need to move, back up temporarily or divide measurement and control signals. Such systems are most often called SCADA.

SCADA (Supervisory Control And Data Acquisition) – system which monitors a technological or production process. Basic functions of SCADA software are:

- gathering up-to-date data (measurements),
- visualization of processes on monitors and synoptic tables,
- observation and change of technological parameters,
- remote control of technological processes,
- generation of information on emergencies and malfunctions,
- supporting operator in extraordinary situations (advice system),
- storing archival data about the monitored process.

Key elements of SCADA are presented in Table 4.

5 Migration project management

Migration process management consists of a range of activities, which are necessary to move from source state to target environment in a pre-defined time period.

Among these activities are:

- activities connected with planning and scheduling processes,
- activities connected with project realization,
- activities connected with project control.

As presented above, migration should be treated as any other project and it is characterized by all the aspects of project management. Apart from realization of the above mentioned activities, migration process also requires limiting risk, ensuring communication between people engaged in project realization and their proper motivation. In the process of project management, we deal with a couple types of participants:

- project manager – key role in the project; his tasks include:
 - coordination of tasks between participants,
 - motivating project participants,
 - elimination of problems and threats,
 - communication with project sponsor and participants
- project sponsor – key role in the project with regard to decisions of highest importance. His tasks include:
 - initiation of project realization,
 - choosing the project manager,
 - taking key decisions,
 - changing project budget and deadline,
- project participant – his tasks include carrying out activities and sets of activities which result from the project plan or schedule.

One of possible methodologies which can be used for migration project management is PRINCE2 [16]. Primarily it was used only to manage IT projects, but now it is a methodology independent from area of use. Characteristic for this methodology is the process approach to project management, in which the following main processes are distinguished [16]:

- directing a project,
- planning,
- starting up a project,
- initiating a project,
- controlling a stage,
- managing product delivery,

- managing stage boundaries,
- closing of a project.

However, because of high expectations concerning the management process itself, this methodology should be used in case of large and very large migration processes. Another methodology, or set of best practices of project management, is PMBOK [17]. It encompasses five fundamental groups of processes [17]:

- initiating processes – elaboration of opening document, elaboration of initial project scope,
- planning processes – project management plan development, project scope management planning, project scope planning, work packets establishment, activity definition, activity sequencing, activity resource estimating, activity duration estimating, schedule development, cost estimation, cost budgeting, quality planning, human resources planning, communication planning, risk management planning, risk identification, qualitative risk analysis, quantitative risk analysis, risk reaction planning, purchases planning, contracting planning,
- executing processes – directing and managing project execution, quality assurance, acquiring project team members, project team development, information distribution, gathering offers from sellers, selecting sellers,
- controlling processes – project work monitoring and controlling, integrated change management, scope verification, scope control, schedule control, cost control, quality control, team management, work development reporting, stakeholders management, risk monitoring and control, contract administration,
- closing processes – project closure, contract closure.

5.1 Organizational activity

Efficient leading of migration project requires the following organizational activities.

- appointing appropriate representatives and teams,
- determining budget for new infrastructure and migration process,
- accepting activity schedule.

5.2 IT agent

Tasks:

- elaboration and coordination of network and systems configuration changes, including development,
- coordination of software and hardware purchases,

- contact with contracting parties: subcontractors and implementation companies,
- software legality control.

5.3 Project and implementation team

Tasks:

- establishing detailed projects within each phase,
- carrying out projects,
- commissioning chosen tasks connected with IT system construction to other units,
- moving proposals for appropriate organizational activity.

5.4 Migration projects execution models

Similarly to any other IT undertaking, we may choose either “light” or “heavy” project management methodology. The more complex the migration project is, the stronger the project management mechanisms, documentation and control, should be developed.

6 Migration scenarios

In the strategic phase, which precedes the decision about project execution, choice of a solution should be preceded by analysis of every possible migration scenario. The best solution may be chosen on the basis of points granted in a pre-defined system of criteria and weights.

6.1 Exemplary criteria and scenario network

Depending on the degree of complexity of a migration project, scope of changes may be divided into activity areas or stages, and a couple of scenarios may be derived for each of them. Choice of scenario for each stage will provide us with the realized path within the scenario network. Appropriate scenario network will enable change of path in case of occurrence of new, significant situations such as change of budget, shortage of staff or change of legal regulation, during the project. It has to be pointed out that, as some stage scenarios may exclude one another, a well-prepared scenario network may help to avoid serious mistakes.

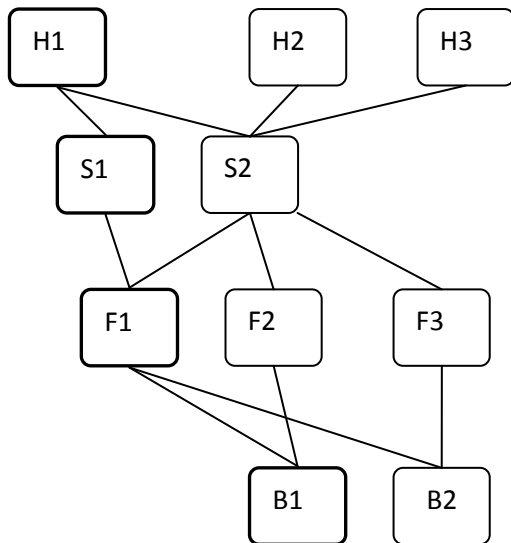

Figure 1. Scenarios Network (*source: self study*)

Network of scenarios, with an indicated chosen path of activity as well as exemplary scenarios, is presented in In Figure 1 it can be seen, that the migration scenario: H1S1F1B1 was chosen. In case of problems with H1 scenario, i.e. delayed procedures concerning hardware or lack of resources for this hardware, a decision about change and choice of another migration path may be taken immediately and it is limited to the H2S2F1B1 scenario or H3S2F1B1 scenario. Having prepared before the analysis of all variants, we decide for H2, which determines the whole path: H2S2F1B1.

6.2 H Scenarios

Scenarios related to choice of hardware:

- H1 Scenario - purchase of new hardware,
- H2 Scenario - installation on existing hardware,
- H3 Scenario - hardware outsourcing.

6.3 S Scenarios

Scenarios related to choice of operation system or database.

- S1 Scenario - S_A operation system, B_A database,
- S2 Scenario - S_B operation system, B_B database.

6.4 F scenarios

Scenarios related to functionality:

- F1 Scenario - full functionality from the moment system is started,

- F2 Scenario - functionality launched in stages,
- F3 Scenario - functionality launched in stages.

6.5 B scenarios

Scenarios related to security:

- B1 Scenario - security in the first place,
- B2 Scenario - resignation from chosen security functions in order to speed up activities.

7 Security design

Each IT system is equipped with an appropriate set of tools which increase its security. Below, the ways of security measures design during system exploitation were presented. On the basis of such schemes, the security measures for the period of migration should be prepared.

Security measures may exist in two forms. In the proactive model, they protect resources before an incident occurs. In the reactive model, they are introduced after the incident is detected. Both models ought to be used, which, in an obvious manner, will form up a security-system lifecycle. Classically, in such system, after implementation there comes exploitation process, which includes periodical modernization sometimes stimulated by incidents. An alteration of reactive model is the system of automatic reaction to an occurrence within the preventive model. In both cases security measures have to be coherent and complete. Coherence means that the security measures will work in different operation systems, locations and cooperating institutions. Completeness, with regard to the idea that the chain is as strong as its weakest link, guarantees that each system within the company has the same level of protection.

Hereafter chosen methods of determining security measures for IT systems will be discussed shortly.

7.1 Security system lifecycle

Process of establishing security measures does not differ from generally known IT systems construction schemes. Such stages as analysis, design, implementation and current performance analysis may be distinguished during exploitation of security measures (Figure 2). Details of actions, which will be taken in the higher stages, introduces wide variety of security measures design methods.

Knowledge from analysis or set of conditions resulting from security policy provides us with the boundaries, within which we should generate security elements.

In case of migration, life cycle looks the same. After the migration is finished, security measures undertaken for the period of migration will be removed.

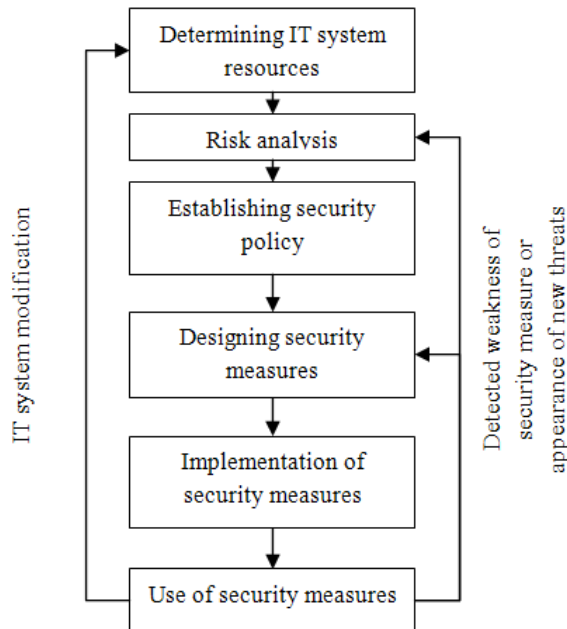

Figure 2. Lifecycle of security measures
(source: self study)

The above scheme requires little comments. The process of determining IT system resources consists of: stocktaking, classification and valuation. Under risk analysis we understand the identification and validation of threats, evaluation of existing security measures, evaluation of losses, determining the acceptable level of risk.

7.2 Expert method

When using this method we consciously resign from extensive analytical processes which precede the choice of security measures.

In many cases a good way to deal with the issue of improving security in a company is to hire a well-trained IT security specialist. After performing a not too detailed analysis of IT resources, without risk analysis and without distinguishing security requirements, security elements may be designed. This method proves

effective in case of relatively uncomplicated systems. Especially in this method it must be stressed, that the system security level is determined by its weakest element.

Security measures in different layers should overlap in such a way, that shortages of one layer will be compensated by another one. In most cases, however, project of security measures should follow a proven methodology.

Expert method does not allow us to evaluate losses, that may be incurred in case of some threat coming true, which is necessary even when we want to insure our resources.

7.3 Choice of security measures based on risk analysis

This method of choosing security measures requires careful analysis of risk related to company resources. An anticipated result of this process, apart from choosing technical security measures themselves, might be all kinds of security policy elements. They might be treated as a sort of security measures as well. For example, security officer, who is an element of security policy, can be treated as a security measure for the purpose of cost analysis.

Risk analysis is one of the elements of risk management process. Identified risk becomes accepted and has to be controlled. Below (see Figure 3), we present a scheme of relationships between security elements, which presents the access path to resources from the environment. Access is always burdened with risk, even if, in case of introduction of security measures, only residual risk is left. It must also be taken into account.

Polish Norm PN-I-13335-1:1999 includes the following definitions:

- risk - probability, that a given risk will address resource or resource group vulnerability, resulting in losses or damaging the resources,
- residual risk - risk which remains after introduction of security measures,
- risk analysis - risk identification, determination of its size and identification of areas which require introduction of security measures,

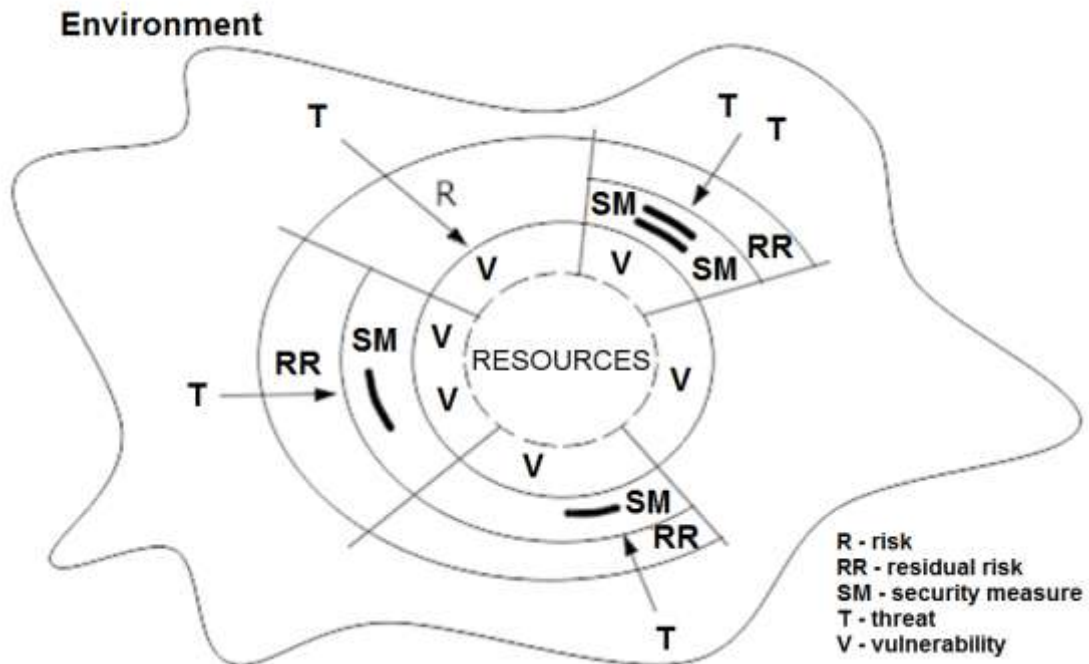

Figure 3. Relationships between security elements (PN-I-13335-1:1999)

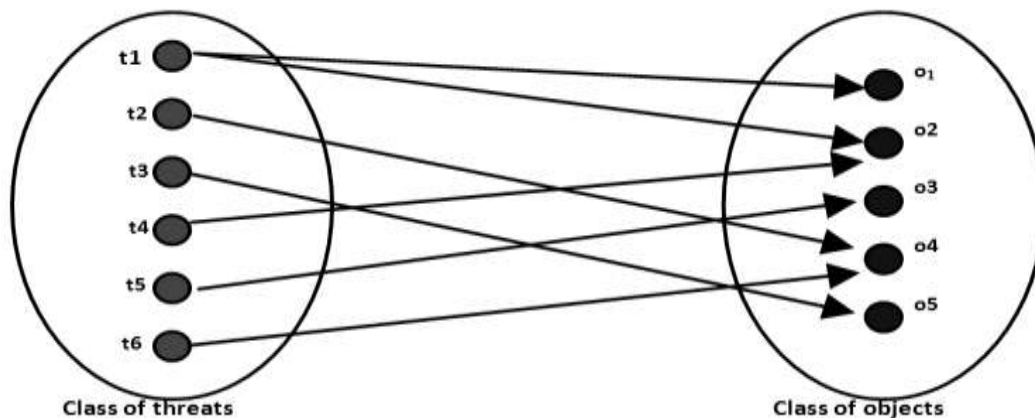

Figure 4. Identification of all possible entrances – threats
(source: self study)

- risk management - complete process of identification, controlling and elimination or minimization of uncertain events' occurrence probability, which may have influence on IT system resources,
- threat - potential cause of undesirable incident, which may result in harm to system or institution,
- vulnerability - resource or resource group weakness, which may be used by threat,
- security measure - risk-reducing practice, procedure or mechanism.

The set of threats is only partially known and undergoes constant changes in time. Process of analysis provides us with detailed information on resources access paths, as presented in Figure 4.

The best measurement of risk is cost incurred by the firm in case of an incident. Unfortunately, there are a lot of situations, in which such a cost is very hard to measure, as in case of company image and loss of potential orders. Nevertheless, each of the identified paths is burdened with risk of potential loss connected with improper access to resource.

Because we are not able to precisely determine the risk, one or a couple of methods of calculating risk should be used simultaneously, i.e. best case scenario, worst case scenario, most probable scenario.

Table 5. Points referring to risk (*source: self study*)

Risk level	No. of points	Description
High critical	5	Organization (system) loses ability to function. Serious economic results.
High	4	Organization (system) functions, but in each moment may lose this ability
Medium	3	Visible disruptions in company functioning.
Low	2	Minor obstruction of functioning, which rarely disrupt normal functioning
Low acceptable	1	Acceptable obstruction
None	0	System element which is irrelevant for the functioning of the whole system

In many cases, it will be enough just to calculate risk by attributing points, which refer to the greatness of this risk (Table 5). The table is based on a three-level

security mechanisms evaluation system, introduced by a certifying unit UOP (from European ITSEC). However, greater gradation of threats was introduced.

Having determined the level of losses, we can impose security measures on chosen system vulnerabilities, with regard to appropriate paths of access to resources (Figure 5). In this way, we set a new level of resources security. As we have calculated risk for each vulnerability, we can, in every moment, answer the question: What risk is left with regard to resources? Therefore, we are managing risk to resources. Lack of activity formalization in this method requires using trial-and-error method tests of the fact if level of risk is acceptable. It would be harder to reverse the problem, define the acceptable risk and try to find a set of security measures, especially in highly developed systems.

This method is satisfactory when we decide to secure all existing resource vulnerabilities. Sometimes it is impossible, and the level of security may vary as well. When looking for some more precisely determined level of risk, it is necessary to apply optimal choice of security measures method, which exceeds the scope of this paper.

8 Security in migration process

During the migration process, especially essential becomes the care for IT resources security. IT resources, which in normal work conditions are covered by security procedures, may unwillingly become endangered by threats in different system environment.

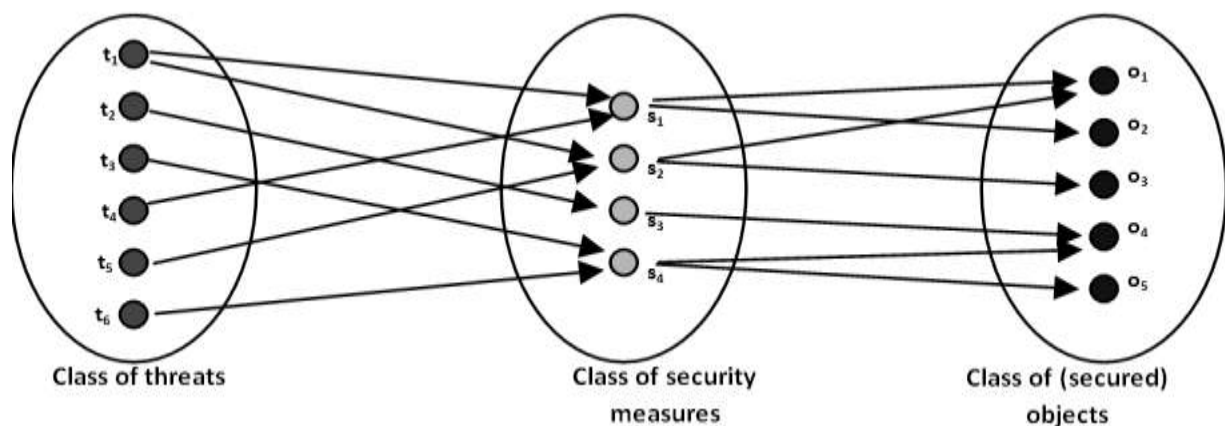

Figure 5 Complete security system (*source: self study*)

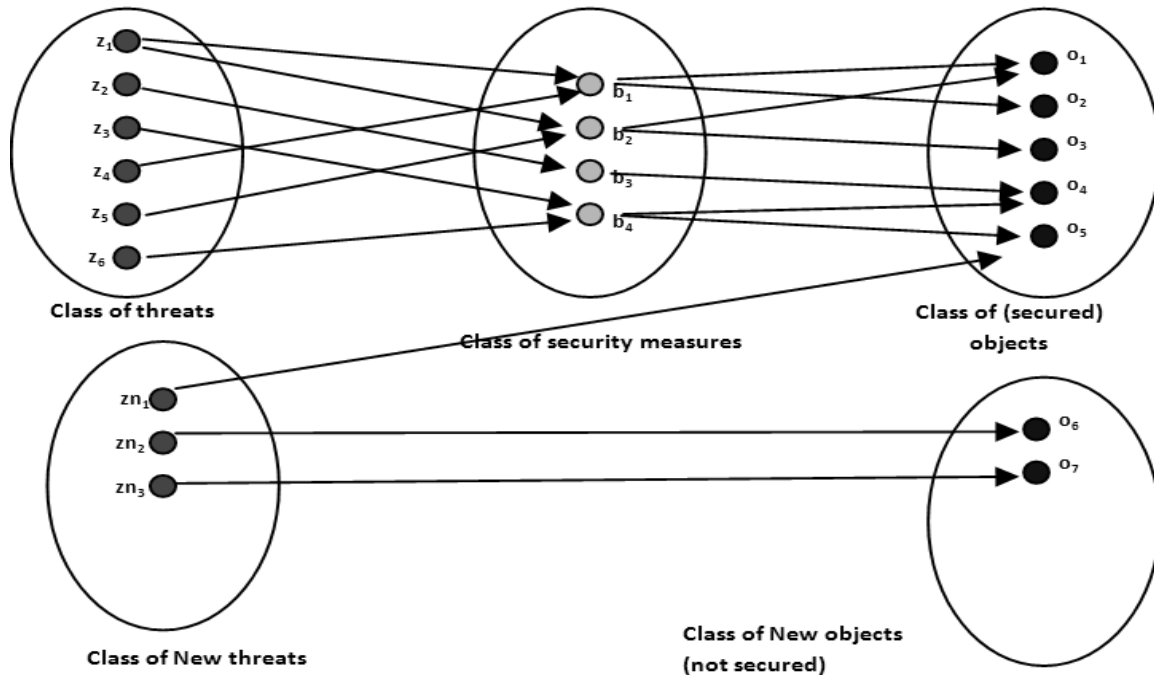

Figure 6. System during migration process
(source: self study)

8.1 Threats

During migration process, new threats appear which influence old resources (O1-O5 objects) as well as new resources (O6-O7 objects). In both cases, the interactions are not secured (see Figure 6).

Appropriate security action must introduce security measures for the purpose of resource protection. Below, exemplary threats which appear during migration process are described.

8.2 Additional accounts with higher system rights

Migration process is full of different types of tests and installations. For most actions, additional IT system accounts, often with too high rights, are added. Appropriate procedures and system rights structure may prevent interference of unauthorized persons with key system elements. Deleting such accounts must be attended to immediately after the process is finished.

8.3 Moving data

Process of moving data from source environment to target environment may be carried out according to the following schemes:

- directly between systems – original data may be damaged; it is necessary to prepare and test security copy in advance,
- moving of prepared data copy through chosen e-communication channels: http, ftp, e-mail – it is necessary to secure channel or data, i.e. by encrypting them,
- physical movement of data copy on a given storage device – it is necessary to secure data. i.e. by encrypting it and by physical protection during transport.

The above mentioned list implies the fact that we will have to cope with many versions of data copies, placed on different storage devices. Wrong choice of copy version, losing a copy or interception of a copy, i.e. on an old hard drive taken from a server which was put aside long ago, may all have serious legal and economic consequences.

8.4 Softening of security measures

Tight schedules of IT projects seem to be a good enough reason for softening the restrictions in the processes of granting rights or opening accounts. Certain administrative activities which improve system security are postponed for later periods and are often never executed.

8.5 Security systems shutdown

For the comfort of and in order to speed up some administrative and servicing activities, there will always exist the temptation to temporarily switch off chosen security systems. During migration process there are a lot of such activities, which may lead to prolonged periods of decreased threat-resistance. It is also more likely to leave systems without unsecured for a couple of days.

8.6 Remote access

Because of their systems' security, many companies do not allow direct connection with the internet. System migration is often handed over to external companies, which, for their own comfort, insist on the possibility of remote access.

If a company does not have proper infrastructure and experience to grant such an access, it can easily expose itself to trouble connected with data interception or network intruders. At this point, it is extremely important to introduce proper organizational and legal protection in the contract with the cooperating entity.

8.7 Hardware replacement

When one of elements of migration is hardware replacement, a problem appears of managing the used-up hardware. Scrapping, selling off to employees or utilizing do not lift the obligation to properly remove the data from the storage devices. Well known media cases of obtaining such data by journalists are the least severe punishment for this type of mistake.

8.8 New system break-in

As mentioned before, a newly introduced system is more vulnerable to all undesirable activities of third parties. Most common effects of breaking in are:

- introduction of changes to the attacked system (i.e. modification of password list, changing system software files),
- installation of modules such as Trojan horse or so called Sniffer,
- intrusion in private matters, i.e. reading someone else's e-mail,
- causing moral losses (i.e.: changing the content of web pages, distributing pornography).

8.9 Security

Gathered below are the most important protective factors, which improve security during migration:

- adequate procedures of system access, data access, moving and copying data; procedures which cover the entities which cooperate in migration process; appropriate legal protection in contracts with cooperating entities,
- physical protection: special control over all devices belonging to the key IT infrastructure elements of source and target environments (servers, switches, routers); installation of infrastructure in dedicated, air-conditioned, secure rooms,
- use of uninterruptable power supply: securing key IT infrastructure elements from instability or temporary lack of power supply; extremely important during installation of systems and moving data,
- use of uninterruptable power supply for air conditioning and back-up air conditioning; extremely important in server rooms with high power density,
- excluding target environment network from production infrastructure allows basic protection against unauthorized access,
- policy for creation of safety copies,
- policy for protection of security copies; storing, transporting and disposal,
- software updates: before launching system for production work it is necessary to take care of all software updates.

9 Other issues

Among other issues closely related to migration process technology and organization, version management for infrastructure elements, legal regulations and choice of appropriate organizational activities have to be pointed out.

9.1 Legal status

IT security, as mentioned before, is only one piece of information security of an organization. Organization operates in its specific legal environment. Legal regulations are also used in extraordinary company situations and everything has to be done to ensure that all actions are in line with these regulations.

9.2 Legal acts and regulations

Knowledge and use of detailed regulations for particular industries and chosen areas of company activity are obligatory. Nevertheless, this regulation do not impose specific solutions. Most of the time, they have organizational character.

For our considerations, from the legal acts mentioned below the ones of organizational character, which may be used in various ways, should be chosen. With regard to these acts, research of cost-optimal or minimum-loss solutions should be carried out:

- Banking Law,
- Accounting Standards,
- Personal Data Protection Act, 29 August 1997, Official Law Journal of 29 October 1997,
- Prime Minister's decree regarding fundamental security requirements of IT systems and networks of 25 February 1999, Official Law Journal No. 18, pos. 162,
- Confidential Information Protection Act,
- Electronic Signature Act,
- Copyrights Act,
- Act on protection of chosen electronic services based on conditional access.

9.3 Standards and normative acts

IT security is subject to standardization at different levels: international, regional, state and in different sectors of economy: military, banking, industrial, etc. Interconnections between standards and new standards raising from the others are natural processes. In case it is not regulated by separate law, it remains a dilemma, which standard should be considered most appropriate for particular solutions.

Examples shown below are an international standard and a methodology for IT system security management. Both examples have organizational character and, similarly as before, after elaboration of their formalized version may be used as elements of established methods of searching for optimal solutions:

- ISO/IEC 17799:2000 Standard,
- TISM methodology (Total Information Security Management).

9.4 Versioning

In the course of creation of IT solutions, starting from simple, independent applications, ending with complex, multi-module systems, the problem of proper version designation arises. In reality, every team has its own, elaborated system of application, module and documentation versioning. All the methods are based on similar rules. One of them is presented below⁷:

- version scheme:
 - <version number>—<version category>, where:
 - version number – series of digits and dots which designates version,
 - version category – additional attribute assigned to versions, which serve a special purpose,
- version number has its specific “sub-scheme”, which looks as follows:
 - <major>.<minor>.<path/build>,
 where major, minor and path/build are digits; the last element (path/build) may be omitted, if it equals 0 (zero):
 - major – this number characterizes a version, which, in comparison to the previous one, consists significant changes, which are not just “cosmetic” but are connected with important aspects of application functioning; it might be i.e. new way of client interface, new type of data exchange or whole new way of system functioning,
 - minor – this number designates introduction of new elements to application, which do not cause considerable changes in the whole application structure; it may be i.e. addition of new buttons or other elements, which, after contacting the client, led to changes aiming at improving application functionality,
 - patch/build – this number designates introduction of patch which fixes error/errors which were observed or program compilation number (incremented by compiler),
- version category – in order to ascribe an additional attribute to versions, specific categories are used:
 - develop (abbr. dev or d) – category for applications which are in development stage; accessible for a certain group of people (developers or trusted team members),

⁷ http://phppl.ezpublish.no/wortal/artykuly/pomysly_porady_sugestie_dobre_nawyki/wersjonowanie_aplikacji; Michał Golebiowski.

- alpha (abbr. a) – category for applications which went through a vote – was accepted by group of developers to undergo further tests performed by them,
- beta (abbr. b) – category meant for wider group of testers – project members who mainly deal with application testing,
- release candidate / release (abbr. rc or r) – category for applications meant for all the interested people; consists of smallest number of errors in comparison to the above mentioned categories; it is a partly finished project, with most possibilities of the final product; most of the times, such application is aimed at improving those elements, which are considered badly solved by the end user (program navigation, colors, etc.) and those errors, which were not observed earlier,
- final (abbr. f) – final version which goes to the client; this category is usually not added to the version; one can add additional number to category, such as rc 1, rc 2, which will denote another “sub-stage” in application versioning; the higher the number, the “faster” it comes to the next category (there is no upper limit in ascribing additional numbers, however they should not exceed 5).

Examples:

- 1.0 – first final version,
- 0.1-dev – application in development stage, which does not contain all the elements of “full” version,
- 2.2.43 – final application which contains certain corrections with regard to version 2.0 and patched loopholes,
- 1.0-rc – first version of application, which is intended for testing by people from outside.

10 Summary

Modern organization which operates within market economy uses a wide spectrum of information technologies both to run fundamental business activities and to support all kinds of internal processes. IT infrastructure is threatened by constant changes.

This article shows in a methodic way the approach which leads to IT system migration into new information environment. Weight of this issue cannot be overestimated in the situation, when after a few years or because of an organizational change, the company is forced to introduce fundamental changes to its IT system. In order to execute this activity effectively, it is

important always to adopt the informatization strategy – unfortunately, it is not a common phenomenon and hardly any organization systematically updates its business strategy and related informatization strategy.

IT system migration is always a serious threat to business continuity, from the point of view of business and information security. As mentioned in the beginning, the awareness of the company security issue is rising. Because the scope of services offered with the use of IT solutions, for supporting and running business, becomes bigger and bigger, IT security plays the key role with regard to business security. Consequently, market demand for introduction of the security policy, both for the period of changes and standard exploitation, increases.

Unfortunately, there is a certain shortage of methods which could support optimal choice of security measures for company resources. Finding fast and efficient methods of minimizing costs and risk can considerably accelerate improvement of security in many companies. At the same time, it can lead to faster company growth.

11 References

- [1] *Polish norm PN-I-13335-1:1999.*
- [2] Denning D.E. - *Information Warfare and Security.* Addison-Wesley, Massachusetts 1998.
- [3] Pipkin D.L. - *Information Security.* WN PWN, Warszawa 2002.
- [4] Krupa T. - *Projektowanie strategii informatyzacji* [in] *Przedsiębiorstwo w procesie globalizacji* (ed. T. Krupa). WNT, Warszawa 2001.
- [5] Krupa T. - *Zarządzanie informacją w zakładzie ubezpieczeń* [in] *Podstawy ubezpieczeń. t. III.* Przedsiębiorstwo (ed. J. Monkiewicz). Wyd Poltext, Warszawa 2003.
- [6] Pięta S. - *Metody doboru zabezpieczeń w systemach informatycznych* [in] *Komputerowo zintegrowane zarządzanie* (ed. R. Knosala). WNT, Warszawa 2003.
- [7] Pięta S. - *Metody doboru optymalnych zabezpieczeń informatycznych na potrzeby przedsiębiorstw* [in] *Informatyka w przedsiębiorstwie* (ed. T. Krupa). Oficyna Wydawnicza PW, Warszawa 2004.
- [8] Stokłosa J., Bilski T., Pankowski T. - *Bezpieczeństwo danych w systemach informatycznych.* WN PWN, Warszawa 2001.
- [9] Kifner T. - *Polityka Bezpieczeństwa i Ochrony Informacji.* Helion, Gliwice 1999.

- [10] Schneier B. - *Applied Cryptography*. Second Edition, John Wiley & Sons, New York 1996.
- [11] Molski M., Opala S. - *Elementarz bezpieczeństwa systemów informatycznych*. Mikom, Warszawa 2002.
- [12] DiS - *Migracje ERP 2005. MERP 2005*. Raport DiS. Warszawa 2005.
- [13] IANA - *Internet Assigned Numbers Authority*. <http://www.iana.org/>, June 2010.
- [14] ICANN - *Internet Corporation for Assigned Names and Numbers*. <http://www.icann.org/>, June 2010.
- [15] IFPUG - *International Function Point Users Group*. <http://www.ifpug.org/>, June 2010.
- [16] OGC - *PRINCE2*. http://www.ogc.gov.uk/methods_prince_2.asp, June 2010.
- [17] Project Management Institute - *A Guide to the Project Management Body of Knowledge*. Third Edition, Paperback PMI, PMBOK Books, Newton Square 2009.
- [18] Morimoto R., Noel M., Droubi O., Gardinier K., Neal N. - *Windows 2003 Server. Księga eksperta*. Helion, Gliwice 2004.

THE MULTICRITERIA ASSESSMENT METHODOLOGY OF THE DECISION SUPPORT SYSTEM IMPLEMENTATION EFFECTIVENESS

Lilianna WAŻNA*

Tadeusz KRUPA**

* Faculty of Economics and Management
University of Zielona Góra, 65-417 Zielona Góra, Poland
email: l.wazna@wez.uz.zgora.pl

**Faculty of Management
Warsaw University of Technology, 02-524 Warszawa, Poland
email: t.krupa@wz.pw.edu.pl

Abstract: The multi-criteria assessment methodology of implementation effectiveness of information systems illustrated by an example of decision support system (DSS) realized in w information technologies is presented in the article. The assessment of DSS under consideration takes place using the knowledge recorded in the form of fuzzy neural network, collected in an enterprise, on the basis of earlier realized implementations of other information systems. A model of retrieved DSS is expressed by means of a set of functionalities serving business processes of the enterprise under consideration. A model of implementation undertaking determined by means of a set of preparatory actions for the implementation and a set of directly implementation and exploitation actions is built for the retrieved DSS as well. Furthermore, a vector determining a current and planned implementation state of a set of DSS functionalities in the enterprise at time moments, before and after the commencement of planned implementation of the retrieved DSS is built. A concept of trapezoidal fuzzy numbers is used in building DSS models. An adjustment of fuzzy parameters of DSS models takes place by means of geometrical method of maximum absolute error points. A presented methodology enables to execute a multi-criteria effectiveness assessment of planned undertaking in relation to subjective criteria established by the enterprise (preferred time, cost and values of priority indexes). Additionally, the knowledge collected on the basis of earlier realized implementations of information systems and applied imprecise description of parameters taking into account errors made in their estimation in the past is used.

Keywords: decision support system, empirical knowledge base, prognostic decision, multi-criteria assessment methodology implementation effectiveness, decision making space model, uncertainty conditions, trapezoidal fuzzy numbers, fuzzy neural network, fuzzy reasoning.

1 Introduction

The multi-criteria assessment methodology of decision support system implementation effectiveness (MAM DSS IME) is adapted to making prognostic decisions concerning an assessment of effectiveness indexes which can be achieved by an enterprise in a process of DSS implementation in uncertainty conditions. The assessment takes place using the knowledge collected in the enterprise on the basis of earlier realized implementations of other information systems and recorded in the form of fuzzy neural network.

2 The essence of decision making space model

A structure of decision making space model used for the needs of the multi-criteria assessment methodology

of decision support system implementation effectiveness (MAM DSS IME) combines:

- DSS business functionalities,
- actions, costs and time of implementations,
- experience expressed by indexes of effects gained by the under consideration when implementing other systems,
- established budget for the implementation,
- time limit of achievement of preferred implementation effects determined by the enterprise.

A concept of trapezoidal fuzzy numbers is used in building the model. The fuzzy numbers give a possibility to represent a part of parameters determined imprecisely what allows to express and analyse uncertainty included in a description of elements of the whole implementation. A trapezoidal fuzzy number in the form

of $T_i = [T_{i_min}, T_{i_mL}, T_{i_mP}, T_{i_max}]$ describing a realization time limit is presented in Figure 1 as a description example of one of imprecisely determined parameters.

A scheme of decision making space model of DSS implementation effectiveness assessment is presented in Figure 2.

A DSS with functionalities (modules) $F = \{F_1, \dots, F_h\}$ serving business processes in the enterprise is given in the model, for example: $F = \{\text{Basic data, Sales and distribution, Purchases, Materials management, Production, Accountancy}\}$.

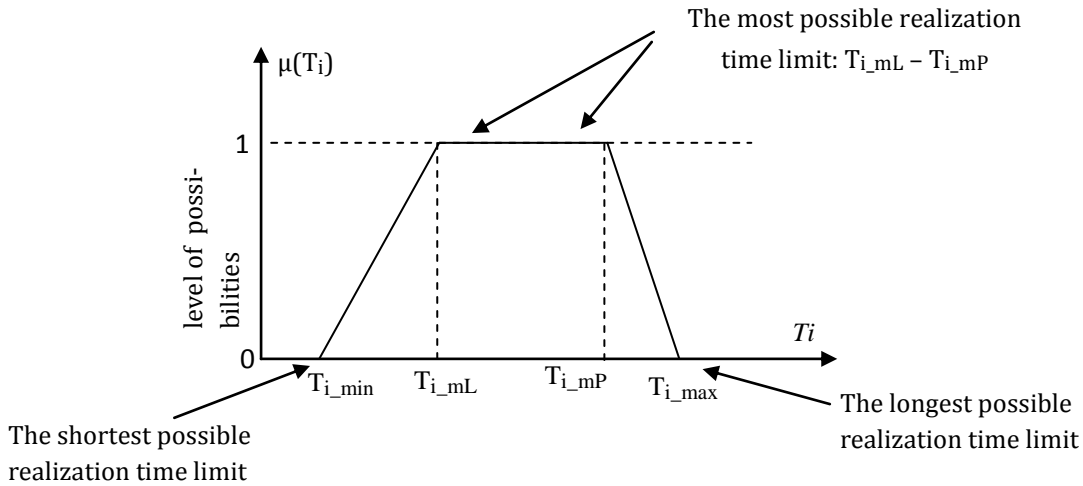

Figure 1. Realization time limit determined imprecisely by means of trapezoidal fuzzy number (source: self study)

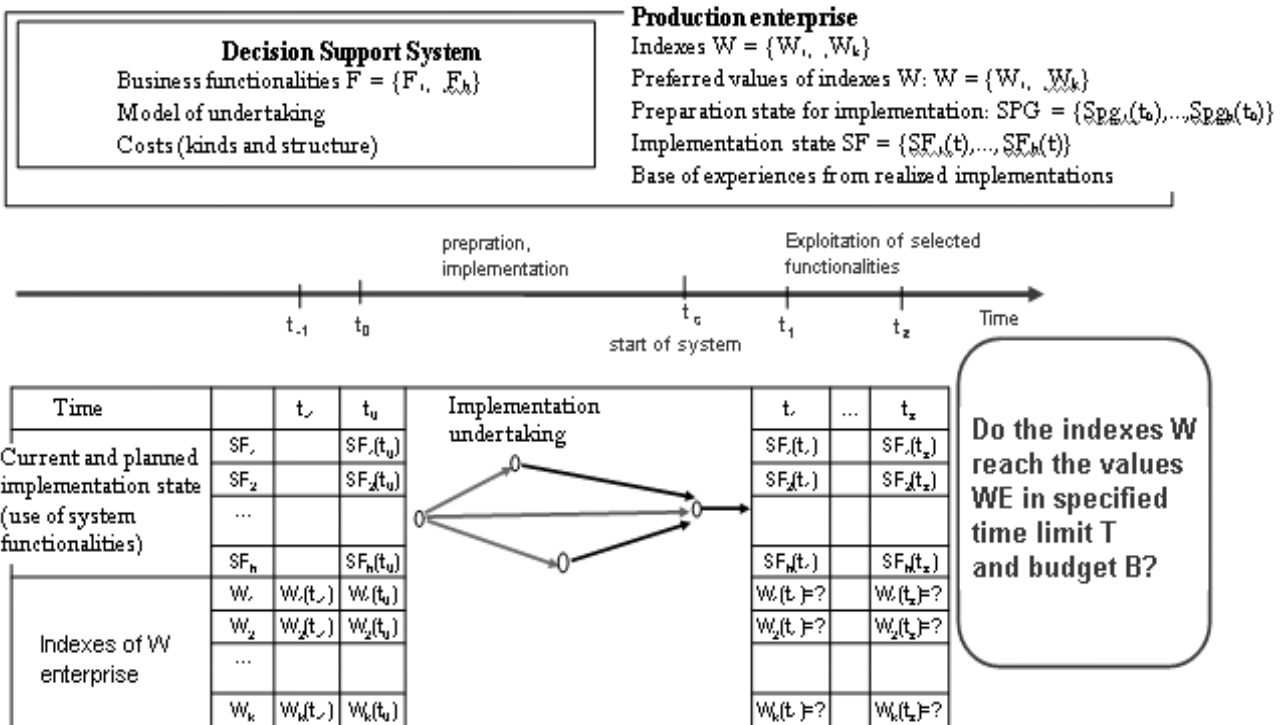

Figure 2. Decision making space model of DSS implementation effectiveness assessment (source: self study)

The information on the costs connected with the system implementation are given for a specified DSS; the costs include:

- cost of system licence KLC corresponding with a determined number of users,
- vector of types of costs of RK connected with a planned implementation,
- vector of fixed costs KST, determining the rates of fixed costs accordingly to every type of costs,
- vector of reference rates ODN, determining the rates of reference for every type of costs, constituting a base of estimation of variable costs,
- vector of values of reference rates WOD, determining the value of individual reference rates,
- vector of unit variable costs KZM, determining the rates of unit variable costs for every reference rate.

The exemplary information on a DSS implementation costs is presented in Table 1.

Table 1. Costs of DSS implementation undertaking – example
(source: self study)

RK	Types of costs	Fixed costs (% of licence costs) KST	Unit variable cost (% of fixed costs) KZM	Reference rate ODN	Value of reference rate WOD
rk ₁	Hardware (server)	[0, 0, 0, 0]%	[8, 9, 10, 12]%	Number of servers	0
rk ₂	Implementation service	[8, 9, 11, 12]%	[0,7; 0,8; 0,9; 1]	Number of person-days	[60, 65, 78, 80]
rk ₃	Trainings	[0, 0, 0, 0]%	[0,08; 0,1; 0,13; 0,14]%	Number of person-days	[55, 58, 60, 65]
rk ₄	System mainte- nance	[10, 12, 18, 25]%	[0, 0, 0, 0]%	-	[0, 0, 0, 0]

Table 2. DSS implementation undertaking model – example
(source: self study)

CPG	Preparatory actions	Event		Duration (days)	Preparatory state SPG
		start	end		
cp _{g1}	Preparation of test and development environment for configuration and development works	2	3	[14,16,20,21]	1
cp _{g2}	Training of the design team using a demonstrating version of the system	3	4	[24,26,30,32]	0
cp _{g3}	Protection of technical infrastructure - servers	2	4	[45,50,62,70]	1
cp _{g4}	Preparation of computer network with the users' computers	4	8	[50,55,70,80]	1
cp _{g5}	Preparation of the data	5	6	[44,48,50,60]	0
cp _{g6}	Data quality analysis	6	8	[14,16,21,25]	0
cp _{g7}	Reorganization	5	8	[21,23,35,40]	0
cp _{g8}	Training and control of final users	8	9	[8,9,12,14]	0
CWE	Implementation and exploitation actions				
cwe ₁	Planning of undertaking	1	2	[4,5,15,17]	
cwe ₂	Installation of the system	4	6	[12,14,15,16]	
cwe ₃	Modelling of process in the system with the participation of the design team	4	5	[14,16,18,20]	
cwe ₄	Taking-over of the data	6	7	[12,14,16,17]	
cwe ₅	Testing actions	7	8	[10,11,12,14]	
cwe ₆	Preparation of the system activation and start-up	9	10	[8,9,12,14]	

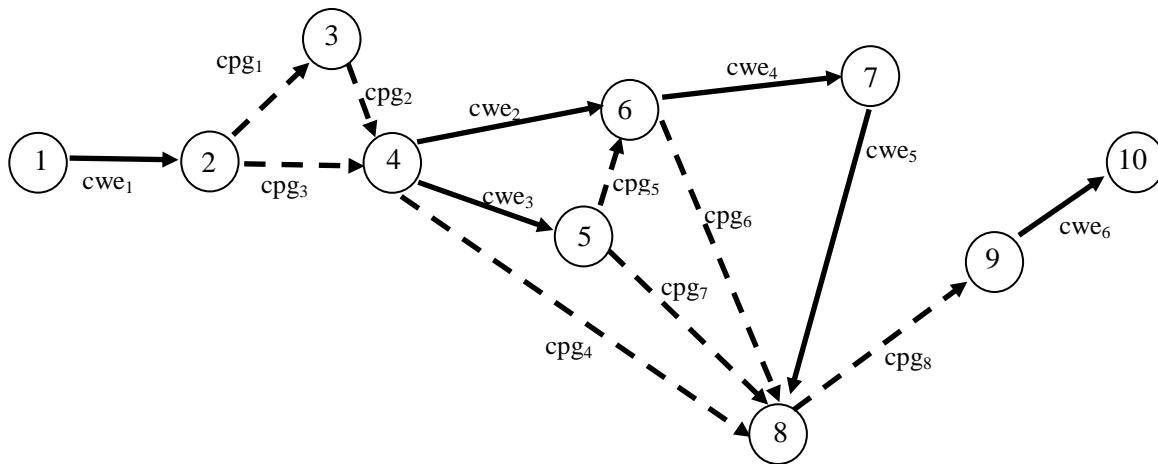

Figure 3. Implementation undertaking model – example
(source: self study)

Table 3. Values of indexes of the enterprise P before the commencement of DSS implementation – example
(source: self study)

	t_{-1}	t_0	Start	t_1	...	t_3
W_1	about 58 = [54,58,58,60]	about 67 = [63,67,67,69]		?	?	?
W_2	about 65 = [63,67,67,69]	about 72 = [70, 72,72,76]		?	?	?

An implementation undertaking model, determined by a set of preparatory actions for implementation CPG and implementation and exploitation actions CWE, connected with each other by means of technical, organizational and economical dependences, is given for every DSS under consideration as well. Every action is started and ended by an event and estimated duration determined imprecisely by means of fuzzy number is known for every action. An exemplary model of DSS implementation undertaking is presented in Table 2 and Figure 3.

Furthermore, an enterprise P considering an implementation of specified DSS is given.

A preparation state for the implementation SPG of the enterprise P before the commencement of implementation undertaking (moment t_0) whose is also shown in Table 1 is given for every preparatory action CPG. The preparation state of given preparatory action assumes the value 0 when the action is not yet executed, and the value 1 when the action is already executed. A time period which is needed to realize a planned implementation undertaking depends on the preparation state of the enterprise for the implementation.

A vector of indexes W, determining DSS implementation effects in the enterprise P is given, for example: $W = \{\text{delayed production orders (\% of realized orders),}$

overload (% - maximum value of appearing overload, to level of %)}, and the values of indexes W are known before the commencement of planned implementation undertaking of specified DSS (for time moments $t = t_{-1}, t_0$). An example of imprecisely determined values of indexes W of the enterprise before the commencement of DSS implementation is presented in Table 3.

Furthermore, a vector $SF(t) = \{SF_1(t), \dots, SF_h(t)\}$ determining a current and planned implementation state of functionalities $F = \{F_1, \dots, F_h\}$ of DSS in the enterprise P in the time moments $t = t_0, t_1, \dots, t_z$ is given, and its values before the commencement of planned implementation of specified DSS are known. An example of implementation state SF of DSS with the functionalities $F = \{F_1, F_2, F_3, F_4, F_5\} = \{\text{Basic data, Sales and distribution, Purchases, Materials management, Production}\}$ in the enterprise which plans to implement a functionality "Production" and uses other functionalities already is presented in Table 4.

A limited budget B of the enterprise P designed for the realization of planned implementation undertaking and time limit T, preferred by the enterprise P, related to the achievement of implementation undertaking effects of given DSS, within a specified exploitation period TE of this system is given as well.

Table 4. Current and planned implementation state SF of functionalities F in a selected enterprise – example (source: self study)

	t ₁	t ₀	Start	t ₁	t ₂	t ₃
SF ₁		1		1	1	1
SF ₂		1		1	1	1
SF ₃		1		1	1	1
SF ₄		1		1	1	1
SF ₅		0		1	1	1

A vector $WE = \{WE_1, \dots, WE_k\}$ (of target criteria) of values of indexes $W(t) = \{W_1(t), W_2(t), \dots, W_k(t)\}$ (for $t = TE$), preferred by the enterprise P, achieved after the implementation of specified DSS within a preferred time period T, with the system exploitation period TE is also given. Exemplary values of indexes $W = \{W_1, W_2\} = \{\text{delayed production orders (\% of realized orders)}, \text{overload (\% - maximum value of appearing overload, to level of \%)}\}$, preferred by the enterprise P, achieved as a result of DSS implementation, amounting accordingly to: $WE = \{WE_1, WE_2\} = \{\text{“to about 15\%”}, \text{“to about 10\%”}\}$ is presented in Figure 4.

The experience of the enterprise P gained on the basis of implementation of other systems of DSS class, expressed by the values of indexes determining the effects of given implementation is also given. A general representation of such information related to a single implementation is included in Table 5.

Exemplary data from several realized implementations are presented in Table 6.

3 The description of multi-criteria assessment methodology of implementation effectiveness

The multi-criteria assessment methodology of decision support system implementation effectiveness (MAM DSS IME) consists of the following stages:

- forecast of selected indexes of the enterprise from a DSS implementation on the basis of experiences from earlier executed implementations,
- forecast of implementation realization time and cost,
- multi-criteria assessment of DSS implementation effectiveness in relation to preferred target criteria.

Stage 1

The forecast of selected indexes of the enterprise from a DSS implementation takes place on the basis of the knowledge collected basing on earlier executed implementations. Therefore it is realized at two sub-stages:

1.1 first a base of empirical knowledge recorded in the form of fuzzy neural network, representing a fuzzy model of analysed reality, is formed,

1.2 then this base is used as a basis of forecasting, based on a fuzzy reasoning.

The forecast values of the enterprise’s indexes which a planned DSS implementation allows to reach within a specified time limit are a result of this stage.

Stage 1.1 The formation of empirical knowledge base

A formation of empirical knowledge base is to generalise collected information from earlier realized implementations of other systems.

The identification of existing rules between the data from previous periods t_{i-2}, t_{i-1} and a next period t_i , i.e. between the values of rates $W(t_{i-2}) SF(t_{i-1}) W(t_{i-1}) SF(t_i)$ and the values of indexes $W(t_i)$ for $i = 1, \dots, z$ is carried out on the basis of collected measurement data whose example is shown in Table 6. Table 7 presents the data from Table 6 prepared for the identification of modelled dependence rules.

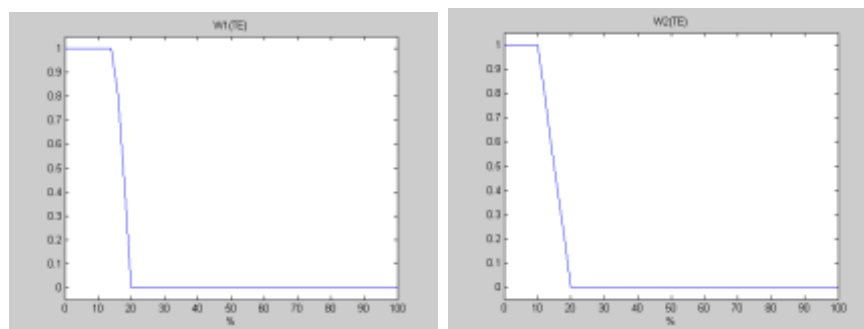

Figure 4. Values WE of indexes W, preferred by the enterprise, resulting from DSS implementation (source: self study)

Table 5. Representation of implementation state of DSS functionalities and indexes of given enterprise
(source: self study)

Time		t_{-1}	t_0	t_1	...	t_z
Implementation state of DSS functionalities	SF ₁		SF ₁ (t_0)	SF ₁ (t_1)		SF ₁ (t_z)
	SF ₂		SF ₂ (t_0)	SF ₂ (t_1)		SF ₂ (t_z)
	...					
	SF _h		SF _h (t_0)	SF _h (t_1)		SF _h (t_z)
Indexes of enterprise	W ₁	W ₁ (t_{-1})	W ₁ (t_0)	W ₁ (t_1)		W ₁ (t_z)
	W ₂	W ₂ (t_{-1})	W ₂ (t_0)	W ₂ (t_1)		W ₂ (t_z)
	...					
	W _k	W _k (t_{-1})	W _k (t_0)	W _k (t_1)		W _k (t_z)

Table 6. Exemplary data from realized implementations of systems of DSS class
(source: self study)

	Implementation 1					Implementation 2				
	t_{-1}	t_0	t_1	t_2	t_3	t_{-1}	t_0	t_1	t_2	t_3
SF ₁		1	1	1	1		1	1	1	1
SF ₂		0	1	1	1		0	1	1	1
SF ₃		0	0	1	1		0	0	0	1
W ₁	60%	70%	30%	20%	18%	78%	72%	27%	25%	22%
W ₂	90%	80%	35%	25%	24%	60%	68%	18%	15%	12%
	Implementation 3					Implementation 4				
	t_{-1}	t_0	t_1	t_2	t_3	t_{-1}	t_0	t_1	t_2	t_3
SF ₁		1	1	1	1		1	1	1	1
SF ₂		0	1	1	1		0	1	1	1
SF ₃		0	0	0	1		0	0	1	1
W ₁	55%	63%	34%	31%	26%	50%	65%	26%	15%	16%
W ₂	71%	82%	31%	27%	17%	70%	60%	18%	10%	8%

Table 7. Measurement data prepared for modelling. Source: authors' own research
(source: self study)

	Implementation 1			Implementation 2			Implementation 3			Implementation 4		
W ₁ (t_{i-2})	0,60	0,70	0,30	0,78	0,72	0,27	0,55	0,63	0,34	0,50	0,65	0,26
W ₂ (t_{i-2})	0,90	0,80	0,35	0,60	0,68	0,18	0,71	0,82	0,31	0,70	0,60	0,18
SF ₁ (t_{i-1})	1	1	1	1	1	1	1	1	1	1	1	1
SF ₂ (t_{i-1})	0	1	1	0	1	1	0	1	1	0	1	1
SF ₃ (t_{i-1})	0	0	1	0	0	0	0	0	0	0	0	1
W ₁ (t_{i-1})	0,70	0,30	0,20	0,72	0,27	0,25	0,63	0,34	0,31	0,65	0,26	0,15
W ₂ (t_{i-1})	0,80	0,35	0,25	0,68	0,18	0,15	0,82	0,31	0,27	0,60	0,18	0,10
SF ₁ (t_i)	1	1	1	1	1	1	1	1	1	1	1	1
SF ₂ (t_i)	1	1	1	1	1	1	1	1	1	1	1	1
SF ₃ (t_i)	0	1	1	0	0	1	0	0	1	0	1	1
W ₁ (t_i)	0,30	0,20	0,18	0,27	0,25	0,22	0,34	0,31	0,26	0,26	0,15	0,16
W ₂ (t_i)	0,35	0,25	0,24	0,18	0,15	0,12	0,31	0,27	0,17	0,18	0,10	0,08

Stage 1.1 – Step 1 The filtration of measurement samples by means of fuzzy average diagram method

The filtration of measurement samples of modelled system input/output lies in the determination of essential inputs of the model by means of below-discussed method of fuzzy average diagrams prepared by Lin and Cunningham (see [3], [4]).

All measurement samples are projected on planes of particular input variables for every output variable. Then a weighted average for any section of given input variable on the basis of measurement samples of the nearest neighbourhood using a Gaussian affinity function according to the formula (1) is calculated.

If a value of output variable depends on an input variable, then the average in sections changes. The higher dependence of output variable on a given input variable, the bigger scope of average value variability for analysed sections.

$$y_{sr}(x) = \frac{\sum_{k=1}^m \mu(x_k) y_k}{\sum_{k=1}^m \mu(x_k)} = \frac{\sum_{k=1}^m \exp\left(-\left(\frac{x_k - x}{b}\right)^2\right) y_k}{\sum_{k=1}^m \exp\left(-\left(\frac{x_k - x}{b}\right)^2\right)} \quad (1)$$

where:

x – input variable,

y – output variable,

k – number of measurement point,

b – width of neighbourhood scope in section points.

A parameter b equal to 10% of variability scope of given input variable is assumed in the study. For example, for the data from Table 7 in case of input variable $W_1(t_{i-2}) = x$ and output variable $W_1(t_i) = y$, the

parameter b is $b = 10\%(0,78 - 0,26) = 0,052$ and the determination of average value y_{av} in the point 0,6 is presented in Table 8.

The values of the average y_{av} determined in other measurement points are included in Table 9. On the basis of the data from Table 9 it can be noticed that a scope of section average variability in this case is equal to $\Delta y_{av} = 0,31 - 0,19 = 0,12$.

After the filtration for other measurement data from Table 7, executed by means of proposed method, there are obtained the results included in Table 10 from which it results that the variables marked as: $x_1, x_2, x_3, x_4, x_5, x_6, x_7$ are essential inputs for modelling.

The measurement data, obtained as a result of this stage, prepared for modelling the dependence between output variables (y_1, y_2) and input variables (x_1, \dots, x_7), are presented in Table 11.

Stage 1.1 – Step 2 The self-organization and adjustment of fuzzy model parameters by a geometrical method of maximum absolute error points

In this step the measurement data of the most important elements of fuzzy model structure which include: rule base and number of fuzzy sets assigned to individual inputs and outputs of the model are determined on the basis of the data prepared in the step 1. For this purpose it is used a modelling algorithm by the method of maximum error point (see Piegat 1999, Piegat 2001) whose conduct course is presented below on the basis of simplified example of modelling of the function for which the measurement data included in Table 12 are known.

Table 8. Determination of average value $y_{av}(0,6)$

(source: self study)

x	0,6	0,7	0,3	0,78	0,72	0,27	0,55	0,63	0,34	0,5	0,65	0,26	
y	0,3	0,2	0,18	0,27	0,25	0,22	0,34	0,31	0,26	0,26	0,15	0,16	total
$\mu(x_k)$	1	0,025	0	0	0	0	0,40	0,72	0	0,02	0,40	0	2,56
$\mu(x_k)y_k$	0,3	0,005	0	0	0	0	0,13	0,22	0	0,01	0,06	0	0,73
												y_{av}	0,28

Table 9. Determination of average value y_{av} in measurement points x_1

(source: self study)

x_1	0,6	0,7	0,3	0,78	0,72	0,27	0,55	0,63	0,34	0,5	0,65	0,26
y_1	0,3	0,2	0,18	0,27	0,25	0,22	0,34	0,31	0,26	0,26	0,15	0,16
y_{sr}	0,28	0,22	0,20	0,26	0,23	0,19	0,31	0,25	0,23	0,28	0,23	0,19

Table 10. Results of filtration by means of fuzzy average diagram method for the data from Table 7
(source: self study)

	Δy_{jav}		Essential variables
	$W_1(t_i) = y_1$	$W_2(t_i) = y_2$	input
$W_1(t_{i-2})$	0,1212	0,1547	x_1
$W_2(t_{i-2})$	0,1006	0,2220	x_2
$SF_1(t_{i-1})$	0	0	-
$SF_2(t_{i-1})$	0,0763	0,0825	x_3
$SF_3(t_{i-1})$	0,0860	0,0480	x_4
$W_1(t_{i-1})$	0,1326	0,1273	x_5
$W_2(t_{i-1})$	0,1327	0,2234	x_6
$SF_1(t_i)$	0	0	-
$SF_2(t_i)$	0	0	-
$SF_3(t_i)$	0,0933	0,0800	x_7

Table 11. Measurement data from Table 7 after filtration
(source: self study)

		Implementation 1			Implementation 2			Implementation 3			Implementation 4		
x_1	$W_1(t_{i-2})$	0,60	0,70	0,30	0,78	0,72	0,27	0,55	0,63	0,34	0,50	0,65	0,26
x_2	$W_2(t_{i-2})$	0,90	0,80	0,35	0,60	0,68	0,18	0,71	0,82	0,31	0,70	0,60	0,18
x_3	$SF_2(t_{i-1})$	0	1	1	0	1	1	0	1	1	0	1	1
x_4	$SF_3(t_{i-1})$	0	0	1	0	0	0	0	0	0	0	0	1
x_5	$W_1(t_{i-1})$	0,70	0,30	0,20	0,72	0,27	0,25	0,63	0,34	0,31	0,65	0,26	0,15
x_6	$W_2(t_{i-1})$	0,80	0,35	0,25	0,68	0,18	0,15	0,82	0,31	0,27	0,60	0,18	0,10
x_7	$SF_3(t_i)$	0	1	1	0	0	1	0	0	1	0	1	1
y_1	$W_1(t_i)$	0,30	0,20	0,18	0,27	0,25	0,22	0,34	0,31	0,26	0,26	0,15	0,16
y_2	$W_2(t_i)$	0,35	0,25	0,24	0,18	0,15	0,12	0,31	0,27	0,17	0,18	0,10	0,08

Table 12. Exemplary measurement data of function $y_1=x_1^2$
(source: self study)

x_1	-2	-1,7	-1,4	-1,1	-0,8	-0,5	-0,2	0,1	0,4	0,7	1	1,3	1,6	1,9
y_1	4	2,89	1,96	1,21	0,64	0,25	0,04	0,01	0,16	0,49	1	1,69	2,56	3,61

A The determination of base model M_0 by a method of exit beyond the space of considerations

In case of n input variables, a base model which constitutes the most rough generalization of modelled dependence takes a form of hypertetrahedral model of $n+1$ rules. In case of three input variables, this model is reduced to the tetrahedral space placed in Figure 5 with four rules placed in the points P_1, \dots, P_4 .

In case of two input variables, it has a triangular form, and in case of one input variable x_1 it is sufficient to place the rules in measurement points of minimum and maximum value of this input variable, i.e. for an example of the data from Table 12 in the points of $x_1 = -2$ and $x_1 = 1,9$.

The values of output variable are established at random at this stage, therefore the points for the initial rules of the example under consideration are: $(-2; 0,01)$ and $(1,9; 4)$. These points determine the parameters of affinity function of input x_1 , assumed in the base model, which are shown in Figure 6a) ($a_{11} = -2, a_{12} = 1,9$), and the parameters of affinity function of output y_1 , which are shown in Figure 6b) ($y_{B11} = 0,01, y_{B21} = 4$).

It is assumed that the inference is performed using an operator of PROD implication, and defuzzification is performed by means of height method (using singletons placed on vertices of affinity function) in the base model.

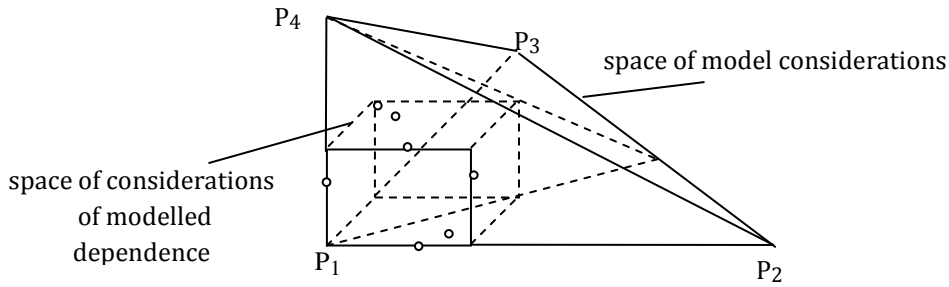

Figure 5. Exit beyond the space of considerations – example for three input variables
(source: self study)

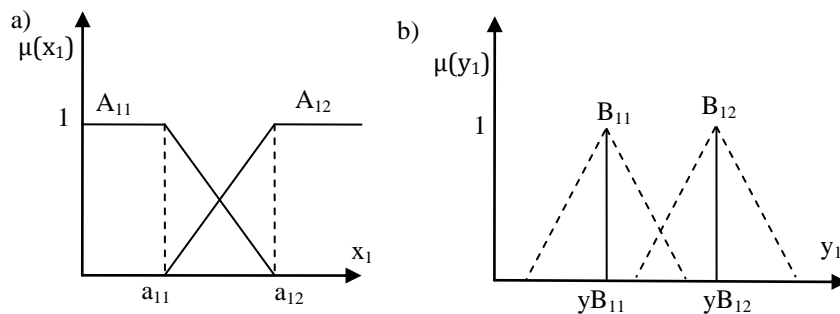

Figure 6. Affinity functions of fuzzy model
(source: self study)

B A fuzzy neural network representing a base model for the case of three input variables and two output variables is presented in Figure 7

In an analysed example with one input variable and one output variable, this network is reduced to the input x_1 and output y_1 . In the course of training of neural network, the parameters of affinity function of model outputs are subject to the adjustment, therefore in the example under consideration there are the parameters y_{B11} and y_{B21} .

The adjustment, discussed below more precisely, is executed according to the rule of error back propagation and gradient methods. It consists in such a gradual change of parameters adjusted on the basis of measurement data which leads to the minimization of a criterion which is an accumulated squared error. A set of training samples and a set of test samples is separated among all measurement samples. The samples are divided randomly in the ration of 2 to 1.

For every measurement g from the set of training data there are calculated a value of model output $y_{M0}(g)$ and error:

$$e_g = y_g - y_{M0}(g) \tag{2}$$

The accumulated squared error of the network for the whole training cycle (epoch) with k output variables is equal to:

$$E = \begin{bmatrix} E_1 \\ \vdots \\ E_k \end{bmatrix} = 0,5 \begin{bmatrix} \sum_g e_1(g)^2 \\ \vdots \\ \sum_g e_k(g)^2 \end{bmatrix} \tag{3}$$

The impact of adjusted parameter $y_{Bij}(g)$ ($i = 1, \dots, n+1$ $j = 1, \dots, k$, n - number of input variables, k - number of output variables) in the step g on an error of the network depends on a derivate $\partial 0,5(e_j(g))^2 / \partial y_{Bij}(g)$. To bring a parameter closer to its optimum value it is moved in the direction of a negative gradient by the value $\Delta y_{Bij}(g+1)$ expressed by the formula:

$$\Delta y_{Bij}(g+1) = -0,5\alpha \frac{\partial 0,5(e_j(g))^2}{\partial y_{Bij}(g)} \tag{4}$$

where:

α – training speed coefficient.

A new value of parameter $y_{Bij}(g+1)$ is calculated on the basis of the formula

$$y_{Bij}(g+1) = y_{Bij}(g) + \Delta y_{Bij}(g+1) = y_{Bij}(g) - 0,5\alpha \frac{\partial 0,5(e_j(g))^2}{\partial y_{Bij}(g)} \quad (5)$$

where:

$$\frac{\partial 0,5(e_j(g))^2}{\partial y_{Bij}(g)} = \frac{-\mu_{Bi}(g)}{\mu_{B1}(g) + \dots + \mu_{Bn+1}(g)} e_j(g) \quad (6)$$

The network is trained on the basis of training data, then an average absolute error is determined on the basis of test data, and after the execution of a series

of experiments, these values of adjusted parameters are selected with which the error on the test data is the least.

Going back to the analysed example related to the data from Table 12, a division into training data and test data, shown in Table 13, is assumed in this study.

As a result of executed experiments with such an assumed division of measurement data, the values of adjusted parameters $y_{B11} = 2,8022$ $y_{B21} = 0,7703$ with an average absolute error on the training data $avE_{0u} = 1,5565$, and on the test data $avE_{0t} = 0,7066$ are obtained.

Table 13. Division of measurement data from Table 12 into training data (x_{1u}, y_{1u}) and test data (x_{1t}, y_{1t}) (source: self study)

x_{1u}	-2,00	-1,40	-1,10	-0,50	-0,20	0,10	0,40	1,60	1,90
y_{1u}	4,00	1,96	1,21	0,25	0,04	0,01	0,16	2,56	3,61
x_{1t}	-1,70	-0,80	0,70	1,00	1,30				
y_{1t}	2,89	0,64	0,49	1,00	1,69				

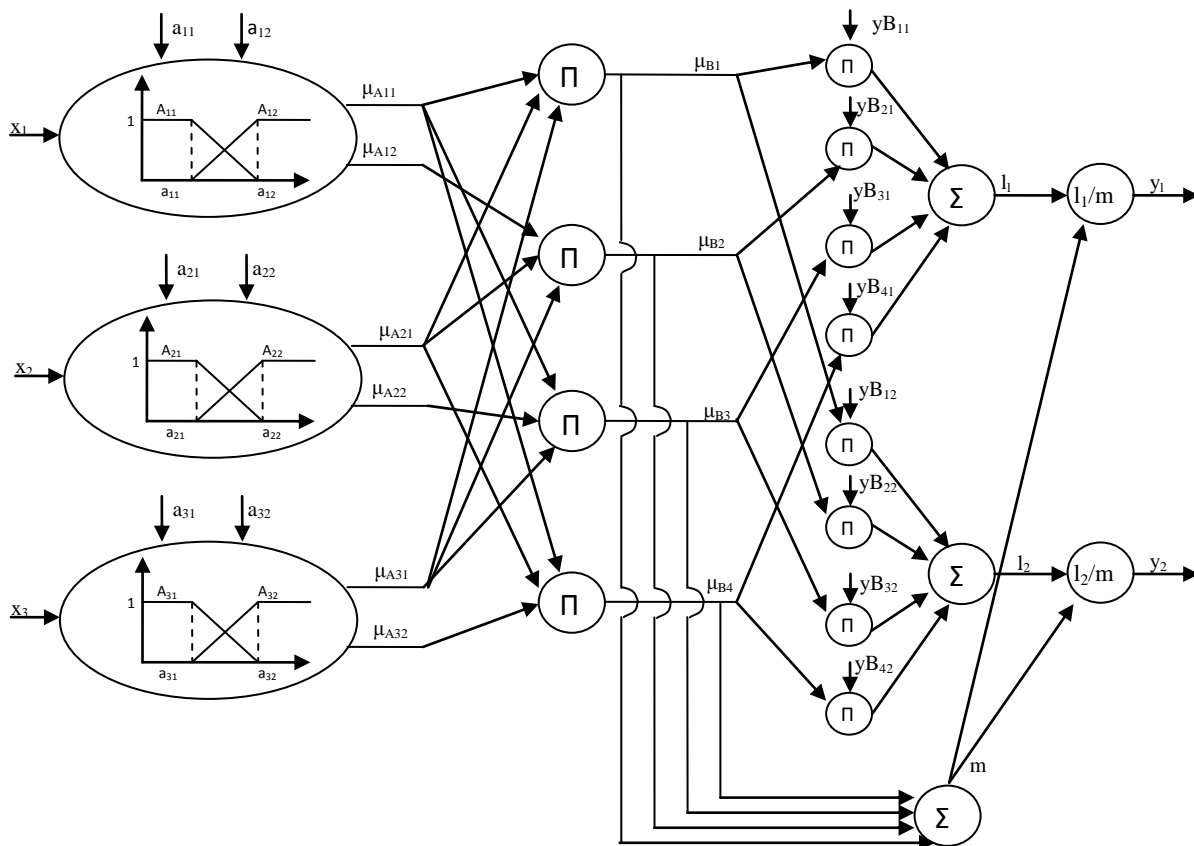

Figure 7. Fuzzy neural network representing a base model (source: self study)

Table 14. Base model error
(source: self study)

x_1u	-2,0000	-1,4000	-1,1000	-0,5000	-0,2000	0,1000	0,4000	1,6000	1,9000
y_1u	4,0000	1,9600	1,2100	0,2500	0,0400	0,0100	0,1600	2,5600	3,6100
$y_{1M_0}u$	2,8022	2,4896	2,3333	2,0207	1,8644	1,7081	1,5518	0,9266	0,7703
$E_0 u$	1,1978	-0,5296	-1,1233	-1,7707	-1,8244	-1,6981	-1,3918	1,6334	2,8397

C The determination of base model error E_0

In case of sufficient precision – completion of modelling, otherwise – continuation of modelling (stage D – modelling of error E_0). The precision of base model M_0 is controlled by comparing output values of the model and measurement data. The base model error $E_0u = y_1u - y_{1M_0}u$ is shown in Table 14. The average absolute error:

$$avE_0u = \sum_{i=1}^9 |E_0u_i| / 9 = 1,5565$$

Modelling was continued going to the stage D.

D Placing 2 rules in points of the extreme of base model error E_0 – model of error E_{0M}

When the error E_0 is determined, there are placed additional rules in the points of the extreme (visible in Table 14), i.e. in the points: $(1,9; 2,8397) = (m_{11}^1, e_{0max1})$ and $(-0,2; -1,8244) = (m_{12}^1, e_{0min1})$.

E The adjustment of affinity function parameters of error model E_{0M} on the basis of samples of base model error E_0

The error is modelled by the affinity functions of the form (7), shown in Figure 8.

$$\mu_{AEIs}^1(x_1) = \exp\left(-\left|\frac{x_1 - m_{1s}^1}{\delta_{1s}^1}\right|^{I_{1s}^1}\right) \quad s = 1,2 \quad (7)$$

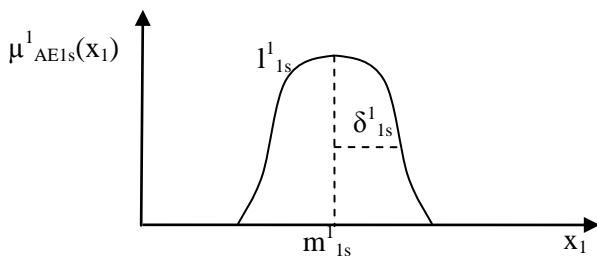

Figure 8. Affinity function for modelling the error E_0 ($s = \{1, 2\}$) (source: self study)

The parameters $m_{11}^1 = 1,9$ and $m_{12}^1 = -0,2$ are determined by coordinates of the points selected at the stage D in which the rules are placed. The parameters $\delta_{11}^1, \delta_{12}^1, I_{11}^1, I_{12}^1$ are adjusted by means of fuzzy neural

network whose form for three input variables and output variable y_i is included in Figure 9 (value 1 is assumed for the output variable y_{1i}).

The adjustment takes place on the basis of error samples E_0u visible in Table 14 and it is executed according to the error back propagation described at the stage B and gradient methods. After the execution of a series of experiments, the following values of adjusted parameters are assumed in the case under consideration: $\delta_{11}^1 = 0,5138, I_{11}^1 = 1,5496, \delta_{12}^1 = 1,1077, I_{12}^1 = 2,3234$ with an average absolute error on the training data $avE_{0M}u = 0,1808$, and on the test data $avE_{0M}t = 0,1361$.

F The formation of model M_1 (sum of M_0 and E_{0M})

In case of sufficient precision – completion of modelling, otherwise – determination of error residuum E_1 and continuation of modelling till a satisfying precision is achieved. The base model M_0 is added to the error model E_{0M} . Their sum forms a model M_1 . The error model E_{0M} is subtracted from the error E_0 of base model and the residuum of error E_1 is achieved. The output of error model E_{0M} obtained at the stage E and the residuum of error $E_1 = E_0 - E_{0M}$ for the training data considered in the example is presented Table 15. Average absolute error:

$$avE_1u = \sum_{i=1}^9 |E_1u_i| / 9 = 0,1796$$

If an average absolute error of the residuum is not appropriately small, then a next fuzzy model of error residuum E_{1M} is formed and added to the previous models increasing its accumulated precision. In the case under consideration for the achieved model M_1 an average absolute error on the training data is equal to 0,1796, and on the test data is equal to 0,1482. The output of the model $M_1 = M_0 + E_{0M}$ and error of this model equal to the residuum of the error E_1 is presented in Table 16.

Because a precision of the model M_1 established in the example is considered as insufficient, the modelling of error residuum E_1 is continued according to the rules

described at the stages D – F. It means that the model of error residuum E_1 is formed on the basis of the data listed in Table 17 together with placing the next rules in the points of extreme visible in Table: (-2; 1,2434) and (-1,1; -0,2067).

A described procedure (stages D – E) was repeated for times achieving an average absolute error on the training data 0,0127, an on the test data 0,0696. The parameters of retrieved fuzzy model established at the next stages are presented in Table 18.

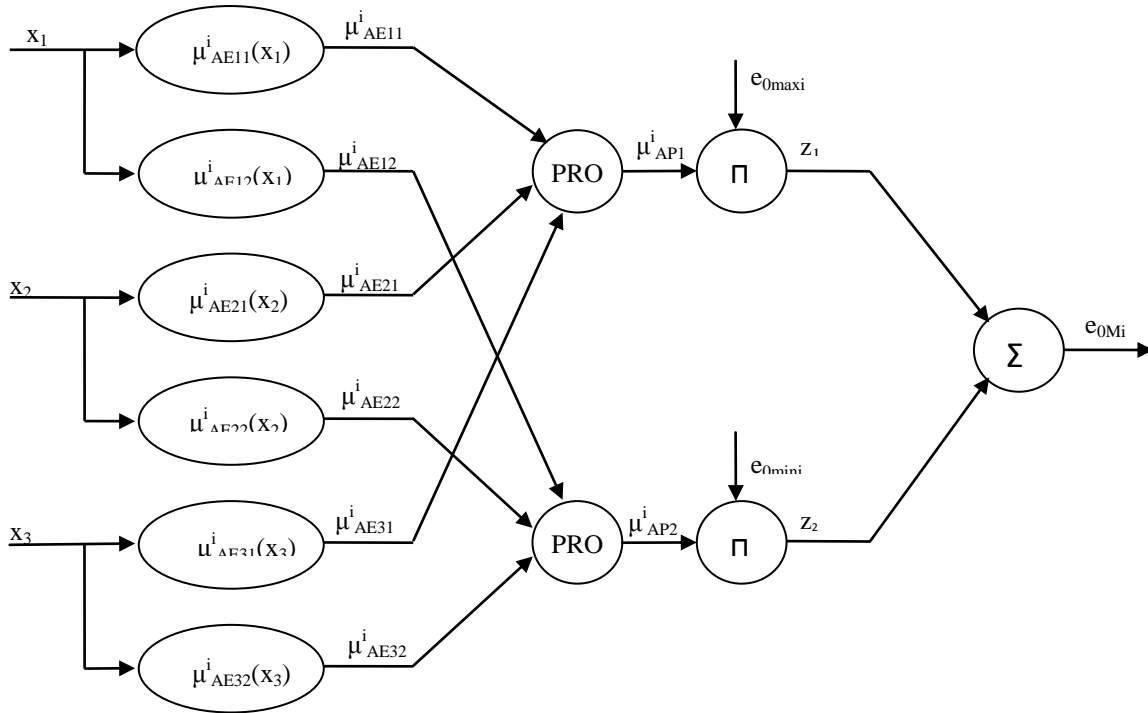

Figure 9. Fuzzy neural network for modelling the error E_0
(source: self study)

Table 15. Model output E_{0M} and error residuum E_1
(source: self study)

x_1u	-2,0000	-1,4000	-1,1000	-0,5000	-0,2000	0,1000	0,4000	1,6000	1,9000
$E_0 u$	1,1978	-0,5296	-1,1233	-1,7707	-1,8244	-1,6981	-1,3918	1,6334	2,8397
$E_{0M} u$	-0,0456	-0,4582	-0,9166	-1,7378	-1,8208	-1,7267	-1,3715	1,6321	2,8311
$E_1 u$	1,2434	-0,0714	-0,2067	-0,0329	-0,0036	0,0286	-0,0203	0,0013	0,0086

Table 16. Output and error of the model $M_1 = M_0 + E_{0M}$
(source: self study)

x_1u	-2,0000	-1,4000	-1,1000	-0,5000	-0,2000	0,1000	0,4000	1,6000	1,9000
y_1u	4,0000	1,9600	1,2100	0,2500	0,0400	0,0100	0,1600	2,5600	3,6100
$y_{1M0}u$	2,8022	2,4896	2,3333	2,0207	1,8644	1,7081	1,5518	0,9266	0,7703
$E_{0M}u$	-0,0456	-0,4582	-0,9166	-1,7378	-1,8208	-1,7267	-1,3715	1,6321	2,8311
$y_{1M1}u$	2,7566	2,0314	1,4167	0,2829	0,0436	-0,0186	0,1803	2,5587	3,6014
E_1u	1,2434	-0,0714	-0,2067	-0,0329	-0,0036	0,0286	-0,0203	0,0013	0,0086

Table 17. Output and error of the model $M_1 = M_0 + E_{0M}$
(source: self study)

x_1u	-2	-1,4	-1,1	-0,5	-0,2	0,1	0,4	1,6	1,9
E_1u	1,2434	-0,0714	-0,2067	-0,0329	-0,0036	0,0286	-0,0203	0,0013	0,0086

Table 18. Parameters of established fuzzy model on the basis of the data from Table 12
(source: self study)

	a_{11}	a_{12}	yB_{11}	yB_{21}			avE_{0u}	avE_{0t}
M_0	-2,0000	1,9000	2,8022	0,7703			1,5567	0,7066
	m^1_{11}	δ^1_{11}	l^1_{11}	m^1_{12}	δ^1_{12}	l^1_{12}		
E_{0M}	1,9000	0,4905	1,3058	-0,2000	1,0501	2,4223	0,1796	0,1482
E_{1M}	-2,0000	0,2441	1,7382	-1,1000	0,2389	0,6757	0,0130	0,0818
E_{2M}	0,1000	0,5173	7,3531	-1,4000	0,0890	0,0530	0,0120	0,0803
E_{3M}	-2,0000	0,6821	5,5034	0,4000	0,9634	7,7719	0,0127	0,0696

Stage 1.2 Fuzzy reasoning

A fuzzy model formed according to the stage 1.1 constitutes an empirical knowledge base which is utilized for the forecasting based on a fuzzy reasoning. Having the data on a current (at the moment t_0) and planned (at the moments t_1, \dots, t_z) implementation state of functionalities SF of the DSS under consideration in a given enterprise and known values of selected indexes W of this enterprise before the implementation (at the moments t_{-1} and t_0), a forecast of these indexes in subsequent periods t_1, \dots, t_z is determined after the start of the implementation.

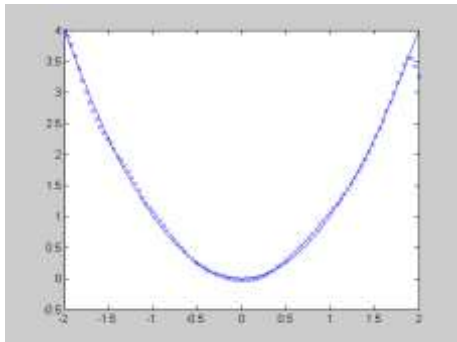

Figure 10. Results of fuzzy reasoning by means of fuzzy model with parameters from Table 18 for $x_1 = \{-2; -1,96; \dots; 1,92; 1,96; 2\}$.
(source: self study)

A retrieval of forecast values boils down to the determination of values of output variables on the basis of the data of values of input variables by means of fuzzy model recorded in the form of fuzzy neural network with parameters established at the stage 1.1. In case of exemplary fuzzy model, determined at the stage 1.1 whose parameters are listed in Table 18, the values of output variable y_1 for the exemplary selected values of input variable $x_1 = \{-2; -1,96; -1,92; \dots; 1,92; 1,96; 2\}$ were retrieved. The achieved results are presented in Figure 10 (for comparison: diagram of function $y_1 = x_1^2$ is marked by a solid line).

An exemplary fuzzy value of input variable $x_1 = [0,4 \ 0,5 \ 0,5 \ 0,7]$ and forecast fuzzy value of output variable y_1 , corresponding with it, achieved using a model with the parameters from Table 18 is presented in Figure 11.

Stage 2

Stage 2 concerns a forecast of DSS implementation realization time and cost and it is realized at two sub-stages:

- 2.1 forecast of DSS implementation time taking into account a preparation state of the enterprise,
- 2.2 forecast of DSS implementation cost.

Stage 2.1 The forecast of DSS implementation time

The information on the time which is necessary to implement the DSS taking into account a current preparation state of enterprise P for the implementation is a result of this stage. A conduct procedure is presented on the basis of an example described below.

A model of implementation undertaking, presented in Figure 3 with a separation of preparatory actions – listed in Table 2 – for the implementation CPG, and implementation and exploitation actions CWE for which estimated durations of actions CPG and durations of actions CWE determined imprecisely by means of trapezoidal fuzzy numbers are known, is given for a specified DSS. A preparation state – visible in Table 2 – for the implementation of specified enterprise in relation to individual preparatory actions of the undertaking at the moment t_0 is given as well.

An estimated duration of already executed preparatory actions cpg_1, cpg_3, cpg_4 is reduced to zero in the first step of proposed method on the basis of a report on the enterprise's preparation state for the implementation.

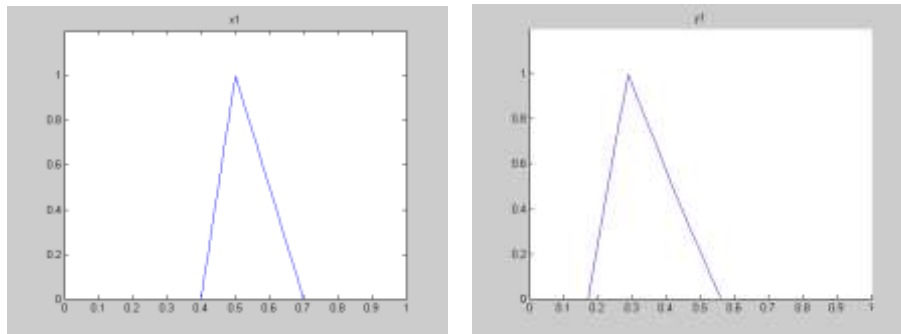

Figure 11. Results of fuzzy reasoning of output value y_1 for fuzzy input value x_1
(source: self study)

A horizontal representation of fuzzy numbers in the form of descending family of closed intervals is utilized in a further procedure. It means that fuzzy durations $T_i = [T_{i_min}, T_{i_mL}, T_{i_mP}, T_{i_max}]$ of individual actions are presented in the form of so called α -sections T_i^α according to the formula:

$$T_i^\alpha = [T_{iL}^\alpha, T_{iP}^\alpha] = [\alpha(T_{i_mL} - T_{i_min}) + T_{i_min}, \alpha(T_{i_max} - T_{i_mP}) + T_{i_mP}] \quad (8)$$

An exemplary form of horizontal representation of fuzzy durations of actions cwe_2 , cwe_3 , and cpg_5 is shown in Table 19.

It can be noticed that for example for the section $\alpha = 0$ the duration of action cwe_2 is [12; 16] days, action cwe_3 [14; 20] days, and action cpg_5 [44; 60] days. Because the action cpg_5 follows the action cwe_3 then the duration of both these actions cannot last shorter than

14 + 44 = 58 days and it cannot last longer than 20 + 60 = 80 days, therefore it is [58; 80] days. Comparing the duration of these two actions the duration of action cwe_2 , executed simultaneously with them, amounting to [12; 16] days, it can be noticed that these actions cannot last shorter than maximum $\{58, 12\} = 58$ days and they cannot last longer than maximum $\{80, 16\} = 80$ days. The time needed to execute the mentioned actions in the form of trapezoidal fuzzy number equal to [58; 64; 68; 80] whose horizontal representation is shown in Table 20, is achieved as a result of continuation of such reasoning for every α -section.

The fuzzy duration of planned undertaking equal to [124; 138; 165; 188] days, presented in Figure 12 is achieved performing a presented procedure for all actions of the analysed implementation.

Table 19. Division into α -sections of fuzzy durations of actions cwe_2 , cwe_3 , and cpg_5
(source: self study)

α	Tcwe ₂ =[12,14,15,16]		Tcwe ₃ =[14,16,18,20]		Tcpg ₅ =[44,48,50,60]	
	Tcwe _{2L}	Tcwe _{2P}	Tcwe _{3L}	Tcwe _{3P}	Tcpg _{5L}	Tcpg _{5P}
1	14	15	16	18	48	50
0,9	13,8	15,1	15,8	18,2	47,6	51
0,8	13,6	15,2	15,6	18,4	47,2	52
0,7	13,4	15,3	15,4	18,6	46,8	53
0,6	13,2	15,4	15,2	18,8	46,4	54
0,5	13	15,5	15	19	46	55
0,4	12,8	15,6	14,8	19,2	45,6	56
0,3	12,6	15,7	14,6	19,4	45,2	57
0,2	12,4	15,8	14,4	19,6	44,8	58
0,1	12,2	15,9	14,2	19,8	44,4	59
0	12	16	14	20	44	60

Table 20. Horizontal representation of fuzzy numbers
[58, 64, 68 and 80]
(source: self study)

α	[58, 64, 68, 80]	
1	64	68
0,9	63,4	69,2
0,8	62,8	70,4
0,7	62,2	71,6
0,6	61,6	72,8
0,5	61	74
0,4	60,4	75,2
0,3	59,8	76,4
0,2	59,2	77,6
0,1	58,6	78,8
0	58	80

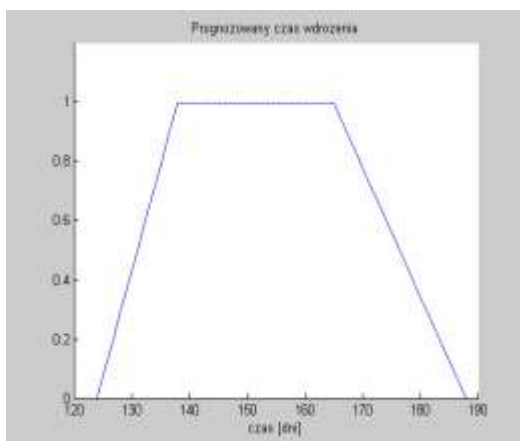

Figure 12. Fuzzy time of implementation
(source: self study)

Stage 2.2 The forecast of DSS implementation cost

The determination of DSS implementation costs is a result of this stage. A way of procedure is discussed on the basis of an example presented below.

The costs of implementation undertaking of given DSS include the costs of purchase, implementation and maintenance. The purchase costs in the case under consideration include a licence costs and costs of server purchase. The implementation costs concern the costs of DSS service and they cover the costs of project management works including among other things a schedule preparation and acceptance of particular stages, costs of trainings, costs of works without participation of the customer and costs of implementation works at the seat of the customer. The maintenance costs include the system service costs which the customer bears since the contract conclusion and the costs of training of new employees. Therefore, the types of costs, connected

with a planned implementation of the system under consideration, listed in Table 1 of this article, are given. The licence cost of specified system $KLC = 300$ of monetary units (corresponding with a determined number of users) is given and the rates of fixed costs (in the form of trapezoidal fuzzy numbers) expressed as % of licence costs, the reference rates, constituting a base of estimation of variable costs with the values of individual reference rates, and also the rates of unit variable costs expressed as % of fixed costs (when there are no fixed costs as % of licence costs) (Table 1) are determined for every type of cost.

In the first place, the values of fixed costs (% of licence costs) and variables (product of unit variable cost value and reference rate value) are determined on the basis of the data for every type of cost RK, then their sum, to which the licence cost is added, is determined. The total cost of planned implementation, achieved in this way, is presented in Figure 13, and it amounts to [385,8; 403,56; 448,88; 468,3] of monetary units (m.u.).

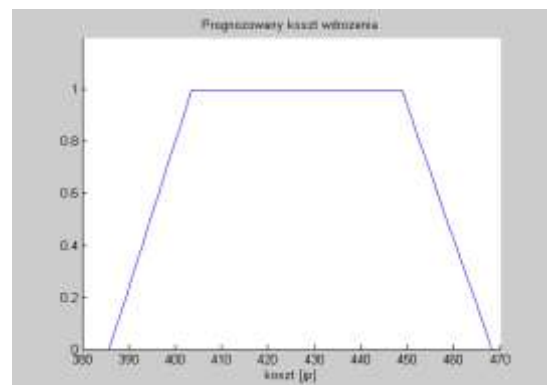

Figure 13. Fuzzy cost of implementation
(source: self study)

Stage 3

The multi-criteria assessment of DSS implementation effects – The determination of values of multi-criteria assessment of DSS implementation effectiveness in relation to target criteria preferred by the enterprise is a result of this stage.

The time determined at the earlier stages (corrected by a specified time of system exploitation) and the cost of planned undertaking and the forecast values of indexes of the enterprise from a planned implementation of DSS are subject to the assessment in relation to the required expectations of the enterprise. A partial assessment of every rate according to an appropriate target criterion is executed in the first step. A value of global assessment for all target criteria is determined in the second step.

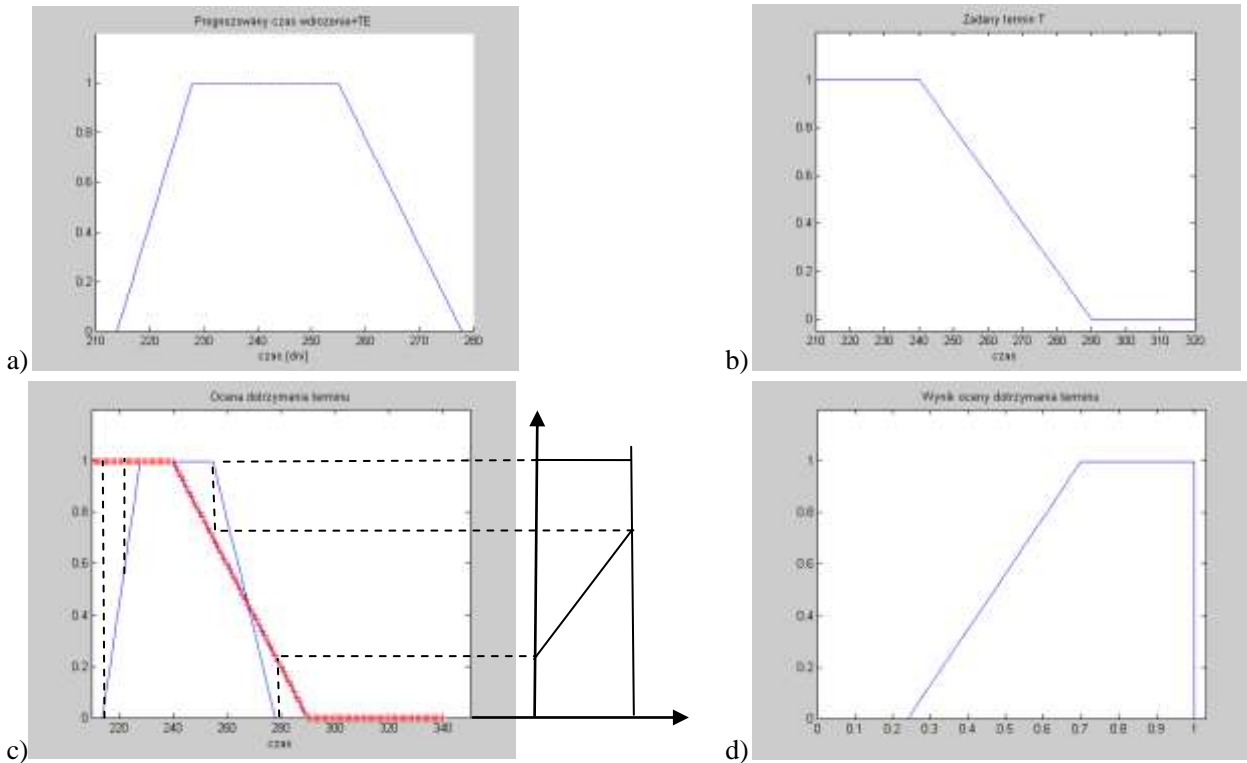

Figure 14. a) Undertaking time, b) Target criterion for undertaking time, c) Assessment of time (a) in relation to criterion (b), d) Result of assessment from (c)
(source: self study)

Stage 3 – Step 1 The partial assessment according to an appropriate target criterion

The values of partial assessments for every target criterion are a result of this stage. A way of partial assessment determination on the basis of an example of selected target criterion which it is adherence of specified time limit is presented below.

The forecast implementation time, achieved at the stage 2.1, determined imprecisely in the form of trapezoidal fuzzy number, equal to [124, 138, 165, 188] days (Figure 12) is given. The assumed system exploitation time equal to $TE = 90$ days is given as well. The time limit T of achievement of preferred values of indexes, specified by the enterprise, is determined imprecisely and it amounts to 240 days (maximum 290 days) (Figure 14b). An answer to a question whether a specified time limit shall be adhered to is retrieved.

Taking into consideration the assumed time of system exploitation $TE = 90$ days, the time needed for the implementation and achievement of preferred indexes is [214, 228, 255, 278] days (Figure 14a). The specified time limit T is 240 days (maximum 290 days) (Figure 14b). The assessment in relation to the specified time limit is presented in Figure 14c in which it is shown

that the time needed for the implementation in the form of trapezoidal fuzzy number is assessed in relation to the affinity function for the specified time limit T , assuming:

- the value equal to 1 when the implementation time is shorter or equal to 240 days,
- the value equal to 0 when the implementation time is equal or longer than 290 days,
- the values of linear function crossing the points (240, 1) and (290, 0), when the implementation time is longer than 240 days but shorter than 290 days.

Therefore the assessment which determines to what degree the adherence of specified time limit T is possible is executed for every α -level. The assessment value achieved in this way is a fuzzy number shown in Figure 14d.

It can be noticed that with the most possible time of the whole undertaking which is equal to 228-255 days ($\alpha = 1$), the adherence of the time limit of 240 days with its certain infringement is possible. In case when the implementation lasts shorter than 240 days, then the time limit shall be adhered, i.e. a degree of time limit adherence is equal to 1, and when the implementation lasts longer than 240 days but it does not exceed 255 days,

then the time limit of 240 days shall not be adhered, however, it shall be acceptable because it shall be shorter than 290 days. The assessment value of 255 days in relation to the specified time limit T is equal to 0,7. Therefore the most possible degree of adherence of time limit T on a scale of [0,1] is 0,7-1 in this case.

Because the longest possible time of undertaking, i.e. 278 days, exceeds the preferred time, i.e. 240 days but it does not exceed a possible time limit of 290 days maximally, the least possible degree of time limit adherence is equal to 0,24.

The exemplary values of implementation time assessment in relation to the specified time limit in case of the afore-mentioned data for various α -sections are listed in Table 21.

Table 21. Implementation time assessment in relation to specified time limit for exemplary α -sections (source: self study)

α	Implementation time t		Degree of adherence of time limit T	
	t_L	t_P		
1	228	255	1	0,7
0,9	226,6	257,3	1	0,654
0,8	225,2	259,6	1	0,608
0,7	223,8	261,9	1	0,562
0,6	222,4	264,2	1	0,516
0,5	221	266,5	1	0,47
0,4	219,6	268,8	1	0,424
0,3	218,2	271,1	1	0,378
0,2	216,8	273,4	1	0,332
0,1	215,4	275,7	1	0,286
0	214	278	1	0,24

Stage 3 – Step 2 The global assessment according to the specified target criteria

Having determined values of individual partial criteria uWE_i , achieved in the step 1, and their weights Q_{uWE_i} established according to the enterprise's preferences, an aggregation of partial assessments is executed, determining a value of target global assessment of planned undertaking. An additive and multiplicative criterion is utilized for the purposes of the aggregation (see [1], [2], [5] and [6]):

- additive criterion:

$$DA = \sum_{i=1}^k Q_{uWE_i} uWE_i,$$

- multiplicative criterion:

$$DM = \prod_{i=1}^k uWE_i^{Q_{uWE_i}}.$$

The use of two criteria during the aggregation of partial assessments gives a possibility of achievement of wider information on a gained final assessment. Because of the fact that the weights correspond with the preferences of given enterprise, they are identical with regard to both criteria.

For example, three fuzzy partial assessments are considered:

- time limit adherence (see Figure14d) – uWE_1 ,
- budget adherence (see Figure15b) – uWE_2 – assessment of forecast implementation cost [385,8; 403,56; 448,88; 468,3] in relation to the specified budget up to 440 (maximum 500) of monetary units shown in Figure 15a,
- achievement of preferred value of index W_1 (see Figure 16b) whose forecast is determined according to the describe of the stage 1 – uWE_3 - assessment of forecast value of index W_1 in relation to the value below 0,1 (maximum 0,6) preferred by the enterprise (see Figure 16, Table 22).

The aggregation of these assessments according to the additive and multiplicative criterion using α -sections whose results are presented in Table 23 and in Figure 17 is executed. Additionally, it is assumed that the criterion of assessment of index W_1 (weight: $Q_{uWE_3} = 0,5$), is the most preferred, and the criteria of time and cost assessment are preferred equally (weights: $Q_{uWE_1} = Q_{uWE_2} = 0,25$). The assessment is contained within a range of [0, 1].

From the achieved assessment it results that according to the additive criterion, the most possible degree of the realization of the targets assumed by the enterprise amounts to 0,70 - 0,81; the least possible degree amounts to 0,23 and the highest possible degree amounts to 0,93. However, according to multiplicative criterion, the most possible degree amounts to 0,69-0,79, the least possible degree amounts to 0,16 and the highest possible degree amounts to 0,93. Therefore there is a possibility that a planned undertaking allows the enterprise to achieve assumed targets event to the degree of 0,93, however, their achievement only to the degree of 0,16 is possible as well. So as it can be seen, a preparation state of enterprise for the implementation and exploitation of specified DSS allows a given enterprise to achieve a preferred value of index W_1 along with the adherence of acceptable time limit and budget.

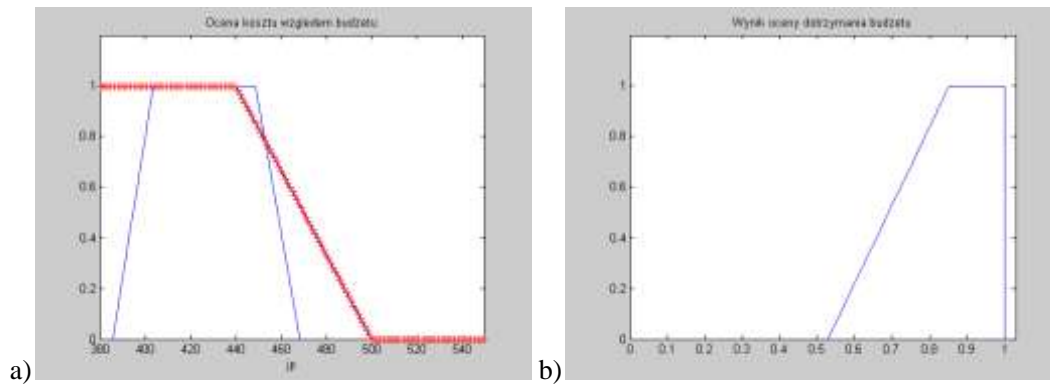

Figure 15. a) Assessment of cost in relation to limited budget, b) Result of assessment from (a)
(source: self study)

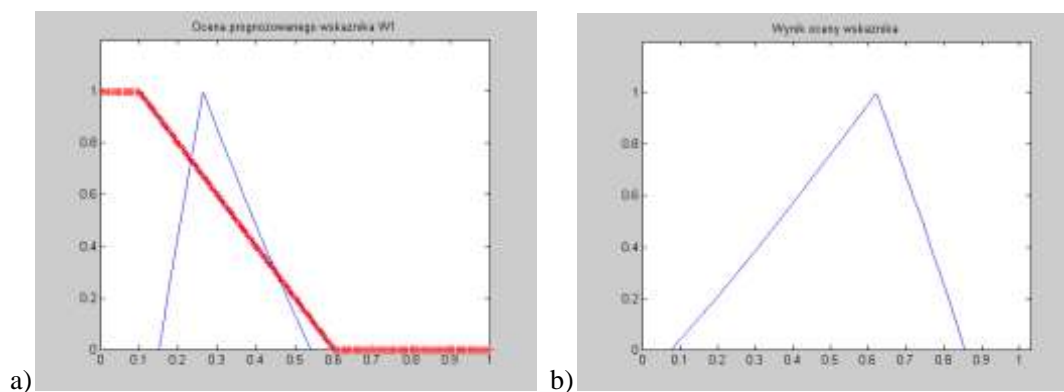

Figure 16. a) Assessment of forecast index W_1 in relation to preferred value WE_1 , b) Result of assessment from (a)
(source: self study)

Table 22. Assessment of forecast index W_1 in relation to preferred value WE_1 for exemplary α -sections
(source: self study)

α	Forecast of index W_1		Degree of achievement of preferred value	
	1	0,2897	0,2897	0,6206
0,9	0,2772	0,315	0,6456	0,57
0,8	0,2648	0,3406	0,6703	0,5188
0,7	0,2526	0,3665	0,6948	0,4669
0,6	0,2405	0,3927	0,719	0,4145
0,5	0,2286	0,4193	0,7428	0,3614
0,4	0,2168	0,4463	0,7664	0,3074
0,3	0,2052	0,4739	0,7896	0,2521
0,2	0,1938	0,5023	0,8124	0,1953
0,1	0,1826	0,5316	0,8348	0,1367
0	0,1716	0,5619	0,8567	0,0763

Table 23. Global additive DA and multiplicative DM assessment using exemplary α -sections
(source: self study)

α	Time limit adherence		Budget adherence		Achievement of index		DA		DM	
1	0,70	1	0,85	1	0,62	0,62	0,70	0,81	0,69	0,79
0,9	0,65	1	0,82	1	0,57	0,65	0,65	0,82	0,65	0,80
0,8	0,61	1	0,79	1	0,52	0,67	0,61	0,84	0,60	0,82
0,7	0,56	1	0,75	1	0,47	0,69	0,56	0,85	0,55	0,83
0,6	0,52	1	0,72	1	0,41	0,72	0,52	0,86	0,50	0,85
0,5	0,47	1	0,69	1	0,36	0,74	0,47	0,87	0,45	0,86
0,4	0,42	1	0,66	1	0,31	0,77	0,42	0,88	0,40	0,88
0,3	0,38	1	0,63	1	0,25	0,79	0,38	0,89	0,35	0,89
0,2	0,33	1	0,59	1	0,20	0,81	0,33	0,91	0,29	0,90
0,1	0,29	1	0,56	1	0,14	0,83	0,28	0,92	0,23	0,91
0	0,24	1	0,53	1	0,08	0,86	0,23	0,93	0,16	0,93

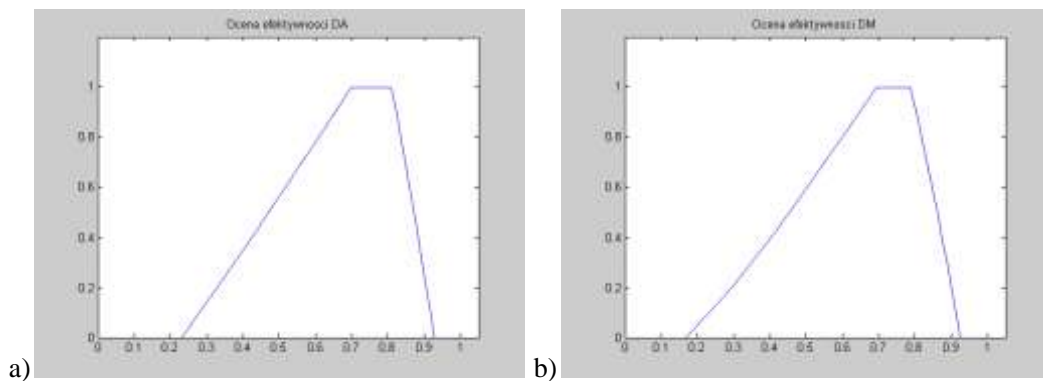

Figure 17. a) Result of global additive assessment b) Result of global multiplicative assessment
(source: self study)

4 The computer-aided support of multi-criteria assessment of DSS implementation effectiveness

The computer-aided support of multi-criteria assessment of DSS implementation effectiveness, in which appropriate modules – with which buttons shown in Figure 18 correspond – are assigned to individual stages of the method, is an implementation of multi-criteria assessment method of DSS implementation effectiveness. The system allows to execute an effectiveness assessment of planned implementation of specified DSS in a selected enterprise in relation to its requirements. It is assumed that these requirements are determined by means of values of indexes, preferred by the enterprise, describing the effects of given implementation which it would like to achieve in a specified time limit and without going over a limited budget.

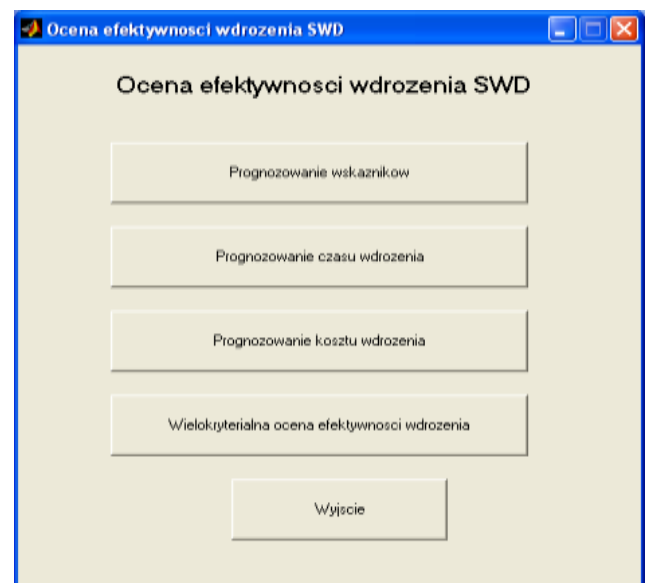

Figure 18. Main window of assessment system of DSS implementation effectiveness
(source: self study)

The system is built of two layers. The first layer is constituted by a computable part, being a computer-aided implementation of the method describing in the point 3 of the article, however, the second layer is formed by a graphic interface supporting the user in the introduction of the data, realization of individual stages of proposed method and graphic interpretation of achieved results. The system is implemented in the MATLAB environment.

The operation of the system boils down to the determination of:

- forecast values of selected indexes of the enterprise from a planned implementation, using a knowledge base which is created on the basis of earlier gained experiences, by means of module: Prognozowanie wskaźników (eng. Forecast of indexes),
- duration of planned implementation undertaking, taking into consideration the enterprise' preparation state, by means of module: Prognozowanie czasu wdrożenia (eng. Forecast of implementation time),
- costs of planned undertaking, by means of module: Prognozowanie kosztu wdrożenia (eng. Forecast of implementation cost),
- multi-criteria assessment of target effectiveness of planned undertaking in relation to subjective criteria preferred by the enterprise (preferred time, cost and values of indexes), by means of module: Wielokryterialna ocena efektywnego wdrożenia (eng. Multi-criteria assessment of implementation effectiveness).

5 Summary

The presented multi-criteria assessment method of DSS implementation effectiveness enables to forecast the effects of planned DSS implementation and their assessment in relation to the implementation objectives, preferred by a given enterprise. For these purposes it makes use of the knowledge collected on the basis of earlier realized implementations and imprecise description of parameters in order to take the uncertainty connected with the future into consideration. A system serving to support a DSS implementation process in the enterprises is a computer-aided implementation of the method.

6 References

- [1] Dymowa L., Figat P., Zenkova A. - *Metoda i oprogramowanie do oceny wielokryterialnej i wielopoziomowej decyzji w warunkach niepewności rozmytej* [at] III Krajowa Konferencja nt. Metody i systemy komputerowe w badaniach naukowych i projektowaniu inżynierskim. Kraków, 19-21 November 2001, pp. 575-576.
- [2] Figat P. - *Opracowanie metody i oprogramowania do wielokryterialnej i wielopoziomowej oceny alternatyw w zagadnieniach podejmowania decyzji*. Praca magisterska, Politechnika Częstochowska, Częstochowa 2002.
- [3] Piegat A. - *Modelowanie i sterowanie rozmyte*. Akademicka Oficyna EXIT, Warszawa 1999.
- [4] Piegat A. - *Fuzzy Modelling and Control*. Springer-Verlag, Berlin/Heidelberg 2001.
- [5] Róg P. - *Opracowanie metodyki i oprogramowania do operowania na danych przedziałowych i fuzji w zastosowaniach modelowania procesów produkcyjnych i podejmowania decyzji*. Praca magisterska, Politechnika Częstochowska, Częstochowa 2002,
- [6] Róg P. - *The method of Intervals Ordering Based on the Probabilistic Approach* [in] Computer Science, Vol 1, No. 1, 2000, pp. 103-108.
- [7] Ważna L. - *Application of fuzzy modelling and inference to building the tool of support of the effects evaluation of ERP APS system implementation in enterprise* [in] Management, Vol. 12, No. 1, 2008, pp. 202-212.
- [8] Ważna L. - *Ocena wdrożenia zintegrowanego rozwiązania informatycznego wspomagającego zarządzanie wiedzą w średnim przedsiębiorstwie produkcyjnym* [in] Zeszyty Naukowe Uniwersytetu Szczecińskiego. Ekonomiczne Problemy Usług, No. 544 (No. 35), 2009.
- [9] Ważna L. - *Wykorzystanie modelowania rozmytego do oceny efektywności celowej planowanego wdrożenia ERP APS* [in] Modele inżynierii teleinformatyki: wybrane zastosowania (ed. M. Kopczewski). Wyd. Ucz. Politechniki Koszalińskiej, Vol. 3, Koszalin 2008, pp. 282-287.

BUSINESS CONTINUITY

Janusz ZAWIŁA-NIEDŹWIECKI

Faculty of Management

Warsaw University of Technology, 02-524 Warszawa, Poland

email: jzawila@poczta.onet.pl

Abstract: Improving organization means on the one hand searching for adequate product (service) matched to the market, on the other hand shaping the ability to react on risks caused by that activity. The second should consist of identifying and estimating types of risk, and consequently creating solutions securing from possible forms of its realization (disturbances), following rules of rational choice of security measures as seen in their relation to costs and effectiveness. As to types of risks from which the organization is not secure, the procedure left is to create plans for securing continuity of operations which ensure return to previous state in due course and ensuring replacement operations for the transitory period. Activities of creating the security measures and continuity solutions should be organized as constantly developing and perfecting and as such they need formal place in organizational structure and rules of management.

Key words: operational risk management, business continuity management.

1 Introduction

Ensuring business continuity encompasses:

- mechanism of reaction for disruptions of an organization (partly based on homeostasis, that is, spontaneous reaction of organization elements, and on systematically developed and studied ability to react), which consists in formation of the organizational skill of reacting to disruptions,
- process of development of the above mentioned ability to react to disruptions (as a supporting process for core organization activity, from the point of view of process analysis),
- process of managing the current ability of ensuring business continuity and its constant development.

Disruption reaction mechanism consists of:

- organizational structure dedicated to ensuring business continuity being an integral part of the general organizational structure,
- formal organizational regulation determining relations in the organizational structure connected to the task of ensuring business continuity,
- established practice (possibly written) of actions in situations when reaction to disruption, which has appeared, is required.

It is particularly important to underline, that reaction to disruption viewed as ensuring business continuity should be understood not only as direct action in the face of disruption, but also as preventive activity con-

nected with analysis of threats and weaknesses and search for solutions and methods of averting the occurrence of threats. In this sense, the efforts towards business continuity and safety interlace with one another. From the point of view of business continuity, the safety solutions ensure prevention against threats, while from the point of view of safety, the business continuity solutions constitute a good insurance, in case other safety means fail to work properly (see Figure 1). This supports the concept of managing both issues jointly, and also together with quality, which is directly recommended by ISO 9000, 14000, 27000 and planned 31000 series.

Therefore, whenever speaking of:

- “business continuity” – it is spoken of postulated state of immunity of organization against disruption,
- “ensuring business continuity” – it is spoken of series of planned events, which aim at preventing disruption or removing causes and effects of disruptions, or introducing alternative conditions for activity until the effects of disruption are removed,
- “managing business continuity” – it is spoken of a management process, which consists in defining tasks, planning and monitoring the elaboration of solutions for ensuring continuity, evaluating actions and drawing conclusions from potential and existing disruptions, which aim at ensuring business continuity.

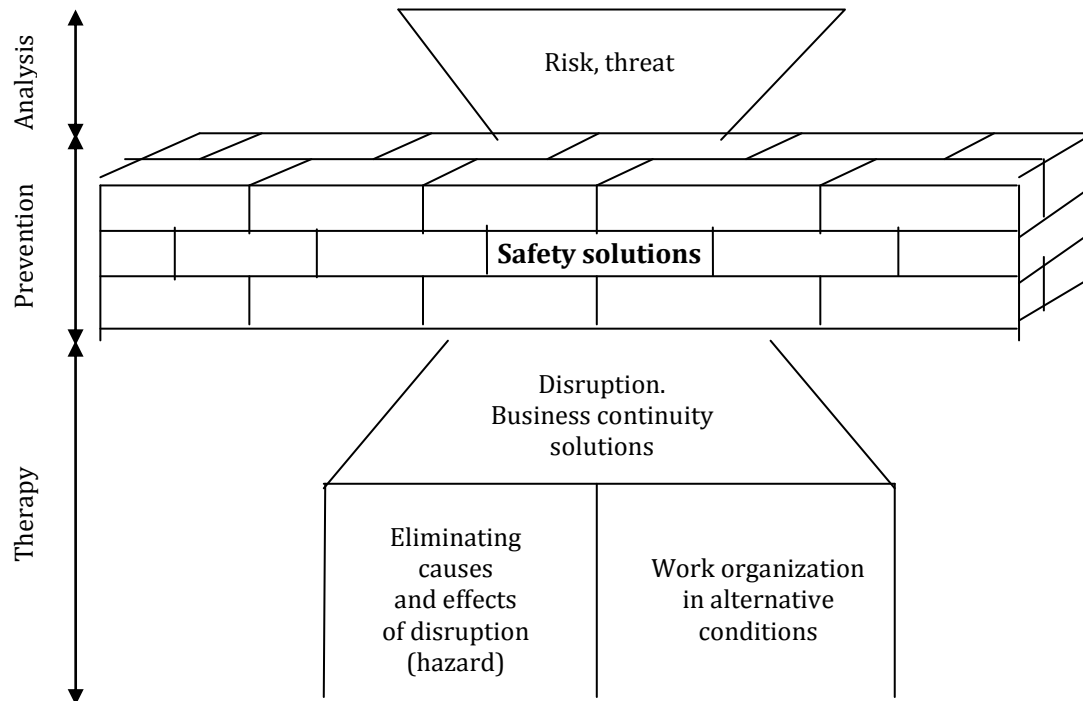

Figure 1. Relations between safety and business continuity ensuring tasks
(source: self study)

Organizational activity which aims at ensuring business continuity refers to the following issues, that should be taken into account or ensured:

- when a given threat influences the business system or its direct surrounding and the system becomes susceptible to this influence, we are dealing with a disruption, which:
 - is a result of an interaction between threat and business system or business system's surrounding,
 - results with considerable changes in the area of system functioning,
 - cannot be subject to objective evaluation, while subjective evaluation is made from the point of view of business system,
- possibility of occurrence of disruptions, which will obstruct normal continuation of the organization activity,
- independently from the character of reasons of these occurrences, as part of a formal or perceived in business categories responsibility to do one's best to execute their tasks, an organization should aim at least at limited continuation of business,
- this effort should be based on pre-elaborated, consistently perfected and tested plan for business continuity, sometimes also called (though in a slightly narrower sense) the emergency plan,
- ensuring business continuity means foreseeing scenarios of potential disruptions and separate design of:
 - solutions preventing the threats themselves (mainly ensuring safety),
 - solutions for quickest possible removal of effects of disruptions,
 - solutions for continuation of limited activity in critical conditions,
- attitude towards the problem of business continuity ought to be rational, that is, targeted at obtaining balance between expected level of certainty of maintaining business continuity and costs of reaching it; it is, therefore, necessary to adopt the assumption of gradual giving up of specific elements of normal business, adequately to the identified magnitude of the critical situation (persistent effort towards maintaining business continuity does not always have sense, especially from the point of view of economics),
- continuity plan should be elastic enough to enable adaptive reaction to disruptions which differ from the expectations, which were the base for the plan,
- it is necessary to define the core process of a given organization as a minimum set of actions, which still allows to conclude that the organization serves its purpose; inability to carry out such a minimum

set of actions is the basis for the decision concerning abandoning the use of continuity plan and concentration on removal of disruption effects only,

- when elaborating a continuity plan, business, legal and organizational issues are considered in the first place, as they determine the necessary scope of technical solutions,
- business analysis may cover the issue of company prestige and, surely, balancing risk as well as financial means devoted to its risk limitation; it is wise to treat the continuity plan as a long-term project, in which the marked out goals are achieved gradually, by means of consequent approximations (versions of business continuity plan),
- legal analysis is especially important when creating assumptions of continuity plan, because it enables to define the scope of company responsibility for particular fields of its activity, point out trouble spots and choose appropriate non-technical safety measures,
- organizational analysis enables to distinguish members of staff appropriate for using the continuity plan in critical conditions, to create an adequate level of decision autonomy in this situation and, in everyday conditions, enables to preparation for such a difficult role,
- none of the analysis elements, nor the design of technical solutions, is a self-contained stage; improving the continuity plan consists in constant repetition of analyses and design of solutions, which refer to changes in organization activity, development of continuity plan and conclusions from real disruptions.

In accordance with the ISO 27002 standard, when managing organization activity one should design solutions which effectively ensure maintaining business continuity of the organization. Analogically to living organisms, these solutions are to determine the ability of homeosthesis, that is, the characteristic of an organization which consists in launching own, inner mechanism of counteracting disruption in order to restore the situation from before this disruption. Effectiveness of disruption-anticipating solutions and their adequacy with reference to real occurrences should place itself above the minimal acceptance level of decision-makers. The decision-makers' evaluation is usually based on two criteria:

- organization prestige and the degree of its impairment in case of limiting or suspending activity,
- relation of costs of safety solutions to costs of po-

tential losses and costs of resuming action that was disrupted.

Rationally viewed homeosthesis of a business system leads to conscious, temporary limitation of business quality, to the level pre-determined in the light of such determinants as:

- loss of an unsatisfied or harmed client,
- benchmarking with respect to competitors or best market practices (benchmarking is a systematic and continuous process of measurement; goal of the process of constant measurements and comparisons of organizational activity to leaders in economic processes worldwide, is to gather information, that will help the organization to undertake actions which will improve its functioning"; definition of American Productivity and Quality Center, B. Andersen, *Benchmarking*, 1992),
- reliable standards for cooperation with clients and partners, so called "service level agreement" (realistic and precise definition of parameters of provided services by the involved parties, including acceptable levels of unavailability of those services, as not violating the terms of a contract, i.e. servicing contract. See also: Hiles A. „Service Level Agreements: Measuring Cost and Quality in Service Relationships", Chapman & Hall, London, 1993).

Systematic approach to disruptions consist in determining:

- which disruptions (threats in interaction with business system) are being counteracted, that is, are covered by procedures for prevention or procedures for ensuring continuity,
- which technical infrastructure objects are protected against possible threats,
- which business processes are protected against threats,
- which information flows are being protected against threats,
- who is responsible for restoring business continuity in case of occurrence of disruption.

Limiting the quality of functions should not last longer than the amount of time needed to remove causes and effects of disruption, whereas the former can disappear by themselves if such is the nature of the disruption.

2 Organization of management

Ensuring business continuity, being an indissoluble organizational activity, needs to be permanently fixed into the organizational structure and formal documentation, which describes the structure, its rights and obligations (regulations, scope of obligations, procedures of activity). The term “permanent organizational activity” refers to the fact that business continuity tasks concern all the employees and all the organizational units and their managers, together with the current tasks, execution of which could be disrupted. In case of some professions it can also be pointed out, that ensuring continuity lays in their immanent nature (i.e. profession of engineer) both in the aspect of content matter (i.e. in design, the unreliability of technical solutions should be assumed) and ethics.

Subsequently, from the organizational point of view, it is necessary to distinguish between current efforts towards maintaining business continuity in the face of minor difficulties in task realization (at all posts and in all situations) and planning of reaction of bigger organizational parts or the whole organization to events, which are extensive accidents (catastrophes). The former one, in the model organization management, is written down in the organizational regulations, in the area of rights and obligations scope of organizational units, employees and management. Obviously, both categories should be, furthermore, divided into preventive actions towards probable disruptions and repair actions in case of occurrence of disruption (see Table 1).

Table 1. Classification of business continuity ensuring actions
(source: *self study*)

	Current	Emergency
Prevention	Technical checks Material inventories Servicing attendants	Emergency plans and resources
Reaction	Help-desk Servicing	Alternative work organization in emergency conditions

The latter one, that is preparation for extensive accidents, requires special organizational solutions. Their main prerequisite is the character of events, for the occurrence of which one has to prepare, and, in particular, their possible extensiveness and possible far-going dissimilarity to the experience of current operations.

This prerequisite justifies specific solutions, however, it is important to remember that the issues of ensuring business continuity are strictly related to ensuring safety in different aspects. The organizational solutions should, therefore, be created together and work simultaneously for the benefit of solving the both general problems.

These solutions may be divided into categories from the fields of:

- forming of the organizational structure,
- formal regulation of code of conduct,
- direct solutions for ensuring business continuity.

In the field of forming of organizational structure, the tasks of ensuring business continuity should be a part of a general concept of operational risk management. To high extent this depends on the given entity’s specific character, including its size, because the smaller the entity, the more direct its management’s involvement in solving each particular problem, managing risk, safety and business continuity is. The other way round, as we describe hereafter, looks the model solution concerning large companies, corporations in particular, where the highest management levels are in fact detached from operational practices and require support in the face of extraordinary events (including malfunctions), but also with regard to operational risk management.

Figure 2. depicts such a model example based on international recommendations of so called Basel Committee (full name is the Basel Committee on Banking Supervision, an international consulting body acting in the character of “wise men council”, which operates in the banking sector next to the Bank for International Settlements in Basel, where the committee takes its popular name from, created for the purpose of establishing common recommendations of good practices. The result of the Committee’s work is an extensive group of recommendations well known under the names of Basel I and Basel II. See www.bis.org/bcbs).

The highest management (boards) of these entities deals in practice almost exclusively with strategic matters, especially in the sense of long-run decisions, and from among the current problems only with large-scale ones. Current affairs management is handed over to a new level of high management (managing directors), created solely for this purpose, based on the new type of organizational structure orientated towards market-segments, client target groups, product and related processes.

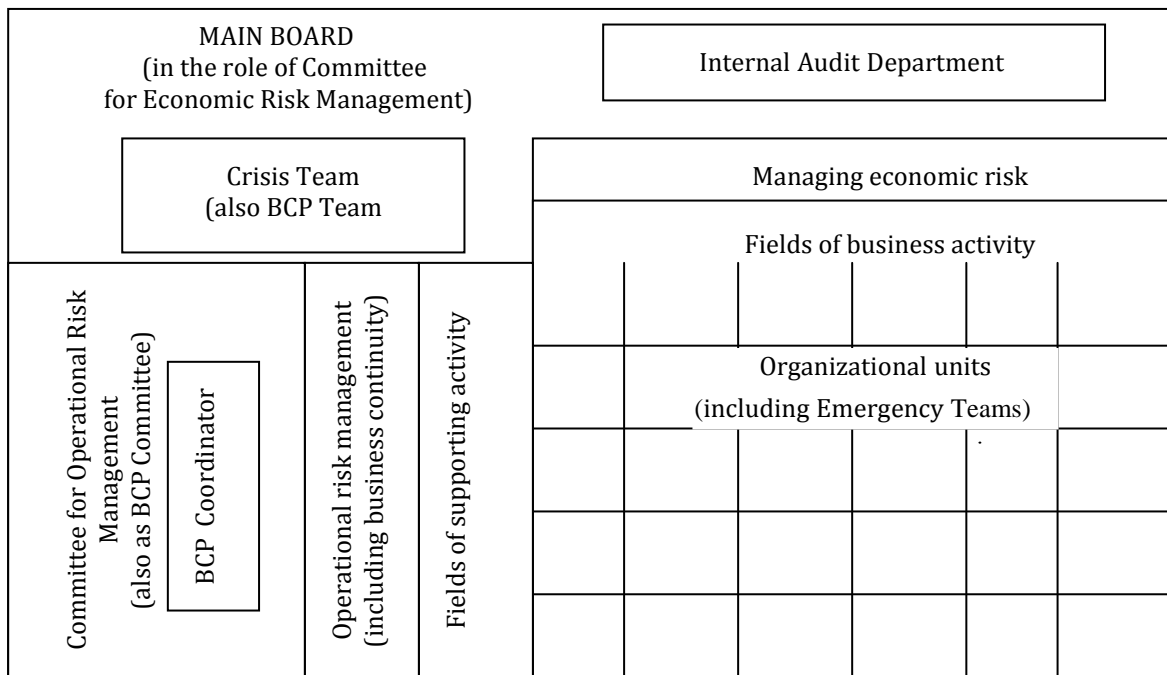

Figure 2. Model of risk, safety and business continuity management organizational structure, according to recommendations of the Basel Committee
(source: self study)

In banks, for example, separately managed departments of retail, institutional and investment etc. banking are established in accordance with the process approach. These departments become strongly autonomous parts of organization with their own strategy, plans and budgets as well as independent plan of supporting resources, which constitute material, technical and organizational basis for operating conditions, that is, realization of business plans. This basis consists of i.e.: workstations' equipment, ensuring staff with proper qualifications, IT services etc.

Taking into consideration the size of business and, simultaneously, the expectation of high effectiveness, not only organizational (quality, punctuality, productivity), but also cost-related, the particular parts of supporting activity require perfect organization and even greater effectiveness and, subsequently, resistance to disruptions, than core business activity. As a result, it is necessary to see the need for clear detachment of economic (business) risk management, such as: market, financial or legal risk etc, from operational risks (of internal organization).

From the above mentioned prerequisites results a concept of two decision centers which, in the documentation of Basel Committee, are referred to as Councils.

One of them is business-tasks-oriented and devoted to managing economic risk, while the second one is supporting-actions oriented and manages operational risk (risk concerning appropriate organizational effectiveness in the field of realization of business activity supporting processes).

Let us notice that the Council/Committee for Operational Risk Management, recommended by the Basel Committee, is a task-orientated body, which proceeds periodically, possibly even regularly and often. After all, this situation is not very different qualitatively from the way the Board acts (as a kind of Council/Committee for Economic Risk). On a day to day basis the Board Members function in individual roles, determined and accounted for separately, and form the actual board only *en bloc* in situations described by the Commercial Companies Code and charter of the organization. Acting as a Board they make use of a certain office, team and control apparatus (i.e. board services office, team of advisors, internal audit department), directly subordinate to it. The case of Operational Risk Committee should look analogically.

At the same time, the current office work apparatus of the Operational Risk Committee can be dedicated to the matter of ensuring business continuity or analyzing

and preventing operational threats. In this work it was called BCP Coordinator. With regard to the fact that operational threats may materialize, there is a need to establish another task-oriented body such as Crisis Team (BCP team) apart from the existing permanent organizational structure. This team, in the time of peace and order, should systematically prepare itself and the whole organization for planned mobilization in case of critical disruption, malfunction and catastrophe.

With regard to ensuring business continuity, the fundamental roles depicted in Figure 2. are as follows:

- BCP Committee (alternately as a part of Committee for Operational Safety) – task-oriented body which gathers periodically it should have high level of authority coming from the Board (best solution is that it contains one Board Member); it is to delegate (and account for the execution) specific tasks to the individual organization units, as a part of gradual preparation of BCP documentation and solutions and acquiring skill of acting in crisis situations,
- BCP Team (or Crisis Team) – team of specialists, equipped with appropriate authorization of the Board and adequate means, prepared for directing crisis recovery process, should a crisis occur,
- BCP Coordinator – person or team of people who should possess the authorization of the BCP Committee (Operational Safety), in order to coordinate the realization of tasks set by the Committee for individual organization units in the periods between the Committee meetings; it is also responsible for running and distributing up-to-date BCP documentation (plans, scenarios), organizing trainings and

tests; in case of a crisis it supports the BCP Team’s actions,

- Emergency Teams - task-oriented bodies needed by individual local units, subordinate to the BCP Committee, acting locally in the same manner in which the BCP Team operates centrally; if needed, in case of a crisis, also in the main office (headquarters), task-oriented bodies in the most important cells, such as administration or IT departments.

3 Rules of Management

Problem of ensuring business continuity should be viewed in four categories of situations, which might occur in the light of basic risk factors, which are: probability of realization of a given critical incident and the size of potential result of this incident. This is illustrated in Figure 3.

Tolerance refers to acceptance of temporary inconveniences. Monitoring means that knowledge about the disruption is sufficient for launching of a compensation mechanism. Prevention means actions towards aversion of negative effects of disruption. Business Continuity Plan is a set of scenarios describing expected realization of threats and planned responses to these threats.

Approach of Tolerance should be connected with those disruptions, which in their nature are external to the organization, and secondarily relate to the organization; especially those which are non-invasive and not destructive. For example: Transportation company which distributes press – waits through the morning fog and distributes the newspapers later.

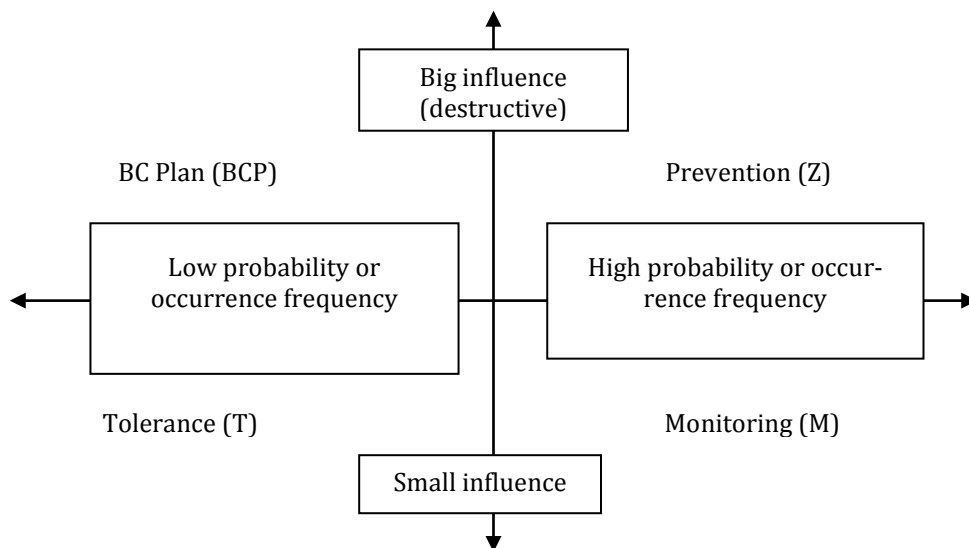

Figure 3. Model approach to disruptions (source: self study)

Monitoring approach should be connected with dealing with those disruptions, which in their nature are small but frequent (therefore, their incidentally bigger influence as a result of accumulation in short period should be assumed), however, clearly not destructive. This strategy should result in a detailed solution through organizational actions and detailed internal regulation of reaction to all typical disruptions. The essence of this strategy is a faint or none rise in costs resulting from reaction solutions, as they have, above all, organizational character. For example: employees' sick leaves – obligation to inform the company beforehand and established rules for organizing replacements.

Prevention approach should relate to substantial, destructive and potentially frequent disruptions. The natural consequences of the prevention strategy are investments and solutions which limit the risk of threat. Typical action is creating back-ups of technical solutions. For example: frequent energy shutdowns – installation of uninterruptible power supply or power generators.

Business Continuity Plan approach should be connected with reacting to substantial, destructive but potentially rare disruptions, which supports the decision about resigning from Prevention approach and conscious acceptance of the related risk of threats. For example: Stock exchange – world statistics say that stock quotations are suspended because of computer system malfunction no more often than once every three years and the suspension does not last longer than one day. It is, therefore, reasonable to rely on an alternate functioning scenario in case of such a rare but serious malfunction.

Policy of Tolerance (T) should specify the basic conditions which must be met for a company to approach to accept the disruption which occurred, research the prerequisites for its duration, affirm its regression and return to the routine functioning. T Policy documentation should encompass procedures/instructions describing in detail the necessary actions of organization cells in case of disruption which qualifies to be subject to this policy. For example: although the organizational reaction for disruption may, at the end, consist in suspending the execution of statutory functions, maybe it is necessary to communicate this fact to trade partners and to the public, reallocate workers to substitute duties which are unaffected by the disruption, launch solutions which track the intensity level of the disruption. In the moment the disruption disappears, it has to

be verified whether it is possible to restore the previously suspended activities/functions.

Policy of Monitoring (M) should specify the basic rules of organizational reaction to disruptions, with regard to which the awareness of their occurrence together with the existing regulations (if need be, written down as procedures and instructions) should, to the sufficient degree, launch the organizational mechanisms of disruption compensation. M Policy documentation should encompass procedures/instructions describing in detail the necessary actions of organization cells in case of disruption which qualifies to be subject to this policy. For example: in a bank, it is obligatory for the direct client service personnel to inform beforehand about the absence caused i.e.: by illness; defined number of back-office personnel members are trained to be able to work as replacements in case of an extraordinary absence, that was not communicated beforehand by a front-office worker.

Policy of Prevention (P) should specify the organization plans concerning preventive actions, which ought to neutralize the destructive influence of disruptions with regard to particularly important elements of organizational activity, especially the sensitive elements of its technical infrastructure. P Policy documentation should contain detailed analyses of the degree and scope of sensitivity of existing solutions, plans of solutions which could decrease the threats, procedures/instructions describing in detail the organization and rules of current operations as well as specialist teams interventions aimed at fighting specific threats (fire, hacker attack, IT malfunction). For example: back-up computer center, multiple means of communication, using different physical paths and transmitting media. Also, keeping special intervention groups with appropriate qualifications on duty.

At the same time, it is important to underline that each object-threat couple contained in policy P, the preventive actions plan, if it consists in threat-decreasing investment, should be, simultaneously, included in one of the other policies until it is finished, in order to ensure proper reaction to threat (it is recommended to include it in BCP policy).

Policy of Business Continuity Plan (BCP) should specify the organization plans concerning actions which are necessary in case of realization of a threat. Plans should encompass organization plans with regard to carrying out the Policy itself and different case scenarios

of disruptions and planned counteractions, aiming at ensuring continuity of at least core business of the organization. Moreover, BCP policy should define the rules of ad hoc reactions to events which, unfortunately, could not be foreseen in the scenarios (at all or with regard to scale). BCP policy documentation should contain procedures/instructions specifying in detail the organization of bodies which carry out the business continuity plans, basic rules of communication in face of emergency, rules of reaction to typical threats, scenarios of expected extensive disruptions and reacting to them, rules for including the experiences from current disruptions in the future versions of emergency plans.

Managing business continuity is such a young area of knowledge, that it is hard to find a commonly used and well practice-based methods of its evaluation. Nevertheless, such proposals have already appeared. The most famous one is the Business Continuity Maturity Model (BCMM), a method established by an American company Virtual Corporation Inc., www.virtual-corp.net, see Table 2.).

Idea of the method is such that a company (an organization) gradually reaches higher levels of maturity by introducing permanent organizational structures, participants' roles, rules and action plans. Simultaneously, it is possible to step back in situations when the organization or its surrounding undergo profound technological or organizational changes. Particular levels are characterized as follows:

- Level 1

The highest management does not think that BCP problems are important or require being centrally governed. BC issues are dealt with by individual organizational cells according to their own level of expertise and to the level they consider right.

- Level 2

Strategic meaning of BCP problems is recognized by some organizational unit. In the organization or among its specialist advisors there is a specialist, who can support BCP works. The highest management views BCP as an important matter, but does not prioritize it properly yet. Level 3 – Organizational cells which are most interested in BCP problems carry out joint activities concerning BCP. However, it is not a BCP for the whole company. The highest management is aware of this initiative and actions, supports them, but is not able to establish proper structures, tasks and Business Continuity Plan.

- Level 4

The highest management is aware of the strategic meaning of BCP. Permanent office which deals with BCP problems is established. Integrated solutions for the company as a whole are being established. Critical processes were identified and protection plans were established. They are being tested and updated on a routine basis.

Table 2. Business Continuity Maturity Evaluation method
(source: Virtual Corporation, Inc.)

Maturity level of continuity management		Program Basics			Program Development		
		Senior-Management Commitment	Professional Support	Governance	All Units Participating	Integrated Planning	Cross-functional
Level 1	Self-Governed	No	No	No	No	No	No
Level 2	Supported Self-Governed	Marginal	Partial	No	No	No	No
Level 3	Centrally Governed	Partial	Yes	Partial	No	No	No
Level 4	Enterprise Awakening	Yes	Yes	Yes	Yes	No	No
Level 5	Planned Growth	Yes	Yes	Yes	Yes	Yes	No
Level 6	Synergistic	Yes	Yes	Yes	Yes	Yes	Yes



 direction of maturity level growth

- Level 5

All organizational cells have tested BCP plans positively, including rules of introducing changes to plans. The highest management has also participated in the tests. Couple-year long BCP solutions development program has been elaborated.

- Level 6

All organizational cells have received high evaluation notes of BCP preparation. Cooperation of cells is tested. All factual changes in business processes as well as potential changes to BCP plans themselves are being followed and adapted to BCP solutions.

4 Designing and maintaining business continuity plans

The basis for implementation of policy of dealing with disruptions is a proper plan containing the following stages.

4.1 Analysis of organizational processes

Modern system approach to management is characterized by the concept of viewing organization as a business system, in which the key element is right and effective management of processes and not the classic functional organizational structure. Traditional views on organization described by the problem of effectiveness of particular functional departments and organizational cells lead to atomization of those organizational units, and the care for own, inner effectiveness, paradoxically, does not increase but decreases the effectiveness of the whole organization. What is more, striving for inner micro-perfection of organizational cells separates them from the environment, including, what is particularly critical, clients, cooperators and competition.

Process approach, on the other hand, leaving the improvement of functioning within the competence of organizational cells, means that management is concentrated on coordination of organizational cells' tasks and relations with the environment, in the light of clearly defined goals: organization, processes and workstations. Achieved in this way are:

- optimization of organizational functioning,
- rationality of organizational cells' cooperation,
- viewing client needs as the highest goal of an organization,
- viewing services as a result of relations with the environment,
- identification of the way work is performed.

Ant the work itself is viewed and organized through a process, that is, series of actions, as a result of which product or service is created. Process is also a chain of adding value. Identification and analysis of processes, as a starting point for decisions with regard to business continuity management, may result in drawing vital conclusions leading to reengineering of processes and work organization.

The result of process analysis is a so called "process map". For a single process, such a map is a sequence of operations, which lead to turning certain resources into effects. Creating a process map starts with identifying all the subjects (organizational cells) which participate in the process and, next, consists in describing which following actions, with the use of what resources, performed by which organizational cells, constitute the process.

Under the current, common use of IT solutions it is necessary to remember, that properly designed IT systems reflect the flow of processes through workstations, which are operated by a given system.

Table 3. Variables of Process effectiveness analysis
(source: [12], p. 61-109)

Organizational level	Organizational goals	Organization design	Organization management
Process level	Process goals	Process design	Process management
Workstation level	Workstation goals	Workstation design	Workstation management

Therefore, system analysis should accompany process analysis in order to:

- identify processes or their elements, if classic process analysis is impeded,
- verify if information/IT system properly and sufficiently operates the analyzed processes,
- identify physical paths of information flow, which supply, accompany (are the elements of) or are the results of a process.

The last point refers to determining places and paths for information flow, which may be threatened by the influence of disruptive factors.

Need for analysis of information and IT systems also results from the specific role of information in management, which, as a factor that increases our knowledge of the surrounding reality, is sometimes called the “blood-system of management”. Information are the basis (input) for process management, describe the course of processes, are one of process inputs and results.

Information flows take place through physical paths (channels): traditional ones, which are defined by process organization or determined by telecommunications infrastructure. Potentially, this leads to physical discrepancy between paths of sharing information in an IT system (in this case, information sharing uses such technical channels of communication as: cable network, wireless network) in relation to traditional information flow consistent with process flow, viewed as relation between the following workstations. This discrepancy is an important factor which increases the critical susceptibility to disruptions.

Possible channels of information flow are:

- traditional, connected with passing paper documents,
- conventional telecommunications (phone calls, faxes),
- electronic telecommunications, providing digital data transmission.

When analyzing information flows, with regard to all the channels, we take into consideration:

- consistence and discreteness of information flow within a given business process,
- degree to which information flow accompanies business process,
- means of sharing information and their susceptibility to disruptions,

- degree to which basic means can be replaced by alternative ones,
- critical elements of information flow.

4.2 Analysis of threats to organization

Analysis of threats is made with the use of a model “list of threats” (see Table 4.). At the beginning the threats which are inadequate to the situation of a given organization have to be crossed out from the table and, possibly, other organization-specific threats need to be added.

Next, it is evaluated if a given threat has got internal or external character from the point of view of the organization. It has to be determined if the threat within the organization realizes itself in its real form and if it constitutes the organization’s problem, i.e.: whether a hurricane is a properly identified threat, or should it rather be the damaged building structure. External threats result in internal ones and, therefore, we aim at determining the latter ones. Consecutive iterations of evaluation (verifications) may be needed in order to cross out the external threats as being unlikely or replacing them with more precisely defined external threats. Primary list of threats (including external threats) should be included in the safety policy in order to cover them with monitoring and preventive actions (i.e. we monitor the hurricane to secure the building).

In the next step, it is evaluated if a threat has a direct or indirect character. The case is, if the disruption in its essence relates to the organization, or it is a derivative factor that does, i.e.: if a demonstration is a disruption, or is it de facto the lack of access to the headquarters caused by the demonstration. Also in this case, the primary list of threats requires us to monitor and prevent, as a part of safety policy.

At the end, a final, verified list of threats is prepared, qualifying threats to be attended to within the safety policy and/or business continuity plan.

4.3 Analysis of disruption susceptibility of organization

This analysis is run with the use of “list of trouble spots” (see Table 5). First of all, the classification of objects’ categories has to be verified and specified in an appropriate way with regard to organization-specific situation.

Table 4. Model list of threats
(source: self study)

Groups / Threats
Natural disasters <ul style="list-style-type: none"> - earthquake - environmental contamination - flood - hurricane - lightening
Terrorism <ul style="list-style-type: none"> - blackmail - attack
Disruptions to physical working environment <ul style="list-style-type: none"> - lack of access to headquarters - building defect - too low / to high air temperature - to high air humidity - fire - flooding
Disruptions to functional working environment <ul style="list-style-type: none"> - strike - sabotage - employee unavailability - accident
Disruptions to technical working environment <ul style="list-style-type: none"> - lack of resources - Lack of power supply - A/C malfunction
Disruption to IT working environment <ul style="list-style-type: none"> - technical infrastructure/hardware: <ul style="list-style-type: none"> ▫ servers ▫ workstations ▫ supporting devices ▫ network devices ▫ cable system ▫ lack of connection to external networks - software: <ul style="list-style-type: none"> ▫ license expiration ▫ unauthorized deletion ▫ faulty functioning - viruses - data: <ul style="list-style-type: none"> ▫ loss or damage of data ▫ unauthorized access to data ▫ unauthorized copying of data ▫ unauthorized modification of data

Next, all the objects which may influence the continuity of business and information flow processes, in the light of processes and information flow channels, have to be identified for each location of organizational unit (headquarters + local and supporting locations). Some external services which have particularly high influence on the organizational functioning conditions have to be taken into consideration as objects, including universal ones such as: water, gas, electricity, telecommunications, as well as specific ones such as: cooperation, supply of resources or servicing. As a result of the analysis, separate, verified lists of trouble spots are prepared for each location.

4.4 Map of disruptions preparation

At this stage, map of disruptions for physical places as well as technical and logical objects, which could potentially be influenced by particular threats (Table: process – object – threat) is prepared. Owing to this process, the final verification of threats is possible. This verification reveals which threats could be most severe and which objects are most business-sensitive. Criticality should be evaluated and verified from the point of view of maintaining process stability.

This is the most extensive analytical document. However, if prepared carefully, it enables to introduce complex solutions for ensuring business continuity. It should not be feared, that this document will lead to as extensive scenarios and detailed policy for ensuring business continuity. In reality, the specific and not numerous scenarios and plans, which constitute the policy, will refer to many elements of map of disruptions simultaneously and cumulate into just a few general scenarios. Specific parts of the map of disruptions are connected with appropriate model approach to disruptions, consisting in one of the possibilities: T (tolerance of disruption), M (monitoring of disruption), P (preventing disruption), BCP (business continuity plan), which are described later.

4.5 Elaboration of regulations, procedures and instructions

We speak of a complex set of action procedures and instructions when there exists a norm which enables preparing them in such a way, that they will encompass each area of company activity and that the way they are formulated will be homogenous. Such a norm is constituted by regulations.

Table 5. Model list of trouble spots
(source: self study)

Category	Example
Structures	Own office building
Industrial, technical objects	factory, boiler station, computer room
Office centers	Rented office space
External technical equipment	External standalone power generator
Internal technical equipment	Indoor A/C or generator
IT infrastructure	IT hardware
External telecommunication devices	Satellite antenna on the roof
External services	Telecommunications
Logical objects of virtual objects/solutions	Intangible commitments

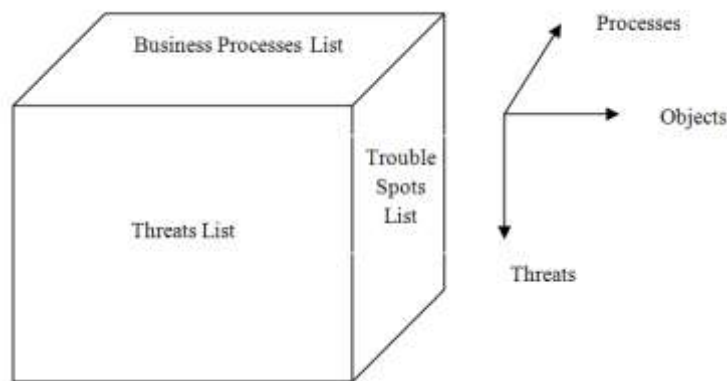

Figure 4. Map of disruptions
(source: self study)

Procedures are most often a written-down form of certain practice which is used and commonly viewed as appropriate. Only freshly established procedures are a record of bylaws. Procedures which exist some time and are verified appropriately often already encompass the experience factor and reflect real practices.

Complex set of procedures consists of different categories of documents, which regulate rules of actions and describe these actions. Procedures define the scope of rights, responsibilities, proper order of activities and bilateral relations between people and cells, which were entrusted with given fields of company activity. Instructions, on the other hand, are the documents which describe specific action steps of people and organizational cells.

In order to ensure completeness and coherence of procedures, both within one document and with regard to the complex set, a logical process for edition, verification and acceptance of procedures/instructions is required. The best way to ensure that is to create a sepa-

rate procedure/instruction, which defines model of such process and model structure of specific documents. Complex set of action procedures becomes, gradually, an inner norm of appropriate action and, at the same time, a basic point of reference for organizational audit.

Typical categories of documents, which constitute a complex set of bylaws, procedures and instructions are:

- bylaws,
- general procedures which refer to the whole organization,
- inter-department procedures which regulate cooperation and competences of two or more organizational cells,
- department procedures which encompass tasks delegated to a given organizational cells,
- instructions which describe actions regulated by procedures,
- self-contained instructions, which do not refer to any procedures.

Category division implies an appropriate process of establishing, verifying and accepting procedures and sets the proper organizational level for accepting them.

Covering all organizational activities with a complex set of procedures consists in determining problem matters, processes and sub-areas that need to be analyzed and regulated. This is made by choosing basic criteria of distinguishing problem matters and, possibly, superposition of some criteria. Typical criteria and divisions are:

- organizational structure,
- sub-systems of IT system,
- business continuity, safety, correct exploitation.

It is important to adopt a homogenous formatting of common procedures and to include in them all the information which identify the procedure (symbols), its history, processes of establishment, evaluation and acceptance.

Each procedure should have its owner, that is, a cell/post responsible for editing, directing, evaluating and distributing it after it is introduced. Usually, the appointed owner is the cell which actions are most similar to those regulated by the procedure or a central cell responsible for a set of procedures.

It is necessary to run an archive of all consecutive versions of each and every procedure. Such a need results, among others, from audit requirements, that should be able to refer each doubtful situation (problem) from the past to the norm which was in force at the time.

4.6 Realization of disruption tolerance approach

This approach encompasses those actions which have legal character but also those of organizational character. In general, there is no substantial reaction to disruption. Nevertheless, it is necessary to regulate a number of issues of two kinds.

First of all, it is necessary to determine in which way the disruption intensity is measured and who, in what way, on what basis, decides about launching actions, that are planned organizational reaction to disruption. Analogically, this person decides about ending this activity and returning to routine execution of tasks. Organizational activity, which in its nature means tolerating the disruption, consists in stopping routine work and may require informing all employees, clients, cooperators, etc. about it. This should be predicted within appropriate situation scenario.

Secondly, it is important that business responsibility towards partners (clients, employees and service-providers) is defined and limited adequately to the formulated policy.

It may consist in:

- placing contractual clauses defining the influence of “higher power” on the business responsibility for provided services,
- standardizing conditions of providing services (service level agreement), defining the acceptable level of service inaccessibility (e.g. 1 hour per year) or acceptable substitute solutions,
- clear definition of limitations of company solutions and responsibility for them (e.g. only until the communications centre of a public network),
- reserving the right to monitor or even intervene in partners’ solutions,
- grading scope, quality and price of services and their automatic limitation in case of disruption.

4.7 Realization of disruption monitoring approach

This approach encompasses, above all, organizational actions and, secondly, regulatory actions. Of key importance is the monitoring of disruption level and the fact if mechanism of routine compensation is satisfactory here. Establishing solutions of this policy consists in formal confirmation of organizational solutions concerning compensation of disruptions. Subsequently, it requires writing down, analyzing and, possibly, correcting or developing the existing practice as well as taking into consideration which solutions are necessary in the field of organizational structure design, tasks of particular cells, bylaws, procedures and instructions.

Table 6. Typical minor disruptions and their compensation
(source: self study)

Disruption	Compensation
- absence	- replacements
- unpunctual supplies	- inventories
- relative/ unclear decisions	- written orders/ confirmations
- equipment malfunction	- servicing attendants
- overloading	- repetition
- limited productivity/ capacity	- delays

The mentioned monitoring of disruptions should be regulated by procedures/instructions in such a way, that it is possible to evaluate and make decisions in situations when degree of disruption exceeds the limits of monitoring policy and should be confronted with the business continuity plan approach.

4.8 Realization of disruption prevention approach

This approach encompasses, above all, investment activities, but also, until the investment is realized, business continuity plan approach activities. The map of disruptions implies certain number of weaknesses of an organization (in the sense of business continuity problems). Most of these weaknesses may be limited or eliminated through investment in technical equipment. Typical investment directions are:

- doubling equipment,
- building back-up computer centers,
- multiplying the number of communication lines,
- multiplying access points to public services network,
- emergency sources of electricity,
- physical, energetic and logical separation of servers and IT centers,
- despite of specialization of servers, keeping the possibility of limiting the number of them being used,
- asynchronous process of securing data,
- specialists on duty.

An investment plan, accepted by the decision-makers responsible for technical solutions, is the fundamental document, on which the activities of this approach are based.

4.9 Realization of business continuity plan (approach)

It encompasses activities understood strictly in accordance with intuitive apprehension of goal and scope of ensuring business continuity. These activities are divided as follows:

The essence of business continuity plans are the situation scenarios. They are divided into:

- external scenarios, which describe possible versions of future development of events, on which the organization has no influence,

- internal scenarios, which reflect causal way of reasoning, that connects choice of action and the goal. Particular results are preferred by the organization in accordance with its hierarchy of goals (van der Heijden K., "Scenario Planning in Strategic Management").

Table 7. Task division in reacting to disruptions
(source: self study)

Organizational cell	Before occurrence of disruption	After occurrence of disruption
Permanent Anti-Crisis Team	Establishing business continuity plan	Analysis and improvement of business continuity plan
Crisis Team	Testing of business continuity plan	Ensuring business continuity, removing causes and effects of disruption

When working on scenarios, especially during first approach to create the business continuity plan, a very fundamental "top-down" way of thinking, which reaches to knowledge about organization and its goals, has to be adopted (traditional name for practice of describing, analyzing and solving problems). Consecutive steps of such reasoning (some of which can be omitted) are:

- establishing goals (even organizational mission),
- establishing the core organizational activities (core processes) on the basis of process analysis,
- establishing acceptable limitations to concessions in case of disruption (with regard to scope of necessary activities and minimum, yet accepted, quality of activity),
- evaluation of threats and disruptions which result from them (verification of disruption map),
- evaluation of current ability of organization to *ad hoc* react to disruptions,
- introduction of organizational solutions aimed at facing disruptions (appointing BCP Coordinator and Crisis Team and establishing proper bylaws, rights and obligations),
- establishing scenarios of disruptions and ways of counteracting them,
- testing of situations described in scenarios,
- verification of the above mentioned procedure on the basis of tests and conclusions drawn from the occurrence of disruption.

Model of situation scenario is shown in Figure 5. Situation scenarios:

- put our expectations in order,
- mobilize to concrete, precise reasoning and acting,
- enable simulation of critical situations and testing of elaborated plans.

Simultaneously, it is important to remember that scenarios:

- do not guarantee complete accuracy of expectations with regard to disruption, course of action of critical situations, adequacy of plans to real events,
- require leaving a flexible margin for unpredicted factors/events.

4.10 Dealing with disruptions

Implementation of policy of dealing with disruptions consists of three streams of activity:

- creating formal organizational structures,
- defining rules of monitoring threats and reacting to disruptions, investment plans and models of emergency scenarios,

- establishing bylaws, procedures and instructions, as well as detailed action scenarios in case of disruption.

Two aspects have to be considered with regard to organizational structures dedicated to business continuity management. First of all, the already signalized division into permanent, current execution of activities such as preparation and administration of business continuity ensuring policy (so called BCP Coordinator) and activation of Crisis Team. Secondly, experiences of risk management theory and good practices worked out in some industries, such as banking, have to be taken into account. In this context, disruptions to business continuity may be viewed, partially, as realization of business risk and, above all, operational risk.

Such approach leads to viewing the issue of ensuring business continuity as an element of operational management referred, above all, to supporting cells' activity, which ensures business cells the necessary technical, organizational, logistic and formal conditions of functioning.

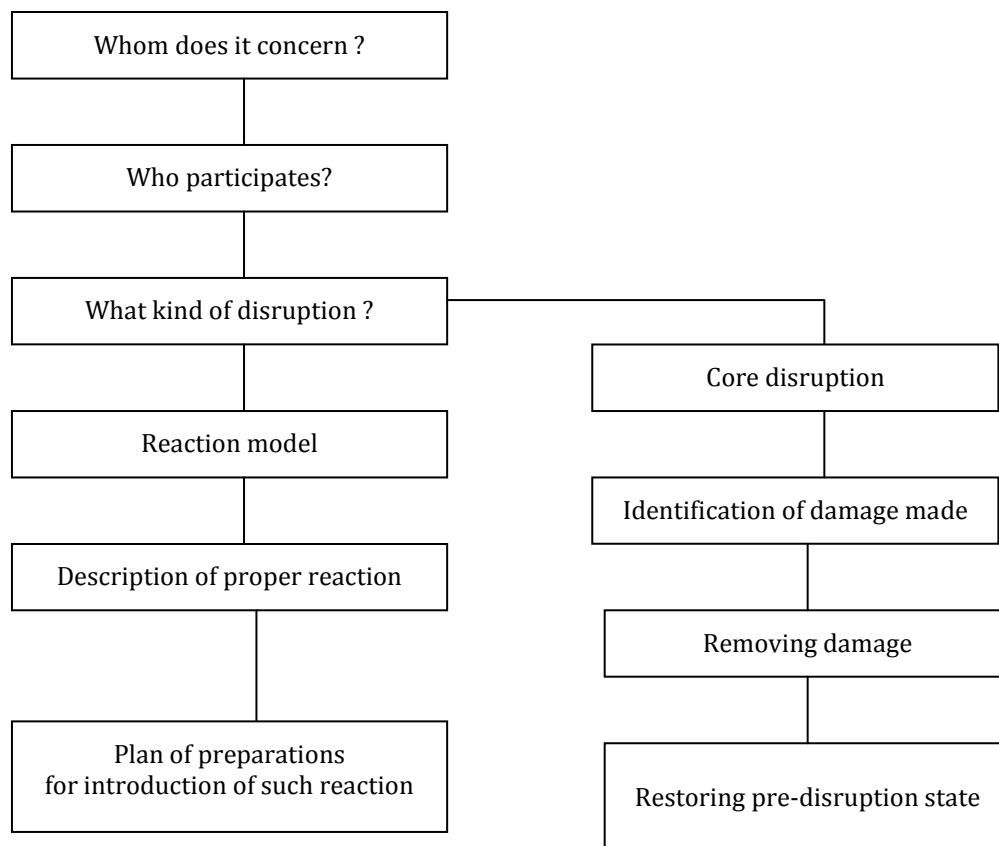

Figure 5. Scheme of situation scenario of reaction to disruption

(source: self study)

Implementation of policy for dealing with disruptions should be based on a few rules which are characterized below. First of all, it is important to aim at completely aware management of business continuity problems, through:

- identification of the core of organization activity,
- determining the hierarchy of importance of functions and processes,
- evaluation of determinants of ensuring business continuity including the cost factor,
- determining the acceptable limitations to concessions with regard to efficiency and quality of activity.

Secondly, in search of the right solutions, it is important to appreciate non-engineering means, because:

- technical solutions are complicated, most expensive but never completely effective,
- instead of technical solutions, it is more wise to search for legal and organizational ones.

Thirdly, it is very important to care for adequacy of solutions to real, current possibilities of the organization, as:

- already the execution of current activities uses, in fact, almost maximum capacity of organization,
- in face of disruption it is better to simplify the problem,
- in face of disruption it is better to limit the activity reasonably and according to a plan.

Fourthly, with regard to the above mentioned rules, solution simplicity should be pursued, because:

- each new solution brings about new threats,
- new solutions, especially technical ones, are also fallible,
- there always exists a threat of not being able to carry out a complicated solution.

Fifthly, intellectual power contained in human inventiveness should be appreciated. In order to do so, one must remember that:

- outstanding experts are reliable when it comes to extraordinary solutions, especially when disruption varies from the planned scenarios,
- person becomes a specialist through cumulating experiences and due to trainings,
- problems often appear on the touching edge of two specialties, and require knowledge of them,
- apart from specialists from within the organization, external consultants may be useful.

In implementation, it is important to remember that specific solutions of policy for dealing with disruptions should be introduced both for the whole organization and for its local branches. Simultaneously, one must consider looking at particular planned events and actions as well as documentation, which describes them, both from the perspective of the whole organization and from the perspective of individual organizational cells, identified as involved in given problem in the course of business processes' analysis. Planned scenarios of events and disruptions should also include variants depending on the time of disruption occurrence. Last but not least, one should not forget about the issue of restoring the situation from before the disruption.

4.11 Testing of business continuity plans

Situation scenarios are a proper basis for testing organizational readiness for facing the disruptions. Disruptions can be, for the sole purpose of tests, appropriately simulated or even deliberately induced.

Tests are an element of improving business continuity solutions and, therefore, should be planned regularly and as often as possible. First of all, they serve the purpose of checking solutions themselves, their adequacy to the situation, completeness, sufficiency of owned resources, reserves and qualifications. Secondly, they are used to train employees and organizational cells in applying planned scenarios and using emergency solutions.

Nevertheless, one must be very careful when running tests in real-life conditions and carry them out only after obtaining positive results of departmental and partial tests. In face of doubt concerning quality of preparations to tests or plan of test, it is better to postpone the test than to risk losing control over the situation.

When testing, one should gradually move from:

- partial tests to complex tests,
- tests in artificial conditions to tests in real-life conditions,
- tests in times when work is not performed to tests during normal work,
- tests including only chosen employees to tests including all employees.

It is extremely important to remember about testing the return from alternative work organization caused by

disruption to work organization from before its occurrence.

4.12 Constant improvement

One fundament of organizational culture is not to finish with currently elaborated and implemented solutions, but to constantly consider them imperfect and work on their improvement and development. It is also clearly stated rule included in the new generation of quality standards (See PN-ISO-9001:2000). It refers solely to business continuity management.

When following such approach, it is necessary to appoint a Permanent Anti-Crisis Team, the most general task of which is to elaborate and constantly improve the solutions devoted to ensuring business continuity. Simultaneously, a direct, substantive improvement of solutions is required, based on testing and careful analysis of their adequacy to actual disruptions of business continuity.

The space for improvement is considerable, which results from realistic design of solutions, both with regard to rational limits of concessions in face of an aggressive disruption and modest, defensive evaluation of own capabilities of reacting to disruptions. In general, the more modest the expectations towards the scope of business continuity ensuring solutions' effects, the higher the effectiveness of implementation of primary versions of solutions, but also, the bigger the area for gradual improvement.

A number of improvement techniques are devoted to this idea (Dahlgaard J.J., Kristensen K., Gopal K.K. „Fundamentals of Total Quality Management", pp. 59-67.) in the sense of analysis of causes of insufficient quality and determining ways of reaching better solutions. Basis for this improvement are people, their knowledge and involvement, which can be shaped, and effective organization, which can be established and developed.

5 Summary

First of all, business continuity is a postulate of business system perfection, where business system refers to each and every organization, thus to all economic or administrative entities. In this sense, ensuring business continuity is the subject of strategic management, putting forward the primary goal of organizational

efficiency and taking over the field of operational risk management.

Secondly, business continuity is viewed as such organization behavior which creates the ability of an organization to effectively react to disruption as a result of a specific interaction between signs of threat and inner organization's vulnerability, infrastructure or resources. In this sense, ensuring business continuity is the subject of operational management and is the last cell of operational risk management.

In general, business continuity is the ability of an organization to react to disruptions in normal business conditions in such a way to, where it is possible, restore those normal conditions and, where it is not, to switch to a planned method of alternate execution of actions. Therefore, business continuity is viewed both in the context of organization tasks and processes for realization of these tasks, as well as in the context of factors which may disturb those processes and organization vulnerabilities, which determine its disruption sensitivity.

6 References

- [1] Andersen B. - *Benchmarking* [in] Performance Management (ed. A. Rolstadas). Chapman & Hall, London 1995.
- [2] Antoszkiewicz J.D. - *Firma wobec zagrożeń. Identyfikacja zagrożeń*. Poltext, Warszawa 1998.
- [3] Augustyn S. - *Praca menedżera programów kryzysowych na lokalnych szczeblach zarządzania* [in] Samorząd terenowy wobec nadzwyczajnych zagrożeń. Bydgoszcz 1998.
- [4] Dahlgaard J.J., Kristensen K., Gopal K.K. - *Podstawy zarządzania jakością*. PWN, Warszawa 2000.
- [5] Dworzecki Z. - *Skuteczne zarządzanie w sytuacjach kryzysu*. TNOiK, Warszawa 1993.
- [6] *Guide to Business Continuity Management*. British Standards Institution, 2003.
- [7] Heath R.L. - *Crisis Management for Managers and Executives*. Financial Times Pitman Publishing, London – San Francisco 1998.
- [8] van der Heijden K. - *Planowanie scenariuszowe w zarządzaniu strategicznym*. Oficyna Ekonomiczna, Kraków 2000.
- [9] Hiles A. - *Service Level Agreements: Measuring Cost and Quality in Service Relationships*. Chapman & Hall, London 1993.

- [10] Hiles A., Bearnese P. - *The Definitive Handbook of Business Continuity Management*. John Wiley & Sons Ltd, Baffins Lane - Chichester 1999.
- [11] Mitroff I.I., Pearson C.M. - *Zarządzanie sytuacją kryzysową*. Business Press, Warszawa 1998.
- [12] Rummier G.A., Brache A.P. - *Podnoszenie efektywności organizacji*. PWE, Warszawa 2000.
- [13] Tyrała P. - *Zarządzanie kryzysowe*. Wydawnictwo Adam Marszałek, Toruń 2001.
- [14] Zawila-Niedzwiecki J. - *Metoda TSM-BCP - Total Security Management, Business Continuity Planning*. European Network Security Institute, Warszawa 2003.
- [15] Zawila-Niedzwiecki J. - *Propozycja metodyki zarządzania ciągłością działania* [in] Przegląd Organizacji, No. 6, 2003.
- [16] Zawila-Niedzwiecki J. - *Ciągłość działania a teoria zarządzania* [in] *Ekonomika i Organizacja Przedsiębiorstwa*, No. 4, 2006.
- [17] Zawila-Niedzwiecki J. - *Problem dobrych praktyk zarządzania ciągłością działania w instytucjach finansowych* [in] *Komputerowo zintegrowane zarządzanie* (ed. R. Knosala). Wydawnictwo Politechniki Opolskiej, Opole 2007.
- [18] Zawila-Niedzwiecki J. - *Model oceniania dojrzałości zarządzania ciągłością działania organizacji* [in] *Przegląd Organizacji*, No. 4, 2007.
- [19] Zawila-Niedzwiecki J. - *Dobre praktyki czy teoria zapewniania ciągłości działania* [at] Ogólnopolska Konferencja Naukowa nt. Zarządzanie rozwojem organizacji, Politechnika Łódzka Katedra Zarządzania, Spała 10-12.05.2007.
- [20] Zawila-Niedzwiecki J. - *Projektowanie rozwiązań zapewniania ciągłości działania* [at] Konferencja Management Forum 2020 nt. Współczesne i perspektywiczne kierunki badań w zarządzaniu przedsiębiorstwem, Akademia Ekonomiczna w Katowicach, Ustroń 9-10.05.2007.
- [21] Zawila-Niedzwiecki J. - *Business Continuity Management, from best practices to maturity model* [at] 11th International Conference on Human Aspects of Advances Manufacturing: Agility and Hybrid Automation, University of Louisville + International Ergonomics Association + Politechnika Poznańska, Poznań + San Diego 9-12.07.2007.
- [22] Zawila-Niedzwiecki J. - *Rozwiązania bezpieczeństwa i ciągłości działania w doskonaleniu organizacji* [at] Konferencja nt. Potencjał restrukturyzacji w warunkach globalizacji i nowej gospodarki. Akademia Ekonomiczna w Katowicach, Katedra Ekonomiki i Organizacji Przedsiębiorstw, 17-20.10.2007.
- [23] Zawila-Niedzwiecki J. - *Metoda TSM-BCP projektowania rozwiązań zapewniania ciągłości działania organizacji* [at] X Jubileuszowa Międzynarodowa Konferencja Naukowa nt. Zarządzanie przedsiębiorstwem. Teoria i praktyka, Akademia Górniczo-Hutnicza Wydział Zarządzania, Kraków 22-23.11.2007.

Information for Authors

Content of an article. A paper may describe original work, discuss a new method or application, or present a survey of recent work in a given field. Concepts and underlying principles should be emphasized, with enough background information to orient the reader who is not a specialist in the subject. A paper submitted to the Journal should not have been published elsewhere, including the World Wide Web, nor should it be submitted to another publication or to a conference concurrently.

Submission process. An article, prepared in MS Word, should be sent to Editor-in-Chief: prof. Tadeusz KRUPA, Faculty of Management, Warsaw University of Technology, ul. Narbutta 85, 02-524 Warszawa, Poland, e-mail: T.Krupa@wz.pw.edu.pl.

Review process. All manuscript are sent to two independent reviewers to ensure both accuracy and relevance to the journal. The final decision on acceptance will be made by the Editor-in-Chief.

Text. The manuscript must be produced clearly on plain A4-sized sheets - 210 by 297 mm. Set top and bottom margins for the pages at 25 mm. Set right and left margins as mirror margins with inside margin at 20 mm and outside margin at 16 mm. The body text must be printed in double columns with the middle margin of 8 mm. The body text is typed in 10,5pt Times New Roman with 1,15 multiple line spacing and 4pt spacing after paragraph. The title page should include the title of manuscript, author(s), affiliation(s), abstract (8 - 12 sentences) and key words (8 - 12 characteristic words).

References. References should be quoted in the text using consecutive numbers in square brackets, alternatively, as shown here [1, pp. 7-12], or [2, 4], or [1-3]. At the end of the manuscript, they should be cited as follows:

The monograph:

Author(s) - *Title of the monograph*. Publishing company, City and the year of the publication.

The example:

[1] Poe V., Klauer P., Brobst S. - *Building a Data Warehouse for Decisial Support*. Prentice-Hall Inc., New York 1998.

The monograph under the editing:

Author(s) (ed.) - *Title of the monograph*. Publishing company, City and the year of the publication.

The example:

[2] Ansoff H.I. (ed.) - *Corporate Strategy*. McGraw-Hill, New York 1965.

The chapter of the monograph under the editing:

Author(s) - *Title of the chapter* [in] *Title of the monograph* (ed. Authors). Publishing company, City and the year of the publication, numbers of pages.

The example:

[3] Wilson D.C. - *Organizational Structures in the Voluntary Sector* [in] *Issues in Voluntary and Non Profit Management* (ed. J. Batsleer, C. Cornforth, R. Paton). Addison-Wesley, Wokingham 1992, pp. 45-93.

The article in the journal:

Author(s) - *Title of the article* [in] Title of the journal, Volume, Number, year, numbers of pages.

The example:

[4] Barney J. - *Organizational culture: can it be a source of sustained competitive advantage?* [in] Academy of Management Journal, Vol. 28, No. 7, 1986, pp. 56-65.

The paper at the conference:

Author(s) - *Title of the paper* [at] Title of the conference, City and the year of the conference, numbers of pages.

The example:

[5] Bonits N. - *Intellectual Capital: An Exploratory Study that Develops Measures and Models* [at] The First Management Decision Conference, London 1998, pp. 12-20.

Editorial Office:

Teresa Ostrowska, email: T.Ostrowska@wz.pw.edu.pl

Katarzyna Rostek, email: K.Rostek@wz.pw.edu.pl

Faculty of Management

Warsaw University of Technology

ul. Narbutta 85, 02-524 Warszawa, Poland