

# The Fourth International Workshop on Rough Sets, Fuzzy Sets, and Machine Discovery

*Proceedings*

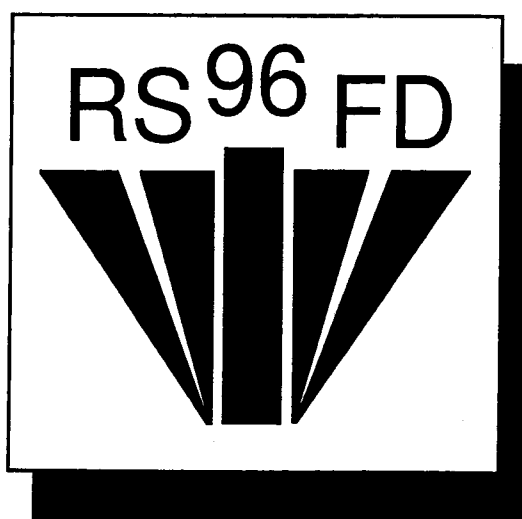

*Edited by*  
*Shusaku Tsumoto,*  
*Satoshi Kobayashi,*  
*Takashi Yokomori,*  
*Hiroshi Tanaka,*  
*and*  
*Akira Nakamura*

# THE FOURTH INTERNATIONAL WORKSHOP ON ROUGH SETS, FUZZY SETS AND MACHINE DISCOVERY (RSFD'96)

Sanjoh Conference Hall, The University of Tokyo  
Hongo, Tokyo, JAPAN  
November 6-8, 1996

Web Page: <http://ylab-gw.cs.uec.ac.jp/RSFD96.html>  
Email: [rsfd96@mri.tmd.ac.jp](mailto:rsfd96@mri.tmd.ac.jp)

**Sponsored by:** Information Processing Society of Japan  
**In Cooperation with:** \*International Rough Set Society  
\*Institute of Electronics, Information and  
Communication Engineers of Japan  
\*Japanese Society for Artificial Intelligence  
\*Society of Instrument and Control Engineers of Japan  
\*Japan Society for Fuzzy Theory and Systems  
\*Japan Research Group on Multiple-Valued Logic  
**Supported by:** \*Inoue Foundation for Science  
\*The Telecommunications Advancement Foundation  
\*Tokyo Medical and Dental University,  
Center for Computational Medicine

## Honorary Chairs

Zdzislaw Pawlak and Lotfi A. Zadeh

Program Chair: Akira Nakamura  
Program Co-chair: Masao Mukaidono  
General Chairs: Wojciech Ziarko and T.Y. Lin  
Organizing Chair: Hiroshi Tanaka  
Local Chair: Shusaku Tsumoto  
Publicity: Y.Y. Yao, North America  
J. Stefanowski, Europe  
T. Yokomori, Asia

## Program Committee

James Bezdek, University of West Florida, U.S.A.  
Nick Cercone, University of Regina, Canada  
Didier Dubois, Universite Paul-Sabatier CNRS, France  
Jerzy Grzymala-Busse, University of Kansas, U.S.A.  
Mitsuru Ishizuka, The University of Tokyo, Japan  
Willi Kloesgen, GMD, Germany  
Satoshi Kobayashi, The University of Electrocommunication,  
Japan  
Shigenobu Kobayashi, Tokyo Institute of Technology, Japan  
T.Y. Lin, San Jose State University, U.S.A.  
Ryszard Michalski, George Mason University, U.S.A.  
Masao Mukaidono, Meiji University, Japan  
Toshinori Munakata, Cleveland State University, U.S.A.  
Hiroshi Motoda, Osaka Univeristy, Japan  
Kaoru Hirota, Tokyo Institute of Technology, Japan  
Masahiro Inuiguchi, Hiroshima University, Japan  
Kazuo Nakamura, Nagaoka University of Technology, Japan  
Charles Nguyen, Catholic University of America, U.S.A.  
Masayuki Numao, Tokyo Institute of Technology, Japan

Zdzislaw Pawlak, Warsaw University of Technology, Poland  
Zbigniew Ras, University of North Carolina, U.S.A.  
Andrzej Skowron, Warsaw University, Poland  
Gregory Piatetsku-Shapiro, GTE Laboratories, U.S.A.  
Krzysztof Slowinski, K.Marcinkowski University of  
Medical Sciences, Poland  
Roman Slowinski, Technical University of Poznan, Poland  
Jerzy Stefanowski, Technical University of Poznan, Poland  
Roman Swiniarski, San Diego State University, U.S.A.  
Hideo Tanaka, University of Osaka Prefecture, Japan  
Raul Valdes-Perez, Carnegie Mellon Unicersity, U.S.A.  
Anita Wasilewska, State University of New York, U.S.A.  
Michael Wong, University of Regina, Canada  
Yiyu Yao, Lakehead University, Canada  
Takahira Yamaguchi, Shizuoka University, Japan  
Wojciech Ziarko, University of Regina, Canada  
Jan Zytkow, Wichita State University, U.S.A.

# Data versus Logic A Rough Set View

Zdzisław Pawlak

zpw@ii.pw.edu.pl

Institute of Theoretical and Applied Informatics  
Polish Academy of Sciences  
ul. Baltycka 5, 44 000 Gliwice, Poland

**Abstract:** *In this paper we consider some aspects of decision rule generation methods based on rough set theory. Particularly, we propose to associate with every set of decision rules a connection graph, similar to that used in switching theory, so that sets of decision rules can be represented as a kind of a switching circuit, which depicts relations between decision rules. The connection graph can be understood as a visual representation (explanation) of relations in data, or as a specification of a discrete dynamic system (e.g., controller, program, etc.). The connection graph can be also viewed as an alternative to the well known Petri Nets concept for concurrent systems analysis.*

**Keywords:** Rough sets, decision rules, connection graph, Petri Nets.

## 1 Introduction

The paper contains a discussion on the relationship between data and its logical representation in a form of a decision rules – from the rough set perspective.

The rough set concept has been introduced by the author in [14]. Rough set theory has developed during the past fourteen years to a mature discipline with many real-life applications to its credit, e.g., medicine, pharmacology, market analysis, engineering, pattern recognition, data bases and many others [2,3,6,7,8,9,10,11,13,17,20,22,23,27,30,31,33]. Basics of rough set theory can be found in [15,16,21,25].

Data can represent results of observations, measurements, knowledge of an agent or group of agents, etc. Decision rules derived from data reveal hidden patterns in the data, and can be understood as description of laws governing the observed phenomena or processes. In other words decision rules are meant to represent a "cause-effect" relations in the observed process. It is well known that a relationship between data not necessarily implies corresponding relationship in reality. We will however refrain from philosophical discussion of this issue here.

The topic of discovering rules from data has been pursued for a long time in statistics, but many new methodologies based on some AI techniques, e.g., machine learning, data mining, emerged recently. Rough sets proved to be a valuable tool in this area as well, and many rough set based methods of rule induction from data have been developed [1,5,18,24,26,28,29,34].

In this paper we are going to analyze decision rule generation methods based on rough set theory. Besides, with every set of decision rules a connection graph will be associated. To this end notation similar to that used in the switching theory will be employed,

so that the set of decision rules can be represented as a switching circuits, which depicts relations between decision rules. The connection graph can be understood as an visual representation (explanation) of the relations in data or as a specification of a discrete dynamic system (e.g., controllers).

Decision tables are used in software engineering [12] for program specification. It seems that the rough set approach can be as well employed to this aim.

The presented approach can be also seen as an alternative to the well known Petri Nets model of concurrent system behaviour [19].

## 2 Information Tables, Decision Tables and Decision Rules

Data are often represented as a table, columns of which are labeled by *attributes*, rows by *objects* of interest and entries of the table are *attribute values*. Such tables are known as *information systems*, *attribute-value tables* or *information tables*. We will use here the term *information table*. Below an example of information table is shown.

Suppose we are given data about 6 patients, as shown in Table 1.

Patient	Headache	Muscle-pain	Temperature	Flu
p1	no	yes	high	yes
p2	yes	no	high	yes
p3	yes	yes	very high	yes
p4	no	yes	normal	no
p5	yes	no	high	no
p6	no	yes	very high	yes

Table 1

Columns of the table are labelled by attributes (symptoms) and rows – by objects (patients), whereas entries of the table are attribute values. Thus each row of the table can be seen as information about specific patient. For example, patient p2 is characterized in the table by the following attribute-value set:

(Headache, yes), (Muscle-pain, no), (Temperature, high), (Flu, yes),

which form information about the patient.

Sometimes we distinguish in an information table two classes of attributes, called *condition* and *decision* (*action*) attributes. For example in Table 1 attributes Headache, Muscle-pain and Temperature can be considered as condition attributes, whereas the attribute Flu – as a decision attribute.

Each row of a decision table determines a *decision rule*, which specifies *decisions* (*actions*) that should be taken when conditions pointed out by *condition* attributes are satisfied. For example in Table 1 the condition (Headache, no), (Muscle-pain, yes), (Temperature, high) determines uniquely the decision (Flu, yes). Decision rules are often presented as implications and are called "if... then..." rules. For example, rule 1) in Table 1 can be presented as implication

if (Headache, no) and (Muscle-pain, yes) and (Temperature, high), then (Flu, yes).

With each decision table we can associate the set of all decision rules determined by the table. Hence with Table 1 we can associate the following decision rules:

if (Headache, no) and (Muscle-pain, yes) and (Temperature, high), then (Flu, yes);

if (Headache, yes) and (Muscle-pain, no) and (Temperature, high), then (Flu, yes);

if (Headache, yes) and (Muscle-pain, yes) and (Temperature, very high), then (Flu, yes);

if (Headache, no) and (Muscle-pain, yes) and (Temperature, normal), then (Flu, no);

if (Headache, yes) and (Muscle-pain, no) and (Temperature, high), then (Flu, no);

if (Headache, no) and (Muscle-pain, yes) and (Temperature, very high), then (Flu, yes).

Decision rules 2) and 5) in Table 1 have the same conditions but different decisions. Such rules are called *inconsistent* (*nondeterministic*, *conflicting*); otherwise the rules are referred to as *consistent* (*deterministic*, *nonconflicting*). Sometimes consistent decision rules are called *sure* (*certain*) rules, and inconsistent rules are called *possible* rules. Decision tables containing inconsistent decision rules are called *inconsistent* (*nondeterministic*, *conflicting*); if the table do not contain inconsistent rules it is called *consistent* (*deterministic*, *nonconflicting*).

The number of consistent rules to all rules in a decision table can be used as a *consistency measure* of the decision table, and will be denoted by  $\gamma(C, D)$ , where  $C$  and  $D$  are sets of condition and decision attributes respectively. Thus if  $\gamma(C, D) = 1$ , the decision table is consistent, and if  $\gamma(C, D) \neq 1$  the decision table is inconsistent. For example for Table 1,  $\gamma(C, D) = 4/6$ .

Notice the distinction between decision tables and the corresponding set of decision rules. A decision table is a collection of data, whereas decision rules are implications, e.g., logical expressions. To deal with data we use various mathematical methods, e.g., statistics, but to analyze implications we must employ logical tools.

### 3 Rough Sets and Approximations

The starting point of rough set theory is an indiscernibility relation, generated by information about objects of interest. The indiscernibility relation is intended to express the fact that due to the lack of knowledge we are unable to discern some objects employing the available information. Let us illustrate this idea by an example.

In Table 1 patients p2, p3 and p5 are indiscernible with respect to the attribute Headache, patients p3 and p6 are indiscernible with respect to attributes Muscle-pain and Flu, and patients p2 and p5 are indiscernible with respect to attributes Headache, Muscle-pain and Temperature.

Patient p2 has flu, whereas patient p5 does not. Because they are indiscernible with respect to the attributes Headache, Muscle-pain and Temperature, hence flu cannot be characterized in terms of attributes Headache, Muscle-pain and Temperature. The remaining patients p1, p3 and p6 display symptoms which enable us to classify them with certainty as having flu, patients p2 and p5 cannot be excluded as having flu and patient p4 for sure does not have flu, in view of the displayed symptoms.

Now we present above considerations more formally.

Suppose we are given two finite, non-empty sets  $U$  and  $A$ , where  $U$  is the *universe*, and  $A$  – a set *attributes*. With every attribute  $a \in A$  we associate a set  $V_a$ , of its *values*, called the *domain* of  $a$ . Any subset  $B$  of  $A$  determines a binary relation  $I(B)$  on  $U$ , which will be called an *indiscernibility relation*, and is defined as follows:

$xI(B)y$  if and only if  $a(x) = a(y)$  for every  $a \in A$ , where  $a(x)$  denotes the value of attribute  $a$  for element  $x$ .

Obviously  $I(B)$  is an equivalence relation. The family of all equivalence classes of  $I(B)$ , i.e., partition de-

terminated by  $B$ , will be denoted by  $U/I(B)$ , or simple  $U/B$ ; any equivalence class of  $I(B)$ , i.e., the block of the partition  $U/B$ , containing  $x$  will be denoted by  $B(x)$ .

If  $(x, y)$  belongs to  $I(B)$  we will say that  $x$  and  $y$  are  $B$ -indiscernible. Equivalence classes of the relation  $I(B)$  (or blocks of the partition  $U/B$ ) are referred to as  $B$ -elementary sets. In the rough set approach the elementary sets are the basic building blocks (concepts) of our knowledge about reality.

The indiscernibility relation will be used to define the following two operations on sets

$$B_*(X) = \{x \in U : B(x) \subseteq X\},$$

$$B^*(X) = \{x \in U : B(x) \cap X \neq \emptyset\},$$

assigning to every subset  $X$  of the universe  $U$  two sets  $B_*(X)$  and  $B^*(X)$ , called the  $B$ -lower and the  $B$ -upper approximation of  $X$ , respectively. The set

$$BN_B(X) = B^*(X) - B_*(X)$$

will be referred to as the  $B$ -boundary region of  $X$ .

If the boundary region of  $X$  is the empty set, i.e.,  $BN_B(X) = \emptyset$ , then  $X$  is *crisp (exact)* with respect to  $B$ ; in the opposite case, i.e., if  $BN_B(X) \neq \emptyset$ ,  $X$  is referred to as *rough (inexact)* with respect to  $B$ .

For example, the lower approximation of the set "flu" = {p1, p2, p3, p6}, is {p1, p3, p6}, the upper approximation of this set is {p1, p2, p3, p5, p6}, whereas the boundary region is {p2, p5}. Similarly p4 does not have flu and p2, p5 cannot be excluded as having flu, thus the lower approximation of "not flu" = {p4, p5} is {p4}, the upper approximation - is {p2, p4, p5}, and the boundary region is {p2, p5}.

## 4 Dependency of Attributes

Another important issue in data analysis is discovering dependencies between attributes. Intuitively, a set of attributes  $D$  depends totally on a set of attributes  $C$ , denoted  $C \Rightarrow D$ , if all values of attributes from  $D$  are uniquely determined by values of attributes from  $C$ . In other words,  $D$  depends totally on  $C$ , if there exists a functional dependency between values of  $D$  and  $C$ . In Table 1 there are not total dependencies whatsoever. If in Table 1, the value of the attribute Temperature for patient p5 were "no" instead of "high", there would be a total dependency  $\{\text{Temperature}\} \Rightarrow \{\text{Flu}\}$ , because to each value of the attribute Temperature there would correspond unique value of the attribute Flu.

Formally dependency can be defined in the following way. Let  $D$  and  $C$  be subsets of  $A$ . We say that  $D$  depends totally on  $C$ , if and only if  $I(C) \subseteq I(D)$ . That means that the partition generated by  $C$  is finer than the partition generated by  $D$ . Notice, that the

concept of dependency discussed above corresponds to that considered in relational databases.

We would need also a more general concept of dependency of attributes, called a *partial dependency* of attributes. Let us first depict the idea by example, referring to Table 1. In this table, for example, the attribute Temperature determines uniquely only some values of the attribute Flu. That is, (Temperature, very high) implies (Flu, yes), similarly (Temperature, normal) implies (Flu, no), but (Temperature, high) does not imply always (Flu, yes). Thus the partial dependency means that only some values of  $D$  are determined by values of  $C$ .

Formally, the above idea can be formulated as follows. Let  $D$  and  $C$  be subsets of  $A$ . We say that  $D$  depends in degree  $k$ ,  $0 \leq k \leq 1$ , on  $C$ , denoted  $C \Rightarrow_k D$ , if

$$k = \frac{|POS_C(D)|}{|U|},$$

where

$$POS_C(D) = \bigcup_{X \in U/D} C_*(X).$$

The expression  $POS_C(D)$ , called a *positive region* of the partition  $U/D$  with respect to  $C$ , is the set of all elements of  $U$  that can be uniquely classified to blocks of the partition  $U/D$ , by means of  $C$ . It can be easily seen that  $k$  can be interpreted as the consistency measure  $\gamma(C, D)$ .

Thus the coefficient  $k$  expresses the ratio of all elements of the universe, which can be properly classified to blocks of the partition  $U/D$ , employing set of attributes  $C$ . Notice that for  $k = 1$  we get the previous definition of total dependency.

Obviously, a decision table is consistent if and only if  $k = 1$ , otherwise, i.e., if  $k \neq 1$ , the decision table is inconsistent; if  $k = 0$  we will say that the decision table is *totally inconsistent*.

For example, for dependency  $\{\text{Headache, Muscle-pain, Temperature}\} \Rightarrow \{\text{Flu}\}$  we get  $k = 4/6 = 2/3$ , because four out of six patients can be uniquely classified as having flu or not, employing attributes Headache, Muscle-pain and Temperature.

If we were interested how exactly patients can be diagnosed using only the attribute Temperature, that is - in the degree of the dependence  $\{\text{Temperature}\} \Rightarrow \{\text{Flu}\}$ , we would get  $k = 3/6 = 1/2$ , since in this case only three patients p3, p4 and p6 out of six can be uniquely classified as having flu. In contrast to the previous case patient p4 cannot be classified now as having flu or not. Hence the single attribute Temperature offers worse classification than the whole set of attributes Headache, Muscle-pain and Temperature. It is interesting to observe that neither Headache nor Muscle-pain can be used to recognize flu, because for both dependencies  $\{\text{Headache}\} \Rightarrow \{\text{Flu}\}$  and  $\{\text{Muscle-pain}\} \Rightarrow \{\text{Flu}\}$  we have  $k = 0$ , i.e., the table is totally inconsistent.

## 5 Reduction of Attributes and Values of Attributes

We often face a question whether we can remove some data from a data-table preserving its basic properties.

Suppose we are given a dependency  $C \Rightarrow_k D$ . It may happen that  $D$  depends not on the whole set  $C$  but on its proper subset  $C'$ . In order to investigate this problem we need the notion of a reduct, which will be defined and discussed next.

Let  $C, D \subseteq A$  be a condition and decision attributes respectively.

- We will say that attribute  $a \in C$  is *D-dispensable* in  $C$ , if  $POS_C(D) = POS_{(C-\{a\})}(D)$ ; otherwise the attribute  $a$  is *D-indispensable* in  $C$ .
- If all attributes  $a \in C$  are *C-indispensable* in  $C$ , then  $C$  will be called *D-independent*.
- Subset  $C' \subseteq C$  is a *D-reduct* (a reduct with respect to  $D$ ) of  $C$ , iff  $C'$  is *D-independent* and  $POS_C(D) = POS_{C'}(D)$ .

For example in Table 1 there are two reducts with respect to Flu: {Headache, Temperature} and {Muscle-pain, Temperature}. That means that either the attribute Headache or Muscle-pain can be eliminated from the table and consequently instead of Table 1 we can use either

Patient	Headache	Temperature	Flu
p1	no	high	yes
p2	yes	high	yes
p3	yes	very high	yes
p4	no	normal	no
p5	yes	high	no
p6	no	very high	yes

Table 2

or

Patient	Muscle-pain	Temperature	Flu
p1	yes	high	yes
p2	no	high	yes
p3	yes	very high	yes
p4	yes	normal	no
p5	no	high	no
p6	yes	very high	yes

Table 3

For further simplification of decision tables we will need also a concept of a *value reduct*. Suppose we are given a dependency  $C \Rightarrow D$ , where  $C$  is a *D-reduct* of  $C$ .

- We say that value of attribute  $a \in C$ , is *D-dispensable* for  $x \in U$ , if

$$C(x) \subseteq D(x) \text{ implies } C'_a(x) \subseteq D(x),$$

where  $C'_a = C - \{a\}$ ;

otherwise the value of attribute  $a$  is *D-indispensable* for  $x$ :

- If for every attribute  $a \in C$  value of  $a$  is *D-indispensable* for  $x$ , then  $C$  will be called *D-independent* for  $x$ .
- Subset  $C' \subseteq C$  is a *D-reduct* of  $C$  for  $x$  (a value reduct), iff  $C'$  is *D-independent* for  $x$  and

$$C(x) \subseteq D(x) \text{ implies } C'(x) \subseteq D(x).$$

Using the concept of a value reduct, Table 2 and Table 3 can be simplified as follows

Patient	Headache	Temperature	Flu
p1	no	high	yes
p2	yes	high	yes
p3	-	very high	yes
p4	-	normal	no
p5	yes	high	no
p6	-	very high	yes

Table 4

Patient	Muscle-pain	Temperature	Flu
p1	yes	high	yes
p2	no	high	yes
p3	-	very high	yes
p4	-	normal	no
p5	no	high	no
p6	-	very high	yes

Table 5

where "-" denotes "don't care values".

We can also present the obtained results as a set of decision rules.

For Table 4 we get

if (Headache, no) and (Temperature, high), then (Flu, yes);

if (Headache, yes) and (Temperature, high), then (Flu, yes);

if (Temperature, very high), then (Flu, yes);

if (Temperature, normal), then (Flu, no);

if (Headache, yes) and (Temperature, high), then (Flu, no);

if (Temperature, very high), then (Flu, yes);

and for Table 5 we have

if (Muscle-pain, yes) and (Temperature, high), then (Flu, yes);

if (Muscle-pain, no) and (Temperature, high), then (Flu, yes);

if (Temperature, very high), then (Flu, yes);

if (Temperature, normal), then (Flu, no);

if (Muscle-pain, no) and (Temperature, high), then (Flu, no);

if (Temperature, very high), then (Flu, yes).

## 6 Decision Rules and Connection Graph

Suppose we are given data obtained from observation of certain processes, phenomena etc. Our task is to find out, on the basis of observed data, rules governing the perceived process. That means that we have to find all (or some) decision rules which describe relationship between data. This will be called explanation of data. For example, let us consider Table 1. It follows from this example that the decision rules (Muscle-pain, no) implies (Temperature-high), (Headache, no) implies (Muscle-pain, yes), (Temperature-high) implies (Flu, yes) are valid in the table.

For simplicity of notation let us replace Table 1, by Table 6

	<i>a</i>	<i>b</i>	<i>c</i>	<i>d</i>
1	0	1	1	1
2	1	0	1	1
3	1	1	2	1
4	0	1	0	0
5	1	0	1	0
6	0	1	2	1

Table 6

where attributes Headache, Muscle-pain, Temperature and Flu are replaced by letters *a*, *b*, *c* and *d* respectively, and values of attributes are replaced by numbers 0,1 and 2 in an obvious way.

More precisely, by explanation we will understand here finding all simple minimal decision rules from data. By a simple decision rule we mean the rule having only one decision attribute, and a decision rule is minimal if all its condition attribute-value pairs are reduced with respect to the decision attribute.

In order to solve this problem we have to compute all partial dependencies of the form  $(A - \{\alpha\}) \Rightarrow \{\alpha\}$  for all  $\alpha \in A$  and compute all minimal decision rules corresponding to these dependencies. To this end we have to find out all value reducts of each set of attributes  $A - \{\alpha\}$  for each object belonging to  $POS_{(A - \{\alpha\})}(\alpha)$ .

For the attribute *a* we get:

$$\begin{aligned} RED_a^1\{b, c, d\} &= \{b, c\}, \\ RED_a^2\{b, c, d\} &= \{b\}, \\ RED_a^4\{b, c, d\} &= \{c\}, \{b, d\}, \\ RED_a^5\{b, c, d\} &= \{b\}, \{c, d\}. \end{aligned}$$

$RED_a^1\{b, c, d\} = \{b, c\}$  means that the attribute-value pairs  $b_1, c_1$  determine uniquely attribute-value pair  $a_0$ , i.e., that the decision rule

$$b_1c_1 \rightarrow a_0$$

is valid. Proceeding similarly we get following decision rules:

$$\begin{aligned} b_0 &\rightarrow a_1, \\ c_0 &\rightarrow a_0, \\ b_1d_0 &\rightarrow a_0, \\ c_1d_0 &\rightarrow a_1. \end{aligned}$$

In the same way for the attribute *b* we get

$$\begin{aligned} RED_b^1\{a, c, d\} &= \{a\}, \\ RED_b^2\{a, c, d\} &= \{a, c\}, \\ RED_b^3\{a, c, d\} &= \{c\}, \\ RED_b^4\{a, c, d\} &= \{a, c\}, \\ RED_b^5\{a, c, d\} &= \{a, c\}, \{a, d\}, \{c, d\}, \\ RED_b^6\{a, c, d\} &= \{a\}, \{c\}, \end{aligned}$$

hence the following decision rules are valid

$$\begin{aligned} a_0 &\rightarrow b_1, \\ a_1c_1 &\rightarrow b_0, \\ c_2 &\rightarrow b_1, \\ c_0 &\rightarrow b_1, \\ a_1d_0 &\rightarrow b_0, \\ c_1d_0 &\rightarrow b_0. \end{aligned}$$

For the attribute *c* we have

$$\begin{aligned} RED_c^2\{a, b, d\} &= \{b\}, \\ RED_c^3\{a, b, d\} &= \{a, b\}, \\ RED_c^4\{a, b, d\} &= \{a, b\}, \{a, d\}, \\ RED_c^5\{a, b, d\} &= \{b\}, \{a, d\}, \end{aligned}$$

which yields decision rules

$$\begin{aligned} b_0 &\rightarrow c_1, \\ a_1b_1 &\rightarrow c_2, \\ a_0d_0 &\rightarrow c_0, \\ b_1d_0 &\rightarrow c_0, \\ a_1d_0 &\rightarrow c_1. \end{aligned}$$

For the attribute *d* we get

$$\begin{aligned} RED_d^1\{a, b, c\} &= \{a, c\}, \{b, c\}, \\ RED_d^3\{a, b, c\} &= \{c\}, \{a, b\}, \\ RED_d^4\{a, b, c\} &= \{c\}, \\ RED_d^6\{a, b, c\} &= \{c\}, \end{aligned}$$

which gives

$$\begin{aligned} a_0c_1 &\rightarrow d_1, \\ b_1c_1 &\rightarrow d_1, \\ c_2 &\rightarrow d_1, \\ c_0 &\rightarrow d_0. \end{aligned}$$

The above decision rules can be presented in a more compact form

$$\begin{aligned}
 b_1c_1 \vee b_1d_0 \vee c_0 &\rightarrow a_0, \\
 b_0 \vee c_1d_0 &\rightarrow a_1, \\
 a_1c_1 \vee a_1d_0 \vee c_1d_0 &\rightarrow b_0, \\
 a_0 \vee c_0 \vee c_2 &\rightarrow b_1, \\
 a_0d_0 \vee b_1d_0 &\rightarrow c_0, \\
 b_0 \vee a_1d_0 &\rightarrow c_1, \\
 a_1b_1 &\rightarrow c_2, \\
 c_0 &\rightarrow d_0, \\
 a_0c_1 \vee b_1c_1 \vee c_2 &\rightarrow d_1.
 \end{aligned}$$

Relations between all decision rules can be depicted as a *connection graph*. Vertices of the graph represent attribute-value pairs (drawn in a similar way as multistate devices, e.g., flip-flops, in the case of binary circuits), whereas branches of the graph show connections (implications) between corresponding attribute-value pairs. The connection graph for the above set of decision rules is shown Fig. 1. Thus Table 6 can be seen as a concise denotation of all minimal decision rules by the table.

Table 6 considered in this section can be also understood not as a result of observations but, as a specification of requirements for a special discrete systems behavior. In this case Fig. 1 is to be understood not as a visual aid of "cause-effect" relations occurring in the observed data, but as a schemata of an algorithm specified by the table.

## Acknowledgments

This work was supported by grant No. 8 S503 021 06 from State Committee for Scientific Research.

## References

- [1] Bazan, J., Skowron, A., and Synak, P. (1995). Discovery of decision rules from experimental data. in: Lin, T.Y. and Wildberger, A.M. (eds.), *The Third International Workshop on Rough Sets and Soft Computing Proceedings (RSSC'94)*, San Jose State University, San Jose, California, USA, pp.276-279.
- [2] Beaubouef, T., Petry, F.E., and Buckles, B.P. (1995). Extension of the relational Database and its algebra with rough set techniques. *Computational Intelligence: An International Journal*, **11**, 233-245.
- [3] Czyżewski, A., and Kaczmarek, A. (1995). Speaker-independent recognition of isolated words using rough sets. in: Wang, P.P. (ed.), *Second Annual Joint Conference on Information Sciences PROCEEDINGS*, Wrightsville Beach, North Carolina, USA, pp.397-400.
- [4] Golan, R., and Edwards, D. (1993). Temporal rules discovery using datalogic/R+ with stock market data. in: Ziarko, Z. (ed.), *Rough Sets, Fuzzy Sets and Knowledge Discovery. Proceedings of the International Workshop on Rough Sets and Knowledge Discovery (RSKD'93)*, Banff, Alberta, Canada, Springer-Verlag, Berlin, pp.74-81.
- [5] Grzymala-Busse, J.W. (1992). LERS-a system for learning from examples based on rough sets. in: Slowiński, R. (ed.), *Intelligent Decision Support. Handbook of Applications and Advances of the Rough Set Theory*, Kluwer Academic Publishers, Dordrecht, pp.3-18.
- [6] Grzymala-Busse, and Woolerly, L. (1994). Improving prediction of preterm birth using a new classification scheme and rule induction. *Proc. of the 18-th Annual Symposium on Computer Applications in Medical Care (SCAMC)*, Washington D.C. pp.730-734.
- [7] Gunn, J.D., and Grzymala-Busse, J.W. (1994). Global temperature stability by rule induction: an interdisciplinary bridge. *Human Ecology*, **22**, 59-81.
- [8] Jackson, A.G., LeClair, S.R., Ohmer, M.C., Ziarko, W., and Al-Kamhwi, H. Rough sets applied to material data. *Acta Metallurgica et Materialia*, (to appear).
- [9] Jelonek, J., Krawiec, K., Slowiński, R., and Szymas, J. (1994). Rough set reduction of features for picture-based reasoning. in: Lin, T.Y. (ed.), *The Third International Workshop on Rough Sets and Soft Computing Proceedings (RSSC'94)*, San Jose State University, San Jose, California, USA, pp.418-425.
- [10] Krysiński, J. (1995). Application of the rough sets theory to the analysis of structure -activity-relationships of antimicrobial pyridinium compounds. *Die Pharmazie*, **50**, 593-597.
- [11] Lin, T.Y., and Wildberger A.M. (eds.). (1995). *The Third International Workshop on Rough Sets and Soft Computing Proceedings (RSSC'94)*, San Jose State University, San Jose, California, USA.
- [12] Montalbano, M. (ed.). (1974). *Decision Tables*, Science Research Associates, INC., Chicago, Palo Alto, Toronto, Henley-on-Thames, Sydney, Paris.
- [13] Munakata, T. (1995). Rough control: Basic ideas and applications. in: Wang, P.P. (ed.), *Second Annual Joint Conference on Information*



Sciences PROCEEDINGS, Wrightsville Beach, North Carolina, USA, pp.340-343.

- [14] Pawlak Z. (1982). Rough sets. *International Journal of Computer and Information Sciences*, **11**, 341-356.
- [15] Pawlak Z. (1991). *Rough Sets - Theoretical Aspects of Reasoning about Data*. Kluwer Academic Publishers, Dordrecht, Boston, London.
- [16] Pawlak Z., Grzymala-Busse J. W., Slowiński R., and Ziarko, W. (1995). Rough sets. *Communication of the ACM*, **38**, 88-95.
- [17] Plonka, L., and Mrózek, A. (1995). Rule-based stabilization of the inverted pendulum. *Computational Intelligence: An International Journal*, **11**, 348-356.
- [18] Skowron, A. (1995). Extracting laws from decision tables. *Computational Intelligence*, **11**, 371-388.
- [19] Skowron, A., and Suraj, Z. (1993). A rough set approach to the real-time state identification. *EATCS Bulletin of the European Association for Theoretical Computer Science*, **50**, 264-275.
- [20] Slowiński, R. (ed.). (1992). *Intelligent Decision Support. Handbook of Applications and Advances of the Rough Set Theory*, Kluwer Academic Publishers, Dordrecht.
- [21] Slowiński, R. (1995). Rough Set Approach to Decision Analysis. *AI Expert*, **10**, 18-25.
- [22] Slowiński, R., and Zopounidis, C. (1994). Rough set sorting of firms according to bankruptcy risk. in: Paruccini, M. (ed.), *Applying Multiple Criteria Aid for Decision to Environmental Management*, Kluwer, Dordrecht, Netherlands, pp.339-357.
- [23] Slowiński, K., and Sharif, E.S. (1993). Rough sets approach to analysis of data: of diagnostic peritoneal lavage applied for multiple injuries patients. in: Ziarko, W. (ed.), *Rough Sets, Fuzzy Sets and Knowledge Discovery. Proceedings of the International Workshop on Rough Sets and Knowledge Discovery (RSKD'93)*, Banff, Alberta, Canada, Springer-Verlag, Berlin, pp.420-425.
- [24] Szladow, A. (1993). Datalogic/R: Mining the knowledge in databases. *PC AI*, **7**, 40-41.
- [25] Szladow, A., and Ziarko W. (1993). Rough sets: Working with imperfect data. *AI Expert*, **7**, 36-41.
- [26] Tanaka, H., Ishibuchi, H., and Shigenaga, T. (1992). Fuzzy inference system based on rough sets and its application to medical diagnostic. in: Slowiński, R. (ed.), *Intelligent Decision Support. Handbook of Applications and Advances of the Rough Set Theory*, Kluwer Academic Publishers, Dordrecht, pp.111-117.
- [27] Teghem, J., and Charlet J.-M. (1992). Use of 'rough sets' method to draw premonitory factors for earthquakes by emphasizing gas geochemistry: The case of a low seismic activity context, in Belgium. in: Slowiński, R. (ed.), *Intelligent Decision Support. Handbook of Applications and Advances of the Rough Set Theory*, Kluwer Academic Publishers, Dordrecht, pp.165-180.
- [28] Tsumoto, S., and Tanaka, H. (1995). PRIMEROSE: Probabilistic rule induction method based on rough set and resampling methods. *Computational Intelligence: An International Journal*, **11**, 389-405.
- [29] Tsumoto, S., and Tanaka, H. (1995). Induction of expert system rules from databases based pm rough set theory and resampling methods. in: Wang P.P. (ed.), *Second Annual Joint Conference on Information Sciences PROCEEDINGS*, Wrightsville Beach, North Carolina, USA.
- [30] Wang, P.P. (ed.). (1995). *Second Annual Joint Conference on Information Sciences PROCEEDINGS*, Wrightsville Beach, North Carolina, USA.
- [31] Woolery, L.K. and Grzymala-Busse, J. (1994). Machine learning for an expert system to predict preterm birth risk. *Journal of the American Medical Informatics Association*, **1**, 439-446.
- [32] Ziarko, W. (1991). The discovery, analysis and representation of data dependencies in databases. in: Piatetsky-Shapiro, G. and Frawley, W. J. (eds.), *Knowledge Discovery in Databases*, AAAI Press/MIT Press, pp.177-195.
- [33] Ziarko, W. (ed.). (1993). *Rough Sets, Fuzzy Sets and Knowledge Discovery. Proceedings of the International Workshop on Rough Sets and Knowledge Discovery (RSKD'93)*, Banff, Alberta, Canada, Springer-Verlag, Berlin.
- [34] Ziarko, W., Golan, R., and Edwards, D. (1993). An application of DATALOGIC/R knowledge discovery tool to identify strong predictive rules in stock market data. in: *Proc. AAAI Workshop on Knowledge Discovery in Databases*, Washington, DC, pp.89-101

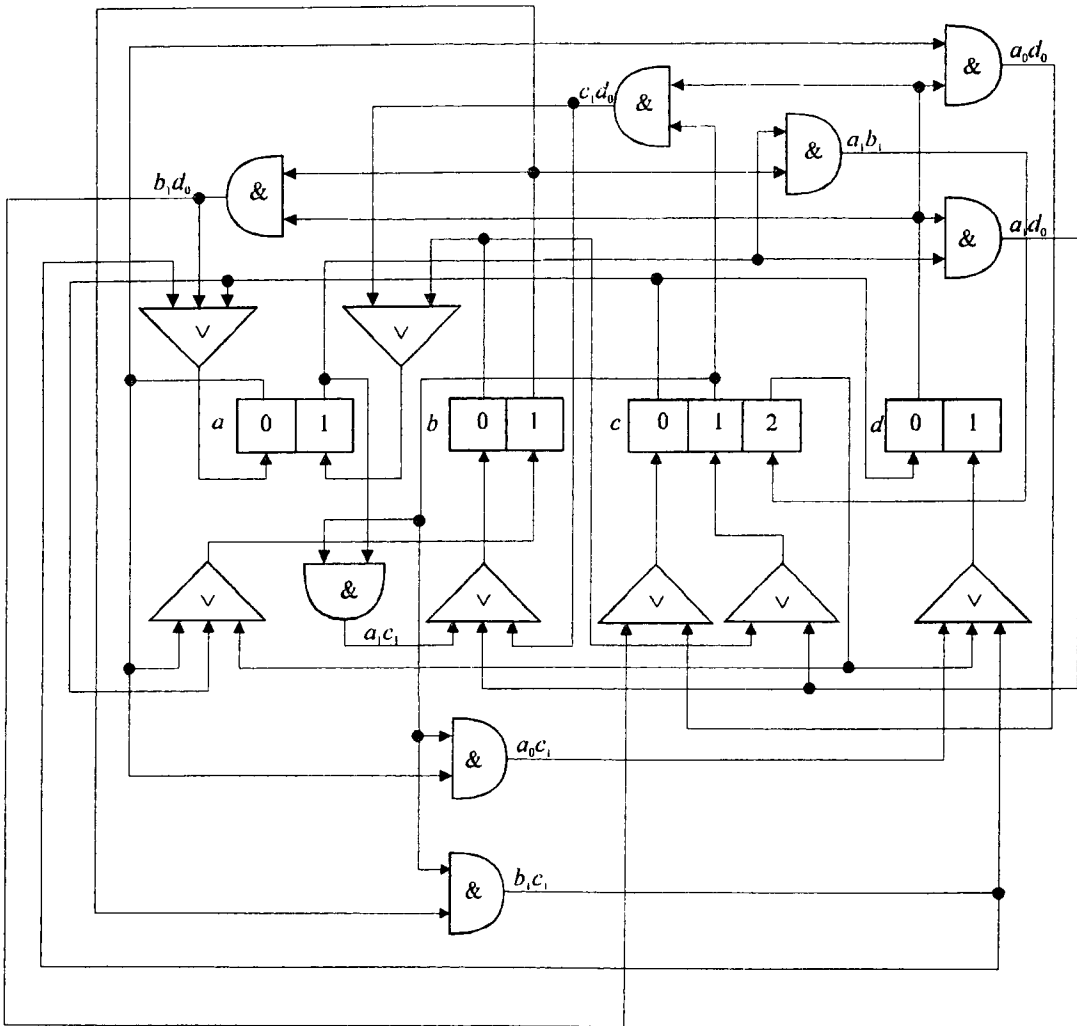

Figure 1: Connection Graph